

# EAGLE 9C Installation & Operation Manual

9,000 Lbs. Capacity Two-Post Lift | EAG -9C

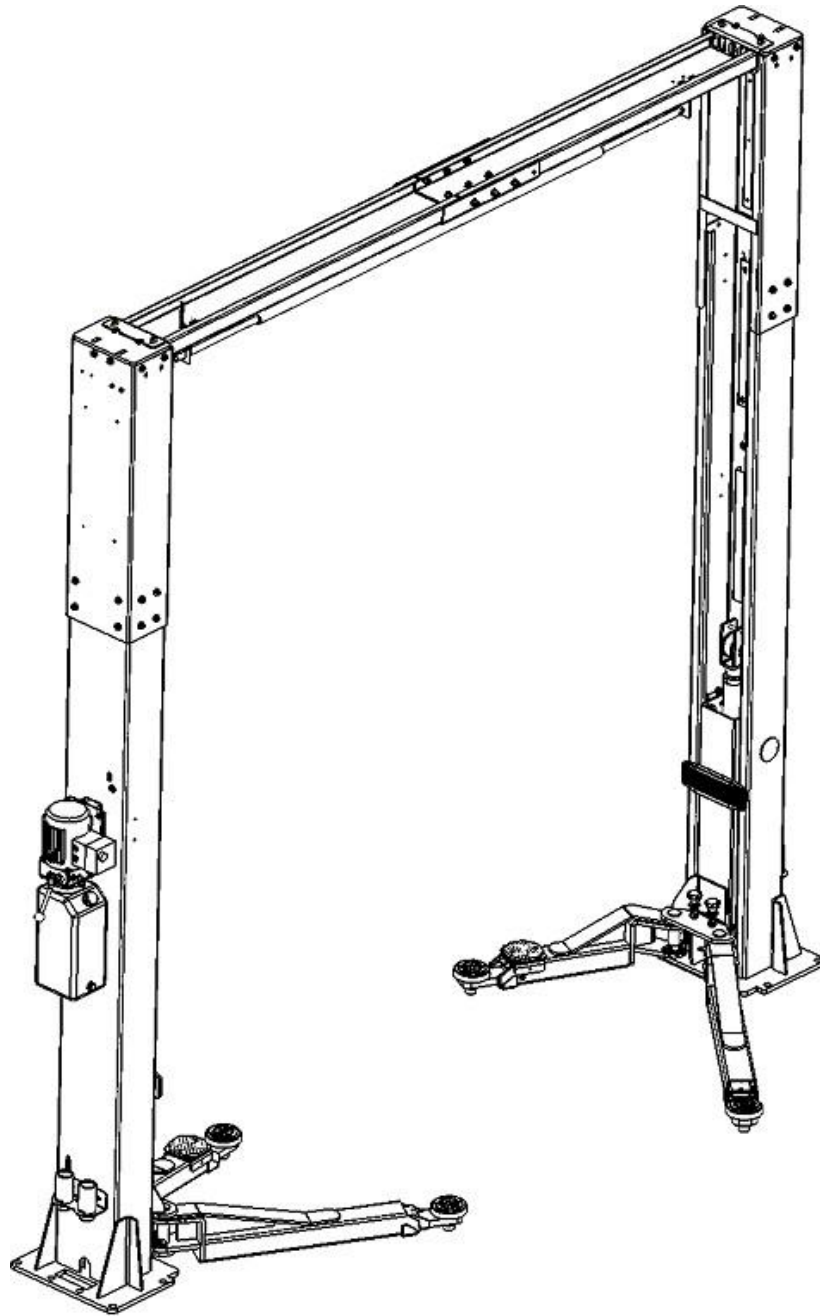

**READ THIS MANUAL BEFORE INSTALLING OR OPERATING THE LIFT.  
INSPECT THE LIFT UPON DELIVERY. NOTE ANY DAMAGE ON DELIVERY RECEIPT.**

## CONTENTS

Product Description.....	3
Shipping and Damage Claims .....	3
Introduction .....	4
Unpacking.....	5
Important Safety Instructions .....	6
Intended Use .....	7
Safety Instructions for Commissioning.....	7
Safety Features .....	7
Important Concrete and Anchoring Information.....	8
Anchoring Tips .....	8
Installation Instructions.....	8-10
Specifications .....	10
Installation Figures .....	11-15
Wiring Diagram.....	16
Operation.....	17
Defects/Malfunctions .....	17
Arm Restraint.....	18
Preparations.....	18
Raising the Lift.....	19
Vehicle in Raised Position.....	19
Lowering the Lift.....	19
Maintenance.....	20-22
Troubleshooting .....	23
Eagle Equipment Lift Warranty .....	24

# PLEASE READ THE ENTIRE MANUAL BEFORE INSTALLATION AND OPERATION OF LIFT.

## PRODUCT DESCRIPTION

The EAG-9C is a 2-post, chain driven lift, **9,000 lbs. capacity.**

**Please read the safety procedures and operation instructions in this manual before operating the lift. Proper installation is very important. Keep this operation manual near the machine at all times. Make sure ALL USERS read and fully understand this manual.** To minimize the chance of making an error in installation, please read this manual carefully before beginning installation. Check with the building owner and/or architect's building plans when applicable. The lift should be installed on a relatively level floor with 4" (101mm), 3,000 PSI (207bar) concrete that has sufficiently cured.

This is a vehicle lift installation/operation manual and no attempt is made or implied herein to instruct the user in lifting methods particular to an individual application. Rather, the contents of this manual are intended as a basis for operation and maintenance of the unit as it stands alone or as it is intended and anticipated to be used in conjunction with other equipment.

Proper application of the equipment described herein is limited to the parameters detailed in the specifications and the uses set forth in the descriptive passages. Any other proposed application of this equipment should be documented and submitted in writing to Eagle Equipment for review. The user assumes full responsibility for any equipment damage, personal injury, or alteration of the equipment described in this manual or any subsequent damages.

## **INSPECT YOUR LIFT UPON DELIVERY. NOTE ANY DAMAGE ON DELIVERY RECEIPT.**

## SHIPPING AND DAMAGE CLAIMS

**All shipments must be inspected immediately upon receipt.** For your protection, any external damage must be noted on the bill of lading at the time of delivery in order to qualify for a claim against the freight carrier.

**Concealed damage must be reported to the freight company within three (3) days of delivery.** It is the customer's responsibility to file for damage claims against the freight company. Eagle Equipment is not responsible for loss or damages caused by shipping.

Shortages or missing parts must be reported to Eagle Equipment Customer Service (1-800-336-2776) within three (3) days of delivery.

## INTRODUCTION

Thank you for your purchase.

Your lift is the result of decades of research, testing, and development; and represents the most advanced technology on the market.

The care with which you maintain and operate your lift will directly affect its overall performance and longevity.

BE SAFE.

Your lift was designed and built with safety in mind. However, safety relies on proper training and thoughtful use on the part of the operator. DO NOT operate or repair this equipment without reading this manual and the important safety instructions shown inside.

Keep these instructions accessible, and make sure that ALL USERS read this manual.

**PLEASE READ THIS MANUAL IN ITS ENTIRETY BEFORE  
INSTALLING OR OPERATING THIS LIFT.**

**RECORD THE MODEL NUMBER AND THE SERIAL NUMBER**

This information is located on the main post of your lift.

Model Number: \_\_\_\_\_

Serial Number: \_\_\_\_\_

Manufacturing Date: \_\_\_\_\_

**THIS INFORMATION WILL BE REQUIRED  
SHOULD YOU EVER NEED TO CALL IN FOR  
PARTS OR TECHNICAL ASSISTANCE**

For parts assistance, please call: 1-800-336-2776

## **WARNING:**

**Failure to follow the unpacking and assembly directions may cause personal injury and/or impair the operation of this machine.**

**PLEASE READ THOROUGHLY.**

### **UNPACKING**

1. Your lift comes packaged as a single unit. A fork-lift, floor-jack or other heavy-lifting equipment may be necessary to separate the components. Exercise caution when disassembling the packaged lift, as shifting may have occurred during shipping.
2. Carefully remove the shipping bands and brackets from the lift. Check for any obvious shipping damage. Remember to report any shipping damage to the carrier and make a notation on the delivery receipt. Save all bolts, nuts and washers securing the shipping brackets, as these may be used in the assembly of the lift.
3. The unit is composed of several main components.
4. An accessory box is included with the lift and contains smaller components.
5. Unstrap and remove the power unit box from the packaged lift. Literature such as the installation manual, warranty card, and serial number plate is included inside this box. inspect the power unit and note any possible shipping damage on the shipping bill.



**Shipments must be inspected immediately upon receipt.**

**External damage must be noted on the Bill of Lading.**

**Concealed damages must be reported to the freight company within three days of delivery.**

**Shortages must be reported to Eagle Equipment within three days of delivery:**

**1-800-336-2776.**

## IMPORTANT SAFETY INSTRUCTIONS

### READ THESE SAFETY INSTRUCTIONS THOROUGHLY

1. Read and understand all operation and safety warning procedures before operating the lift.
2. Keep hands and feet clear. Remove hands and feet from any moving parts. Keep feet clear of lift when lowering. Avoid pinch points.
3. Keep work area clean. Cluttered work areas invite injuries. Consider work area environment. Do not expose equipment to rain. Do not use in damp or wet locations. Keep area well lit.
4. Only trained personnel should operate this lift. All non-trained personnel should be kept away from the work area. Never let non-trained personnel come in contact with or operate the lift.
5. Use the lift correctly. Never use lifting adapters other than those provided by the manufacturer, in any manner other than intended. Only use the vehicle manufacturer's recommended lift points.
6. Do not override self-closing manuals. Do not overload the lift. Load capacity is indicated on lift nameplate.
7. Remain clear of lift when raising or lowering vehicle. Clear area if vehicle is in danger of falling.
8. After positioning the vehicle, apply the parking break. Make sure the vehicle doors are closed during raising and lowering cycles. Do not allow anyone on the lift or inside the raised vehicle.
9. Always ensure that the safeties are engaged before any attempt is made to work on or near vehicle. After raising the vehicle briefly, stop and check the pad adapters for secure contact. Always lift vehicle using all four adapters.
10. Use caution when removing or installing heavy components (center-of-gravity displacement).
11. Dress properly. Non-skid, steel-toe foot-wear and safety glasses is recommended when operating lift.
12. Guard against electric shock. This lift must be grounded while in use to protect the operator from electric shock. Never connect the ground wire to a live terminal. This is for ground only.
13. **DANGER:** The power unit used on this lift contains high voltage. Disconnect power at the receptacle before performing any electrical repairs. Secure plug so that it cannot be accidentally plugged in during service.
14. **WARNING:** Risk of explosion. This equipment has internal arcing or sparking parts which should not be exposed to flammable vapors. This machine should not be located in a recessed area or below floor level.
15. Maintain with care. Keep lift clean for better and safer performance. Follow manual for proper lubrication and maintenance instructions. Keep control handles and/or buttons dry, clean and free from grease and oil. Protect all parts of the electrical equipment from humidity and moisture.
16. Carefully inspect the lift on a regular basis. Perform maintenance according to the maintenance schedule.
17. Check for damaged parts. Check alignment of moving parts, breakage of parts or any condition that may affect its operation. Do not use lift if any component is broken or damaged.
18. Never remove safety related components from the lift. Do not use the lift if safety related components are damaged or missing.
19. Stay alert. Watch what you are doing. Use common sense. Be aware.

### Working temperatures:

1. Ambient temperature: 41-104 degrees Fahrenheit
2. Humidity: 30-95%
3. Transportation/storage temperature: 77-131 degrees Fahrenheit, not exceeding 24 hours at up to 158 degrees Fahrenheit
4. Installation altitude max: 3280 feet (1000m)

## INTENDED USE

This lift is designed for the safe lifting of automotive vehicles. Observe the rated load capacity and load distribution of the lift.

Model	Capacity	Load Distribution Front:Rear	
EAG-9C	9000 lbs.	MINIMUM 2:3	MAXIMUM 3:2

In principle, the lift is designed for entry from both directions. However, we recommend using the short support arms for engaging the engine side of the vehicle.

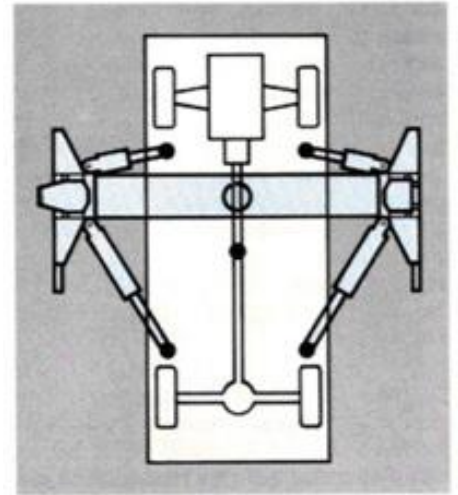

## SAFETY INSTRUCTIONS FOR COMMISSIONING

The lift may be installed and commissioned by authorized service personnel only. The standard lift version may not be installed and commissioned in the vicinity of explosives or flammable liquids, outdoors or in moist rooms (e.g. a car wash).

## SAFETY FEATURES

- **Dead Man's Type Control:** The operator is required to hold the controls in the engaged position to raise or lower the lift.
- **Equalizing System:** The lift is provided with equalizing cables to ensure level movement of both carriages.
- **Collision Prevention Switch:** An electric-operated limit switch prevents collisions between the vehicle roof and ceiling.
- **Automatic Arm Restraint:** Once the lift is raised, the arm restraints are locked automatically to avoid any swivel under load.
- **Pipe Break Valve:** The hydraulic cylinders are equipped with pipe break valves. They respond in case of rapid pressure drop (line break) to prevent sudden lowering movements.
- **Pressure Relief Valve:** A pressure relief valve is used to limit the hydraulic working pressure to a maximum of 150bar.

## IMPORTANT CONCRETE AND ANCHORING INFORMATION

1. Concrete should have compression strength of at least 3,000 PSI (207bar) and a minimum thickness of 4" (101 mm) in order to achieve a minimum anchor embedment of 3.2" (82mm). When using the standard supplied nineteen (19) 5.5" (140mm) long anchors, if the top of the anchor exceeds 57 above the floor grade, you DO NOT have enough embedment. Please refer Fig 3.
2. Before drilling .75" (19mm) diameter holes in concrete floor, use the holes in the column base plate as a guide. Make sure the hole distance from the edge is not less than 7.8" (200mm). Hole to hole spacing should not be less than 7.87" (165mm) in any direction. Concrete thickness or hole depth should be a minimum of 4.5" (114mm).
3. **CAUTION.** DO NOT install on asphalt or other similar unstable surface. Columns are supported only by anchoring in the floor.
4. Shim each column base until each column is plumb. If one column has to be elevated to match the plane of the other column, full size base shim plates should be used (Reference Shim Kit). Torque anchors to 203N-m/s. Shim thickness MUST NOT exceed .5" (13mm) when using the 5.5" (140mm) long anchors provided with the lift. Adjust the column extensions plumb.
5. If anchors do not tighten to 203N-m/s. Installation torque, replace concrete under each column base with a 48" (1219mm) x 48" (1219mm) x 6" (152mm) thick 3,000 PSI (207bar) minimum concrete pad keyed under and flush with the top of existing floor. Let concrete cure before installing lifts and anchors.

## ANCHORING TIPS

1. Use a concrete hammer drill with a carbide tip, solid drill bit the same diameter as the anchor .75" (19mm). Do not use excessively worn bits or bits which have been incorrectly sharpened.
2. Keep the drill in a perpendicular line while drilling.
3. Let the drill do the work. Do not apply excessive pressure. Lift the drill up and down occasionally to remove residue to reduce binding.
4. Drill the hole to depth equal to the length of anchor.
5. For better holding power blow dust from the hole.
6. Place a flat washer and hex nut over threaded end of anchor, leaving approximately .5" of thread exposed carefully tap anchor. Do not damage threads. Tap anchor into the concrete until nut and three turns on average concrete (28-day cure). If the concrete is very hard only one or two turns may be required.

## INSTALLATION INSTRUCTIONS

**PLEASE READ INSTRUCTIONS BEFORE OPERATING THE LIFT. Please refer to Fig 2.**

STEP 1: After unloading the lift, place it near the intended installation location.

STEP 2: Remove the shipping bands and packing materials from the unit.

STEP 3: Remove the packing brackets and bolts holding the two columns together (do not discard bolts, they are used in the assembly of the lift)

## INSTALLATION INSTRUCTIONS

STEP 4: Once the power unit column location is decided, ensure that the proper lift placement is observed from walls and obstacles. Also check the ceiling height for clearance in this location. Note the power unit column can be located on either side. It is helpful to try and locate the power side with the passenger side of the vehicle when loaded on the lift to save steps during operation.

STEP 5: Position the columns facing each other 117" (2940mm) outside the base plates.

STEP 6: Using a .75" (19mm) concrete drill, drill the anchor holes in the main side column, installing anchors as you go. Use a block of wood or rubber mallet to drive anchor bolts in. Drill to a minimum depth of 4" (101 mm) to ensure maximum holding power. Drilling through concrete (recommended) will allow the anchor to be driven through the bottom if the threads are damaged.

STEP 7: Using a level, check column for side-to-side plumb and front-to-back plumb. Use .75" (19mm) washers or shim stock, placing shims as close as possible to the hole locations. This will prevent bending the column bottom plates. Tighten .75" (19mm) anchor bolts to 143 lbs (65Kgs).

STEP 8: Using a measuring tape, measure from the back corner of the base on main side column to the opposite back corner of the offside column to insure legs are square. Using the dimensions, install overhead beam to top of columns BEFORE drilling anchors for offside column to insure column level.

STEP 9: After the overhead beam is assembled, drill and anchor offside column as described in steps 4 and 5.

STEP 10: Installing the equalizing cables: refer to Fig 4 and for general cable arrangement for the lift. Set carriages on the second safety latch engagement. Be sure each carriage is at the same height by measuring from the top of the base to the bottom of the carriage (double check the latches before working under the carriages). This dimension should be within .23" (6mm). Run first cable (Fig 4). Tighten nut on one cable stud so that the end of stud passes the nylon on the nut. Pull the other end of cable and run nut on it. Tighten both nuts. Repeat above for second cable.

STEP 11: Connecting the hydraulic hoses, as shown on Fig 5 for overhead type.

STEP 12: Mount the power unit on lift as Fig 5.

STEP 13: Install the swing arms on the carriages using the included 1.5" (38mm) diameter pins. Check for proper engagement of the arm lock- the rack on the lock should fully engage the gear on the arm.

STEP 14: Adjust the carriage cables tension. Adjust each cable to approximately .5" (13mm) side-to-side play. Check the latch releases to insure the carriage is still sitting on the appropriate latch.

STEP 15: Remove the vent plug from the power unit and fill the reservoir. Use AW-32/ISO-32 non-foaming, non-detergent hydraulic fluid (DO NOT USE ATF). Using unapproved fluid will void the warranty. The unit will hold twelve quarts of fluid.

STEP 16: Make the electrical hookup to the power unit. 220V Single Phase. It is recommended that a 220 Volt, 30 Amp twist lock plug be installed in the power line just ahead of the power unit. Size wire for 30-amp circuit.

**WARNING:** The wiring must comply with local code. Have a certified electrician make the electrical hook-up to the power unit. Protect each circuit with time delay fuse or circuit breaker 208v.230v single Phase. 60 Hz 30 Amps. Motor cannot run on 50 Hz without a physical change to motor.

## INSTALLATION INSTRUCTIONS

STEP 17: **Do not place any vehicle on the lift at this time.** Cycle the lift up and down several times to insure latches click together and all air is removed from the system. To lower the lift, latch releases must be manually released. Latches will automatically reset once the lift ascends approximately 17" (432mm) from base. If latches click out of sync, tighten the cable on the one that clicks first.

## SPECIFICATIONS

EAG-9C	
Style	Asymmetric
Lifting capacity	9,000 lb
Overall height	142"
Overall width (outside of base plates)	139.7"
Width (outside of columns)	130"
Inside columns	116"
Front arm min reach	28"
Front arm max reach	41.4"
Rear arm min reach	39"
Rear arm max reach	57.6"
Min pad height	4"
Height adapters	1.75" - 3.5"
Rise	68.5"
Lifting height max (pad only)	72"
Lifting height max (with adapters)	75"
Drive-through clearance	96"
Time to full rise (no load)	52 secs
Anchoring	M18
Concrete grade min.	C20/25(DIN 1045:2001-07)
Motor power	3HP (2.2KW)
Power supply	220V/380V,50Hz/60Hz
Sound pressure level	≤75dB(A)
Shipping weight	1580 lbs.
Shipping dimensions	115"L x 20"W x 28.5"H

INSTALLATION INSTRUCTION: FIGURE 1

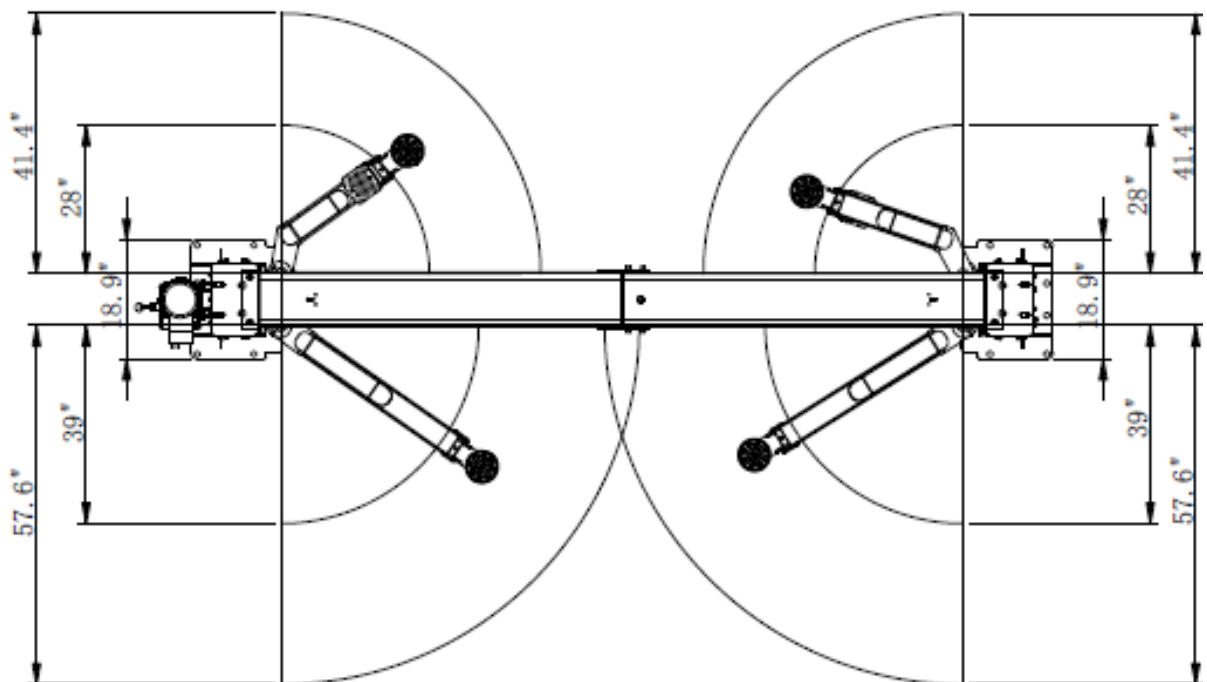
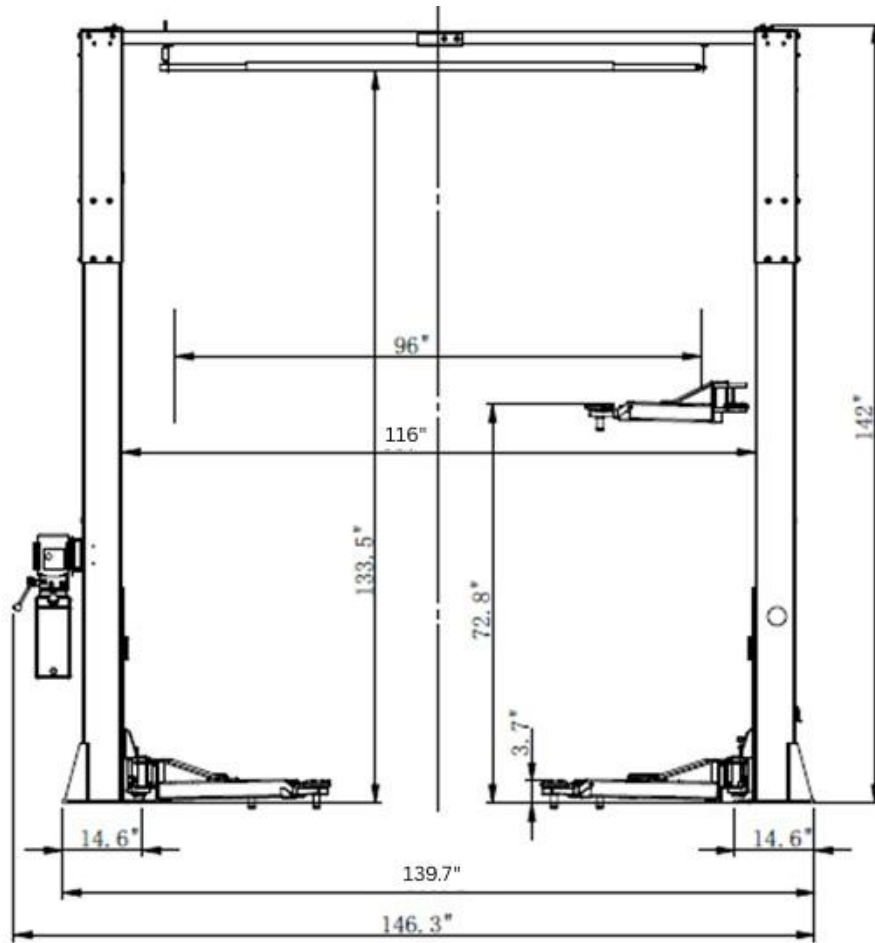

INSTALLATION INSTRUCTION: FIGURE 2

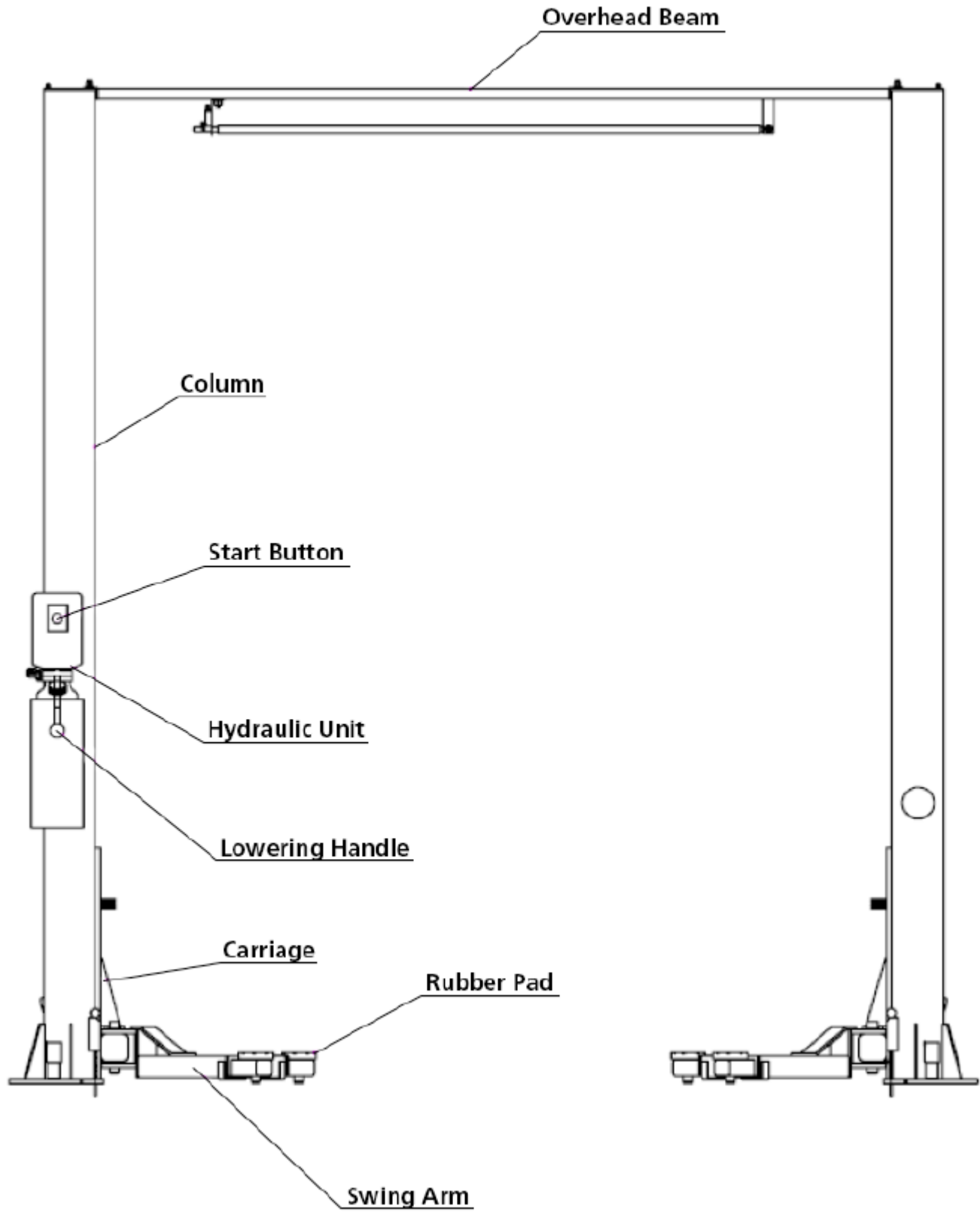

**INSTALLATION INSTRUCTION: FIGURE 3**

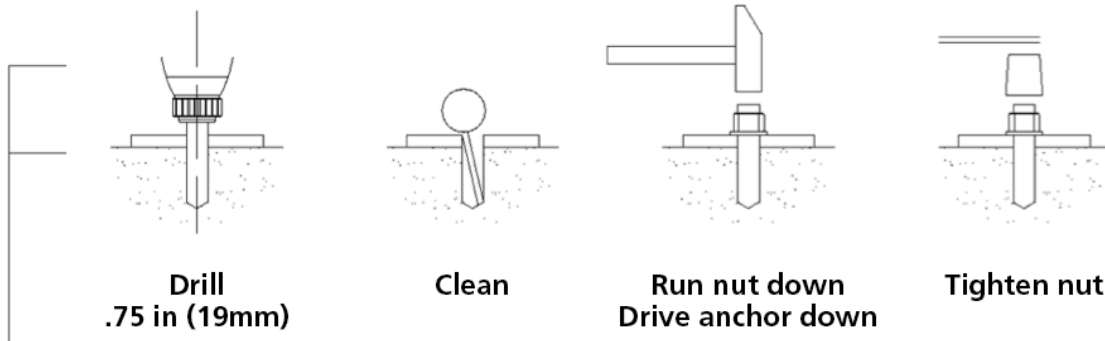
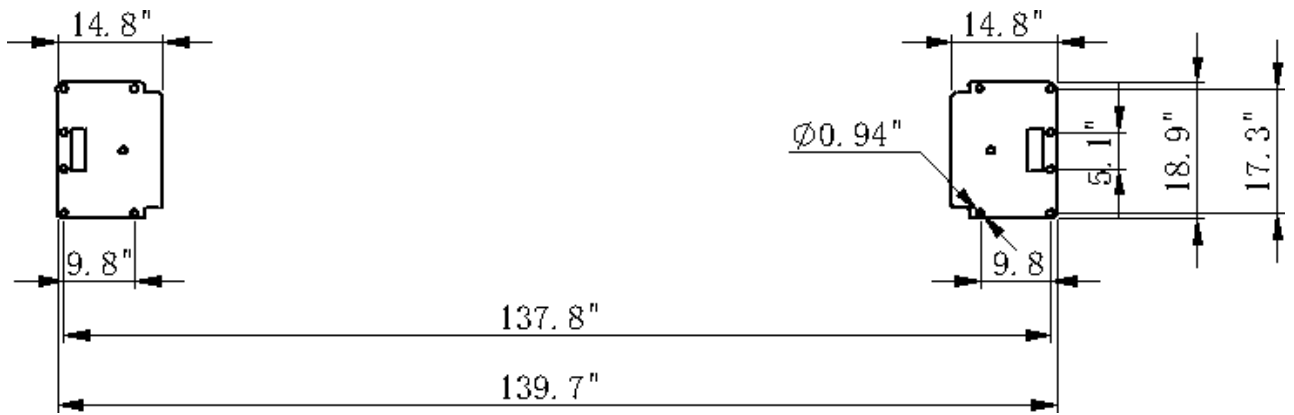
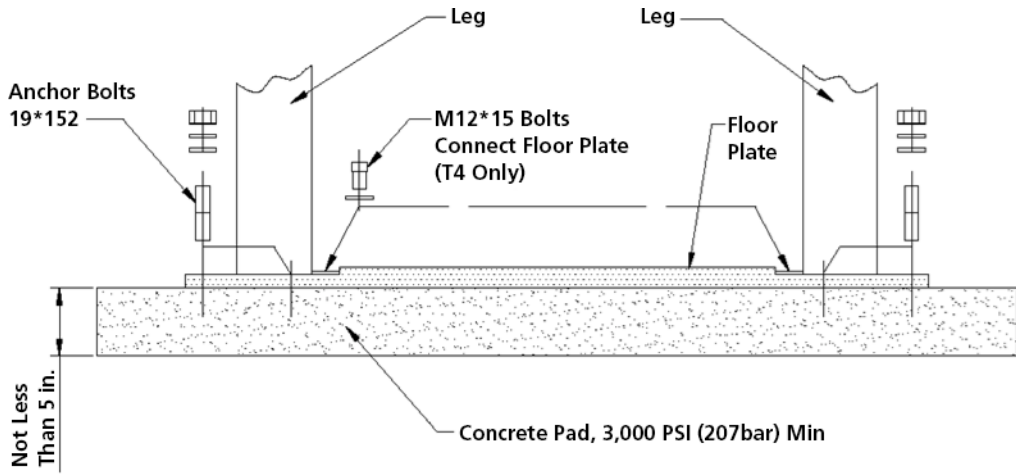

**INSTALLATION INSTRUCTION: FIGURE 4**

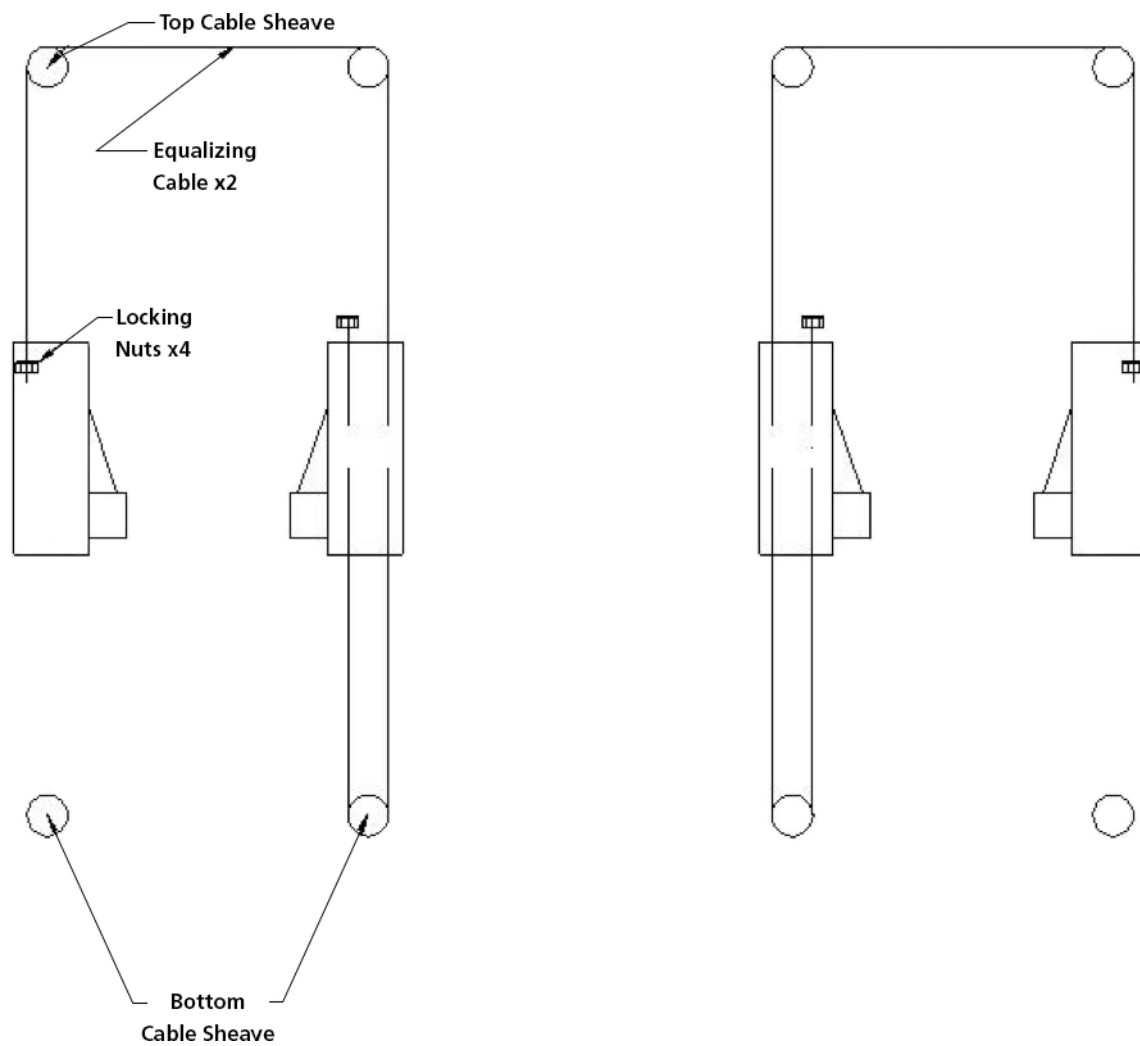

Note: Always try to keep two cables at the same tension.

INSTALLATION INSTRUCTION: FIGURE 5

Hydraulic Hoses

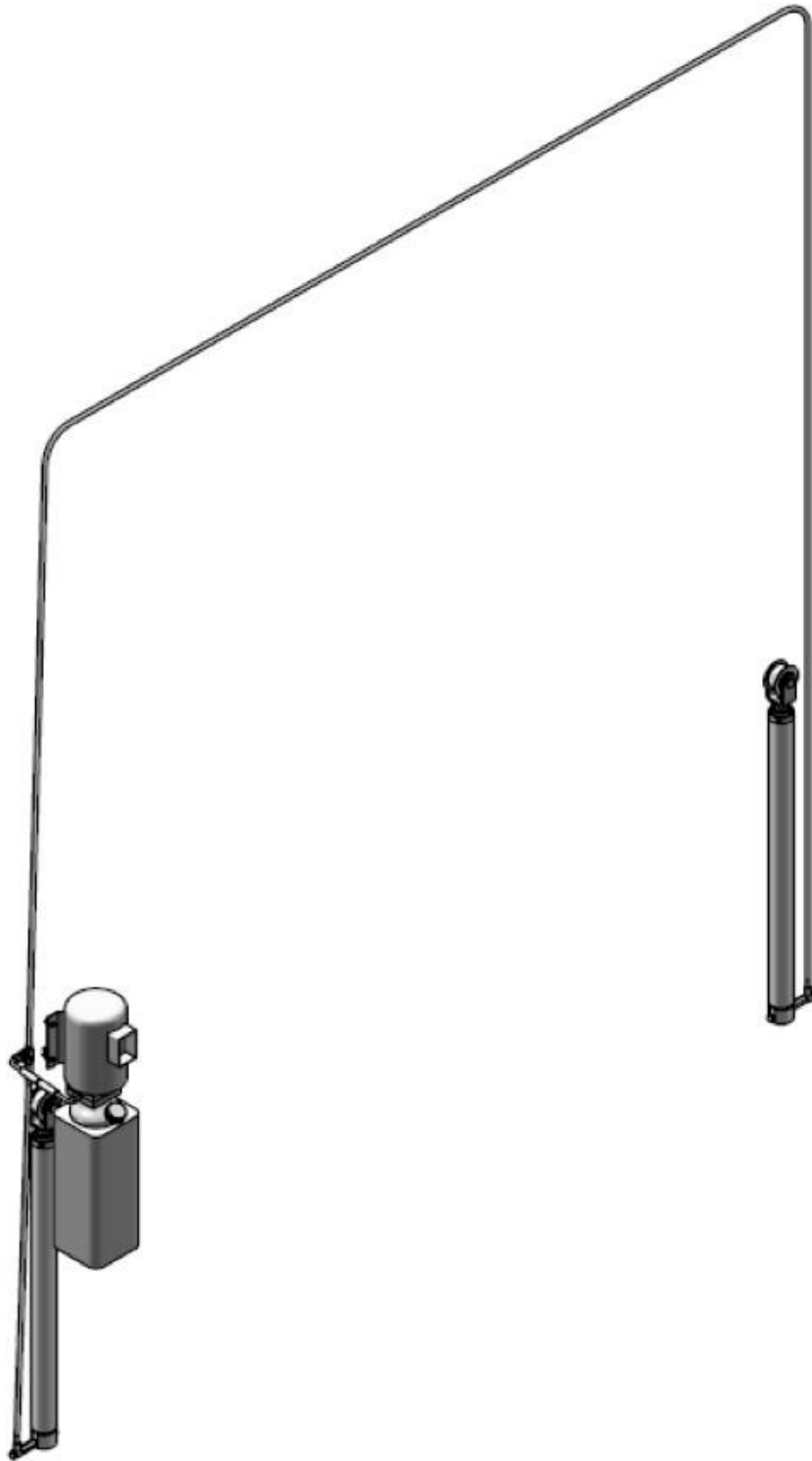

# WIRING DIAGRAM

220 Volts In

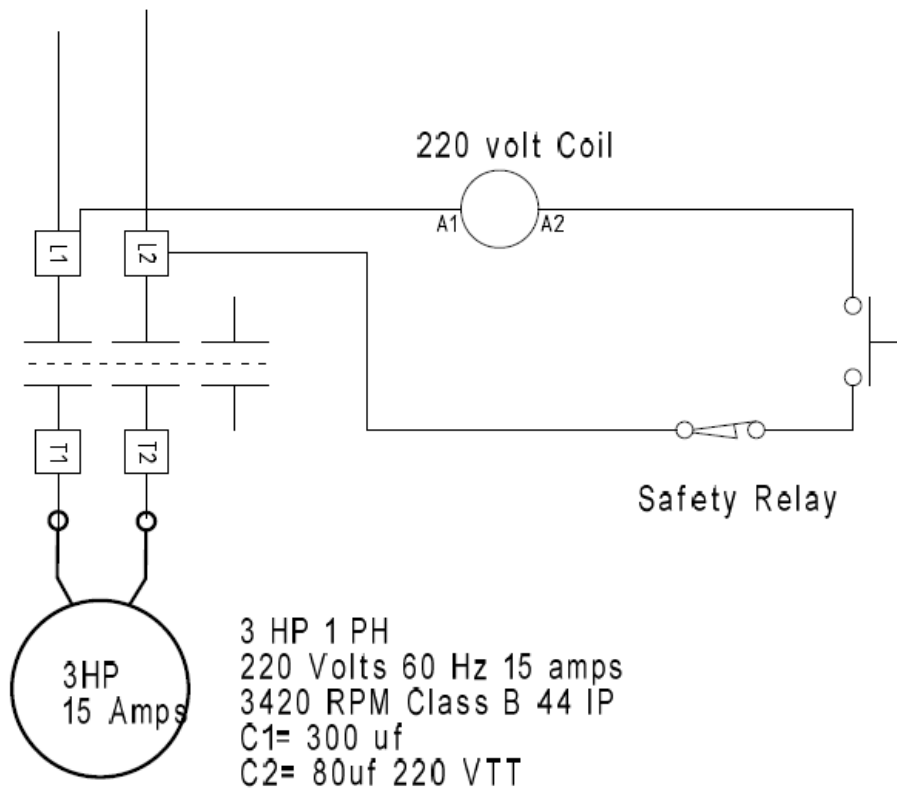

Momentary Normally Open  
Non Illuminated  
Green 22mm

## OPERATION

- Lift operation by authorized personnel over 18 years old only.
- Apply the parking brake after positioning the vehicle on the lift.
- Do not allow anyone to stay in lift area during raising and lowering cycles.
- Closely watch the vehicle and the lift during raising and lowering cycles.
- Observe the rated load capacity and load distribution.
- Do not allow anyone to climb on lift or stay inside vehicle.
- After raising the vehicle briefly, stop and check pads for secure contact.
- Once the disc adapters contact the lift points, check arm restraints for engagement.
- Make sure the vehicle doors are closed during raising and lowering cycles.

## DEFECTS/MALFUNCTIONS

**WARNING:** In case of defects or malfunctions such as jerky lift movements or deformation of the superstructure, you need to support or lower the lift immediately. Turn off the power switch. Contact qualified service personnel.

Once the UP button is actuated, the lift will move until the button is released or the limit stop is reached.

Once the lowering handle is actuated, the lift moves until the handle is released.



## ARM RESTRAINT

Once the pad disc adapters contact the lift points, check arm restraints for engagement. If necessary, slightly move the arms until the gear segments mesh. Never unlatch the arm restraints when the lift is under load.

Each support arm is provided with an automatic arm restraint which unlatches automatically when the lift is in bottom position.

When the carriages are in a raised position, the arm restraint can be disengaged by pulling the release pin.

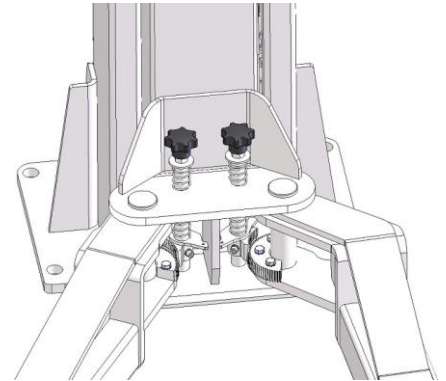

## PREPARATIONS

1. Fully lower the lift and swing the arms to full drive-through position
2. Slowly position the vehicle midway between columns. Apply the parking break.
3. Swing and telescope arms as required to position the adapters under the vehicle manufacturer's recommended lift points.
4. Turn the disc adapters so that they evenly contact all four lift points.
5. Leave vehicle and remain clear of the lift.

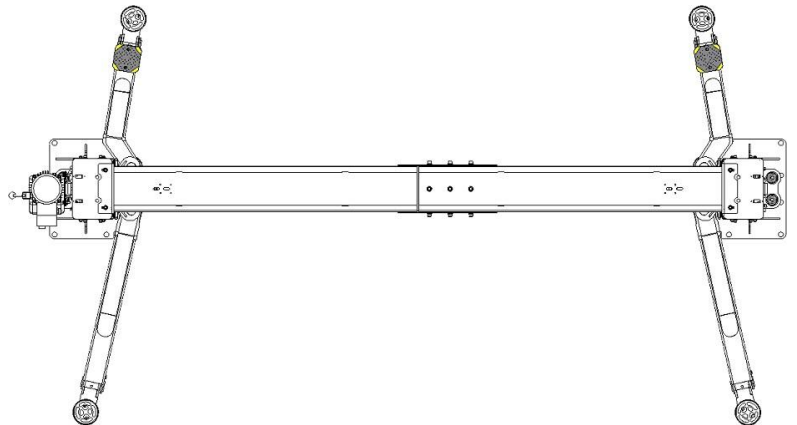

**Always lift the vehicle using all four pad disc adapters.**

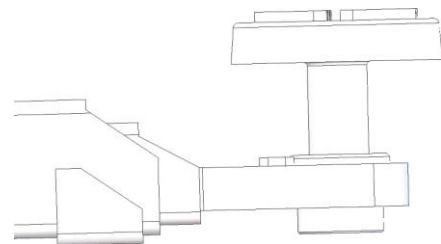

## RAISING THE LIFT

**During raising and lowering cycles: closely watch the vehicle and the lift, do not allow anyone to stay in the lift area. Make sure the vehicle doors are closed.**

**Once the pad disc adapters contact the lift points, check the arm restraints for engagement.**

**After raising the vehicle briefly, stop and check the adapters for secure contact.**

1. Press and hold the UP button until the lift reaches desired height.  
Lift stops once button is released or the limit stop release is reached.
2. Lower vehicle on the locks.

## VEHICLE IN RAISED POSITION

- Observe all accident prevention regulations.
- Do not allow unauthorized persons to stay under the raised vehicle.
- Avoid rocking of vehicle.
- Keep lift free of tools, parts, etc.
- Fasten the vehicle to the support arms using lashing straps when removing or installing heavy components.
- Set on Locks

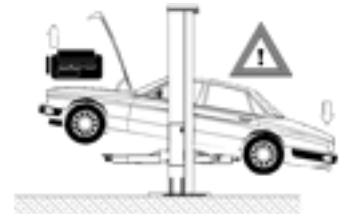

After the lift reaches its desired height, pull down the lowering handle until the lift rests on safety latch. This allows the lift to be securely fixed when the vehicle is in a raised position.

## LOWERING THE LIFT

**During raising and lowering cycles: closely watch the vehicle and the lift, do not allow anyone to stay in the lift area and make sure the vehicle doors are closed.**

1. Remove tools, stands or other objects from the lift bay.
2. If the safety latch is in the engaged position, briefly raise the lift slightly to allow adequate clearance for the locks to clear.
3. Pull the safety release cables to disengage the lock.
4. Pull down the lowering handle and hold it until lift has descended completely.  
Lift travel to the lower limit stop is accompanied by an audible signal.
5. Swing arms to full drive-through position and drive the vehicle off the lift.

## MAINTENANCE

**ALWAYS LOCK THE LIFT BEFORE GOING UNDER THE VEHICLE.  
NEVER ALLOW ANYONE TO GO UNDER THE LIFT WHEN RAISING OR LOWERING.**

The maintenance intervals indicated below apply to average workshop use. The lift should be inspected more frequently for severe use applications.

### SAFETY INSTRUCTIONS FOR SERVICING

- Maintenance or repair work by authorized service personnel only.
- Turn off power before doing any maintenance, or repair work.
- Work on pulse generators or proximity switches by authorized service personnel only.
- Work on the electrical equipment by certified electricians only.
- Ensure that ecologically harmful substances are disposed of only in accordance with the appropriate regulations.
- Do not use high pressure / steam jet cleaners or caustic cleaning agents. Risk of damage!
- Do not replace or override the safety devices.

### MAINTENANCE SCHEDULE

**WARNING:** USERS SHOULD ALWAYS INSPECT LIFTING EQUIPMENT AT THE START OF EVERY SHIFT. THESE AND OTHER PERIODIC INSPECTIONS ARE THE RESPONSIBILITY OF THE USER.

The following periodic maintenance is the suggested minimum requirements and minimum intervals; accumulated hours or monthly period, whichever comes sooner. If you hear a noise or see any indication of impending failure, cease operation immediately and inspect, correct and/or replace parts as required.

#### DAILY PRE-OPERATION CHECKS (8 HOURS)

The user should perform daily checks. **ATTENTION!** Daily checks of the safety latch system is very important. Preventative checks could save you from expensive property damage, lost production time, serious personal injury and even death

- Check safety locks audibly and visually while in operation
- Check safety latches for free movement and full engagement with rack
- Check hydraulic connections, and hoses for leakage
- Check chain connections - bends, cracks, and looseness
- Check cables connections - bends, cracks, and looseness
- Check for frayed cables in both raised and lowered position
- Check snap rings at all rollers and sheaves
- Check bolts, nuts, and screws and tighten
- Check wiring and switches for damage
- Keep base plate free of dirt, grease or any other corrosive substances
- Check floor for stress cracks near anchor bolts
- Check swing arm restraints

### WEEKLY MAINTENANCE CHECKS (40 HOURS)

- Check anchor bolts torque to 203 watts per second (N-m/s) for the .75" (19mm) anchor bolts
- Do not use impact wrench
- Check floor for stress cracks near anchor bolts
- Check hydraulic oil level
- Check and tighten bolts and nuts, and screws
- Check cylinder puller assembly for free movement or excessive wear on cylinder yoke or pulley pin
- Check cable pulley for free movement and excessive wear

### YEARLY MAINTENANCE CHECKS

- Lubricate chain
- Grease rub blocks and column surface contacting rub blocks
- Change the hydraulic fluid, good maintenance procedure makes it mandatory to keep hydraulic fluid clean. Operating temperature, type of service, contamination levels, filtration, and chemical composition of fluid should be considered. If operating in a dusty environment, a shorter interval may be required.

The following items should only be performed by a trained maintenance expert:

- Replace hydraulic hoses
- Replace chains and rollers
- Replace cables and sheaves
- Replace or rebuild air and hydraulic cylinders as required
- Replace or rebuild pumps / motors as required
- Check hydraulic and air cylinder rod and rod end (threads) for deformation or damage
- Check cylinder mount for looseness and damage

**We recommend having the lift inspected by quality service personnel every 12 months.**

**Relocating or changing components may cause problems. Each component in the system must be compatible;** an undersized or restricted line will cause a drop in pressure. All valve, pump, and hose connections should be sealed and/or capped until just prior to use. Air hoses can be used to clean fittings and other components. However, the air supply must be filtered and dry to prevent contamination. Most important - cleanliness - contamination is the most frequent cause of malfunction or failure of hydraulic equipment.

### GREASING POINTS

**Slide Tracks: The slide tracks inside the columns should be greased every six months (or more frequently in case of noise generation).**

1. Slightly grease the slide tracks over their entire length using a brush.

## ARM EXTENSIONS

1. Every six months check the support arm extensions for smooth operation.
2. Grease as required.

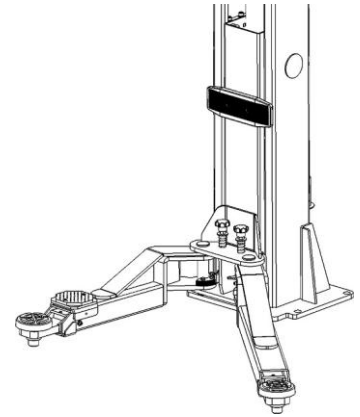

## OPERATIONAL AND WEAR CHECKS

### **RUBBER PADS OF DISC ADAPTERS:**

1. Check the rubber pads weekly for wear.
2. Replace them as required.

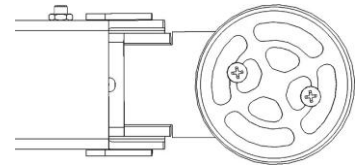

### **ARM RESTRAINTS:**

1. Check the arm restraints for secure engagement weekly.

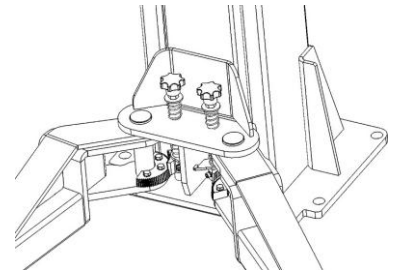

### **LIFT STABILITY:**

1. Every six months, check the nuts of all anchor bolts for correct installation torque.
2. Re-tighten them as required.

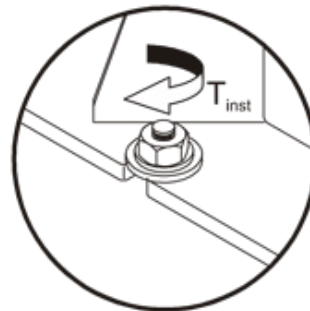

INSTALLATION TORQUE: 80Nm



## CLEANING

**Do not use high pressure/steam jet cleaners or caustic cleaning agents. Risk of damage!**

1. Periodically wash off aggressive substances and treat the lift with oil or wax spray.
2. Repair damage to the paint immediately to prevent corrosion. The RAL number is available through the manufacturer, or could be ordered directly from Eagle Equipment.

## TROUBLESHOOTING

TROUBLE	DIAGNOSIS	SOLUTION
Lift does not respond.	Main switch is off	Turn on main switch
	Main fuse defective	Replace main fuse
Motor starts up, pressure build-up insufficient to raise load.	Lowering screw open	Close lowering screw
	Lowering valve permanently open	Contact service
	Hydraulic system leakage	Remove leakage
	Low fluid level	Check fluid level, add fluid as required
	Load on lift too heavy	Reduce load, observe rated load capacity
Level difference between carriage is too big	Equalizing cables maladjusted	Contact service
Lift cannot be lowered	Latch release defective	Contact service

## EAGLE EQUIPMENT LIFT WARRANTY

Eagle Equipment warrants to the original retail purchaser of an Eagle Automotive Lift that, under normal use and service within the United States and Canada, it will repair or replace, at its sole discretion, any part found to be defective in material or workmanship during the applicable warranty period.

### **Warranty Coverage**

- **Structure:** Five (5) years from the date of purchase
- **Hydraulic Components:** Two (2) years from the date of purchase
- **Electric/Hydraulic Power Unit:** One (1) year from the date of purchase

This warranty covers replacement parts only. The purchaser is responsible for all labor, travel, shipping, installation, and other related costs.

### **Exclusions**

This warranty does not apply to any lift that:

1. Has not been operated or maintained in accordance with Eagle Equipment's instructions and specifications.
2. Has been abused, misused, neglected, modified, altered, or improperly maintained.
3. Has been improperly installed, assembled, or repaired.

### **Additional Limitations**

This warranty is non-transferable and applies only to the original retail purchaser. The determination of whether a component is defective and the appropriate remedy shall be made by Eagle Equipment in its sole discretion. Eagle Equipment may elect to repair or replace the defective component or provide replacement parts as it deems appropriate.

Warranty coverage is limited to the specific defective part or component and does not extend the original warranty period of the replacement part.

This warranty does not cover:

1. Routine maintenance items.
2. Normal wear items, including but not limited to cables, slider blocks, chains, rubber pads, filters, hydraulic fluids, and lubricants.
3. On-site service, labor, travel expenses, freight charges, or related service costs.

## **General Provisions**

Eagle Equipment reserves the right to make improvements or design changes to its products at any time without incurring any obligation to modify, update, or retrofit previously manufactured or sold equipment.

This warranty is the sole and exclusive warranty provided for Eagle Automotive Lift equipment and is in lieu of all other warranties, express or implied, including, but not limited to, any implied warranties of merchantability or fitness for a particular purpose.

To the fullest extent permitted by law, Eagle Equipment shall not be liable for loss of use, loss of time, inconvenience, commercial loss, lost profits, or any incidental, indirect, special, or consequential damage arising from the use or inability to use the equipment.