



# EAG-12K

## Installation & Operation Manual

12,000 Lbs. Capacity Symmetric Two-Post Lift

**READ THIS MANUAL BEFORE INSTALLING OR OPERATING THE LIFT.  
INSPECT THE LIFT UPON DELIVERY. NOTE ANY DAMAGE ON DELIVERY RECEIPT.**

## CONTENTS

Product Description.....	3
Terms and Conditions .....	4-6
Risk of Loss / Freight / Shipping.....	4
Delivery, Unloading and Freight Damage .....	4
Installation.....	5
Warranties .....	5
Returns and Replacements .....	6
Shipping and Damage Claims.....	6
Introduction.....	7
Unpacking.....	8
Before Installation.....	9
Shipment Checklist.....	9
Owner/Employer Responsibilities.....	10
Important Safety Instructions.....	11
Preparation.....	12
Structural Performance.....	12
Power Unit.....	12-13
Control System .....	13
Installation Instructions .....	13-33
Groundwork Foundation Drawing .....	14
Pre-Operation.....	34
Operation .....	37
Lowering The Lift.....	37
Safety Procedures.....	38
Maintenance Schedule.....	38-39
Trouble Shooting.....	40-42
Specifications.....	43
Exploded Drawings.....	45
Parts List .....	46-48
About Us.....	49

# PLEASE READ THE ENTIRE MANUAL BEFORE ANY INSTALLATION AND OPERATION OF LIFT.

## PRODUCT DESCRIPTION

The EAG-12K 2-post, 12,000 lbs. capacity overhead lifts.

This lift is a 12,000 lbs. capacity, 2-post lift. The safety latch system is very similar to an extension ladder.

The safety latch is in contact with the rack as the lift ascends and drops into place as the lift rises. The safety latch engages in rack in 3" (76mm) increments, starting at about 16" (406mm) from the ground. The locking latch must be manually disengaged for the lift to descend. The latch is released by pulling the release handle raising the latch up off the latch rack. Once the raise button is pressed, the latch will automatically re-engage after approximately 3" (76mm) of travel.

**Please read the safety procedures and operation instructions in this manual before operating the lift. Proper installation is very important. Keep this operation manual near the machine at all times. Make sure ALL USERS read and fully understand this manual.** To minimize the chance of making an error in installation, please read this manual carefully before beginning installation. Check with the building owner and/or architect's building plans when applicable. The lift should be installed on a relatively level floor with 5" (152mm), 3,000 PSI (207bar) concrete that has sufficiently cured for a **minimum of 30 days**.

This is a vehicle lift installation/operation manual and no attempt is made or implied herein to instruct the user in lifting methods particular to an individual application. Rather, the contents of this manual are intended as a basis for operation and maintenance of the unit as it stands alone or as it is intended and anticipated to be used in conjunction with other equipment.

Proper application of the equipment described herein is limited to the parameters detailed in the specifications and the uses set forth in the descriptive passages. Any other proposed application of this equipment should be documented and submitted in writing to Eagle Equipment for review. The user assumes full responsibility for any equipment damage, personal injury, or alteration of the equipment described in this manual or any subsequent damages.

## TERMS AND CONDITIONS

Please read these terms of service carefully. Eagle Equipment policy.

These terms and conditions of sale ("Agreement") are applicable to any order placed by you (the "Customer") with and accepted by Eagle Equipment (referred to herein as "EAGLE").

### **Risk of Loss / Freight / Shipping**

All shipments are FOB the EAGLE warehouse, which means that *ownerships of these goods transfers to the customer when they leave our dock*. We use common carriers that have a demonstrated history of timely deliveries and competitive freight rates for the benefit of our customer. Most of these carriers have restrictions on delivering to residential addresses and may require pick-up at freight terminal. There are additional fees for residential, limited access and remote delivery. There are additional fees for lift gate services and scheduled deliveries from the freight carriers.

For items advertised with "Free Shipping"; this applies only to shipments within the Continental United States (excludes Alaska, Hawaii, and Canada and Mexico). Free Freight does not apply to residential, limited access and remote delivery locations. Call the EAGLE sales department at 1-800-336-2776 for a specific freight quote.

---

### **Delivery, Unloading and Freight Damage**

**Unloading:** The customer is responsible for unloading the shipment from the carrier's truck. This may require a forklift and/or lift gate service. Please note that Lifts will require a forklift to unload and they cannot be unloaded using a lift gate vehicle. The EAGLE customer care team can advise you prior to shipping what will be needed to unload your shipment and the approximate weight of the shipment.

**Tracking:** While EAGLE will provide customers with an estimated time of delivery and tracking information, we can't provide a specific time, or schedule a time for that service. The customer can contact the freight carrier directly to schedule a delivery or check on freight delivery status.

**Damages:** Any charges or damages that may be incurred as a result of unloading from the carrier's truck is the customer's responsibility. Depending on your situation, it may be advantageous to have your products shipped to a freight terminal where the freight company's personnel can load it onto your trailer or truck. Please note that Lifts will require a fork lift to unload and they cannot be unloaded using a lift gate vehicle.

**Upon delivery, it is very important that you inspect all of your products immediately.** While we make every attempt to prevent freight damage by properly packaging your order, sometimes damage occurs in transit. For your protection, it is imperative that you note any and all damage you observe on the Delivery Receipt (Bill of Lading) that the carrier will ask you to sign. This will establish your right to file a claim against the freight carrier for this damage. If there are notable shipping damages to your equipment at time of delivery, we advise that you deny the shipment and note "Arrived Damaged" on

the Bill of Lading. We also advise that you take photos of the damage for your freight claim with the freight carrier. The carrier will then return the damaged equipment to their warehouse for inspection. You are then advised to contact EAGLE concerning your damaged shipment.

If there are concealed damages after the carrier has departed (something you hadn't noted on your initial inspection), report them to the freight company **within three days of delivery** in order to preserve your right to file a claim. It is the customer's responsibility to file damage claims against the freight company. EAGLE customer care team is here to assist with the claim if we are contacted within the 3-day window.

**Shortages:** Should you discover any shortages/missing parts, we ask that they be reported to EAGLE's customer service **within 3 days of delivery.**

### **Installation**

EAGLE has a nationwide network of independent installers that we can recommend for your Equipment. These installers do not work for EAGLE. Please call 1-800-336-2776 to find an installer in your area. The contract you enter into with the independent installer is outside the relationship you have with EAGLE and we are not responsible for issues or damages that you may incur with the independent installer.

### **Warranties**

Eagle Equipment is warranted to be free of defects in material and/or workmanship for a period not exceeding one year. Eagle will replace parts only, under this warranty if in Eagle's view there is a defect in material or workmanship. The end user will be responsible to pay shipping of suspected product to the distributor from which they bought the product. The original distributor will arrange for all warranty parts and will pay return shipping, if the product proves to be defective.

This warranty does not cover normal wear, abuse, misuse, shipping damage or damage from lack of required maintenance. This warranty is exclusive and in lieu of all other warranties, expressed or implied. Under no circumstances will Eagle Equipment be liable for consequential or incidental damages. Model and serial numbers must be provided with original proof of purchase, confirming date sold, to original end user, before any claim under this warranty will be considered by Eagle Equipment. To view more details on our Terms of Sale, please visit [www.eagleequip.com](http://www.eagleequip.com).

### **Exclusions:**

This warranty will not apply to any machine:

Which has not been operated or maintained according to specifications

Which has been abused, misused, altered, or improperly maintained

Which has been improperly installed or assembled

### **Other limitations:**

This warranty does not cover:

Parts needed for normal maintenance

Wear parts, which include but are not limited to: cables, hoses, slider blocks, and rubber pads

On-site labor

## Returns and Replacements

In the event that you suspect you have a defective part or product ("part"), please contact our customer care department immediately by calling 336-697-7177, or by emailing [webmaster@eagleequip.com](mailto:webmaster@eagleequip.com). Please include photos and video of the defective equipment for your claim.

If we believe that you have received a defective part, EAGLE will provide you with a return authorization ("RA") number and schedule a time to have your equipment picked up. It is the customer's responsibility to package the equipment for return shipment in sufficient packaging to prevent damage during return. Please note the EAGLE RA number on the packaging.

Upon receiving and inspecting the defective part, EAGLE will provide a replacement part, free of charge, to the customer. If the customer wishes to have the warranty replacement shipped to them prior to the return of the defective product, the customer must pay for the replacement product at shipping. EAGLE will issue the Customer a refund upon receiving the defective product.

In the event the part is determined to not be defective, it will be subject to a minimum restocking fee of 20% and the return freight. Credit for warranty returns to third party vendors will be subject to their return policy. **All returns must be authorized prior to shipping. Contact EAGLE's customer care department for instructions and a return authorization number, which must be issued prior to any return.** Customers may return any unused stock item in the original packaging within 30 days of purchase subject to a 20% restocking fee. All freight charges related to the original shipment and the return will be the responsibility of the customer.

## **INSPECT YOUR LIFT UPON DELIVERY. NOTE ANY DAMAGE ON DELIVERY RECEIPT.**

### SHIPPING AND DAMAGE CLAIMS

**All shipments must be inspected immediately upon receipt.** For your protection, any external damage must be noted on the bill of lading at the time of delivery in order to qualify for a claim against the freight carrier.

**Concealed damage must be reported to the freight company within three (3) days of delivery.** It is the customer's responsibility to file for damage claims against the freight company. Eagle Equipment is not responsible for loss or damages caused by shipping.

Shortages or missing parts must be reported to Eagle Equipment Customer Service (1-800-336-2776) within three (3) days of delivery.

## INTRODUCTION

Thank you for your purchase.

Your lift is the result of decades of research, testing, and development; and represents the most advanced technology on the market.

The care with which you maintain and operate your lift will directly affect its overall performance and longevity.

BE SAFE.

Your lift was designed and built with safety in mind. However, safety relies on proper training and thoughtful use on the part of the operator. DO NOT operate or repair this equipment without reading this manual and the important safety instructions shown inside.

Keep these instructions accessible, and make sure that ALL USERS read this manual.

**PLEASE READ THIS MANUAL IN ITS ENTIRETY BEFORE  
INSTALLING OR OPERATING THIS LIFT.**

**RECORD THE MODEL NUMBER AND THE SERIAL NUMBER**

This information is located on the main post of your lift.

Model Number: \_\_\_\_\_

Serial Number: \_\_\_\_\_

Manufacturing Date: \_\_\_\_\_

**THIS INFORMATION WILL BE REQUIRED  
SHOULD YOU EVER NEED TO CALL IN FOR  
PARTS OR TECHNICAL ASSISTANCE**

For parts assistance, please call: 1-800-336-2776

## **WARNING:**

**Failure to follow the unpacking and assembly directions may cause personal injury and/or impair the operation of this machine.**

**PLEASE READ THOROUGHLY.**

### **UNPACKING**

1. Your lift comes packaged as a single unit. A fork-lift, floor-jack or other heavy-lifting equipment may be necessary to separate the components. Exercise caution when disassembling the packaged lift, as shifting may have occurred during shipping.
2. Carefully remove the shipping bands and brackets from the lift. Check for any obvious shipping damage. Remember to report any shipping damage to the carrier and make a notation on the delivery receipt. Save all bolts, nuts and washers securing the shipping brackets, as these may be used in the assembly of the lift.
3. The unit is composed of several main components.
4. An accessory box is included with the lift and contains smaller components.
5. Unstrap and remove the power unit box from the packaged lift. Literature such as the installation manual, warranty card, and serial number plate is included inside this box. Inspect the power unit and note any possible shipping damage on the shipping bill.

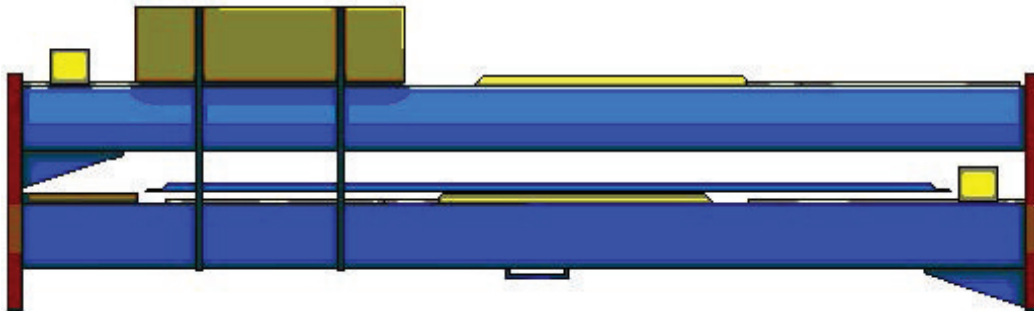

**Shipments must be inspected immediately upon receipt.**

**External damage must be noted on the bill of lading.**

**Concealed damages must be reported to the freight company within three days of delivery.**

**Shortages must be reported to Eagle Equipment within three days of delivery:**

**1-800-336-2776.**

## BEFORE INSTALLATION

The following tools and equipment are needed:

- 3/4" Concrete drill
- Hammer (14 oz. min.)
- Level (4-ft minimum)
- Metric combination wrench set, (10 to 32 mm)
- Ratchet & Sockets sized as above
- metric hex key set, (3mm,5mm,8mm)
- 12" Adjustable wrench
- Needle nose pliers
- Flat pry bar (for installing shims)
- Chalk Line
- Tape Measure 25'
- Locking Pliers (vice grips)
- AW 32 Hydraulic Oil
- Teflon Tape

This lift requires 220VAC 20A max. Fuse at 60 Hz single-phase. Wiring must meet code. Please ensure that all wiring is capable of handling the loads and voltages applicable. The wiring of this device must be done only by a qualified electrician to ensure that you meet your local electrical code.

### SHIPMENT CHECKLIST

- 4 - Swing Arms
- 3 - Hydraulic Hoses
- 1 - Set of Drop-in Extensions
- 1 - Overhead Cross Bars
- 2 - Columns and 2 -Column Extensions 2- Cylinders
- 1 - Small Cable ( for safety release)
- 2 - Safety Side Covers
- 12- Anchor Bolts
- 1 - Hydraulic Power Pack
- 1 - Document Envelope
- 1 - Electric limit switch/cable, bar and brackets (for overhead travel limit)



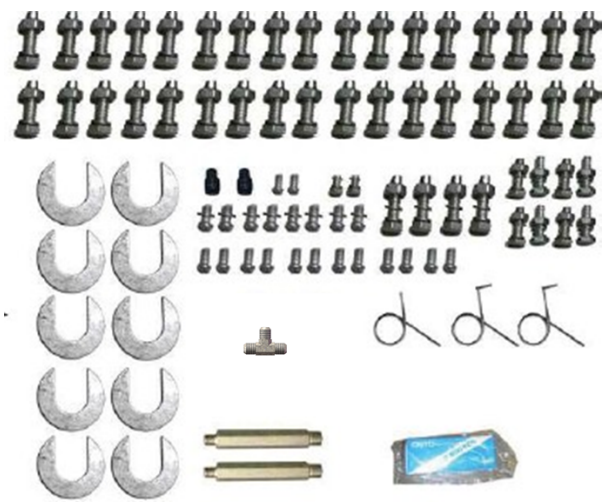
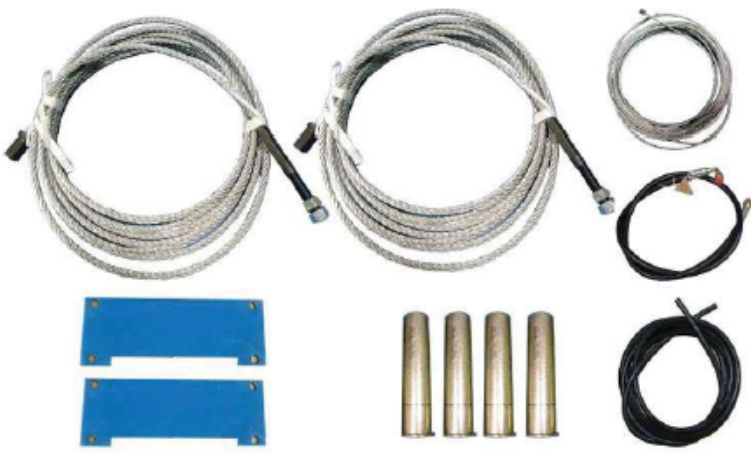

## OWNER/EMPLOYER RESPONSIBILITIES

The owner/employer is responsible for proper installation and maintenance of this lift according to this manual. The owner/employer of the lift is responsible for acquiring locally required authorizations such as permits, including electrical and seismic permits. Seismic permits will require the owner/employer to contract a locally-licensed professional engineer or engineering firm that is knowledgeable about local codes and equipment anchoring.

The owner/employer shall ensure that lift operators are qualified and that they are trained in the safe use and operation of the lift using the lift manufacturer's operating instruction.

The owner/employer shall establish procedures to periodically inspect the lift in accordance the lift manufacturer's instructions ***Safety Requirements for Operation, Inspection and Maintenance***. The owner/employer shall ensure that the lift inspectors are qualified and that they are adequately trained in the inspection of the lift.

The owner/employer shall establish procedures to periodically maintain the lift in accordance the lift manufacturer's instructions . The owner/employer shall ensure that the lift maintenance personnel are qualified and that they are adequately trained in the maintenance of the lift .  
The owner/employer shall maintain records of periodic maintenance.

The owner/employer shall display the lift manufacturer's operating instructions in a conspicuous location in the lift area convenient to the operator.

The owner/employer shall not modify the lift in any manner with prior written consent of the manufacturer.

## IMPORTANT SAFETY INSTRUCTIONS

### READ THESE SAFETY INSTRUCTIONS THOROUGHLY

1. Read and understand all operation and safety warning procedures before operating the lift.
2. Keep hands and feet clear. Remove hands and feet from any moving parts. Keep feet clear of lift when lowering. Avoid pinch points.
3. Keep work area clean. Cluttered work areas invite injuries. Consider work area environment. Do not expose equipment to rain. Do not use in damp or wet locations. Keep area well lit.
4. Only trained personnel should operate this lift. All non-trained personnel should be kept away from the work area. Never let non-trained personnel come in contact with or operate the lift.
5. Use the lift correctly. Never use lifting adapters other than those provided by the manufacturer, in any manner other than intended. Only use the vehicle manufacturer's recommended lift points.
6. Do not override self-closing manuals. Do not overload the lift. Load capacity is indicated on lift nameplate.
7. Remain clear of lift when raising or lowering vehicle. Clear area if vehicle is in danger of falling.
8. After positioning the vehicle, apply the parking break. Make sure the vehicle doors are closed during raising and lowering cycles. Do not allow anyone on the lift or inside the raised vehicle.
9. Always ensure that the safeties are engaged before any attempt is made to work on or near vehicle. After raising the vehicle briefly, stop and check the pad adapters for secure contact. Always lift vehicle using all four adapters.
10. Use caution when removing or installing heavy components (center-of-gravity displacement).
11. Dress properly. Non-skid, steel-toe foot-wear and safety glasses is recommended when operating lift.
12. Guard against electric shock. This lift must be grounded while in use to protect the operator from electric shock. Never connect the ground wire to a live terminal. This is for ground only.
13. **DANGER:** The power unit used on this lift contains high voltage. Disconnect power at the receptacle before performing any electrical repairs. Secure plug so that it cannot be accidentally plugged in during service.
14. **WARNING:** Risk of explosion. This equipment has internal arcing or sparking parts which should not be exposed to flammable vapors. This machine should not be located in a recessed area or below floor level.
15. Maintain with care. Keep lift clean for better and safer performance. Follow manual for proper lubrication and maintenance instructions. Keep control handles and/or buttons dry, clean and free from grease and oil. Protect all parts of the electrical equipment from humidity and moisture.
16. Carefully inspect the lift on a regular basis. Perform maintenance according to the maintenance schedule.
17. Check for damaged parts. Check alignment of moving parts, breakage of parts or any condition that may affect its operation. Do not use lift if any component is broken or damaged.
18. Never remove safety related components from the lift. Do not use the lift if safety related components are damaged or missing.
19. Stay alert. Watch what you are doing. Use common sense. Be aware.

### Working temperatures:

1. Ambient temperature: 40-105° Fahrenheit
2. Humidity: 30-95%
3. Transportation/storage temperature: 77-131° Fahrenheit, not exceeding 24 hours at up to 158° F
4. Installation altitude max: 3280 feet (1000m)

## **PREPARATION**

The installation of this lift is relatively simple and can be accomplished by two (2) people in a few hours. This lift is not intended for outdoor use. **If it is installed outdoors, your Eagle Equipment warranty is null and void.**

### **Model # EAG-12**

Surface-mounted two-post overhead *symmetrical* and asymmetrical lift  
12,000 lbs. capacity

## **STRUCTURAL PERFORMANCE**

The main components are the towers, lifting carriages, swing arms, cylinders, cables and power unit. Arms and carriages have locking mechanisms for simple and safe operation.

Depressing the switch on the power unit raises the lift. Releasing the switch stops the lift. Lift should always be settled on the carriage locking mechanisms. To lower the lift, simply raise the carriages up off the locks, pull on the small ringed cables below both carriages to disengage the locks, and depress the lowering handle.

Arms rotate and telescope for easy use. Adapters are included for raising the height of the basepad at the end of the arm. Swing arm locks automatically engage as the carriages rise, and disengage once they are lowered to the floor.

## **POWER UNIT**

This lift requires 220VAC 20A max. Fuse at 60 Hz single-phase. Wiring must meet code. Please ensure that all wiring is capable of handling the loads and voltages applicable. The wiring of this device must be done only by a qualified electrician to ensure that you meet your local electrical code.

The hydraulic system uses a hydraulic power unit, a system that has a manual regulator function, rotating the mediate relief valve screws. Can regulate mediation system pressure.

**NOTE:** The pressure of the system is adjusted before purchase, the user can not adjust personally. After starting the motor, the cylinder moves to achieve lift. After motor stall, the one-way valve and

the unloading valve seal the machine to maintain the original height of tank will not drop. Press the unloading valve handle to lower the lift.

## CONTROL SYSTEM

Connect the power supply, press power button, when desired height has been reached, release the button to stop the lift. Press the lowering valve handle to lower the lift. Release the handle to stop the lift.

When the desired height has been reached, let the lift fall down without release the safety lock. This will ensure the lock engages, preventing a sudden drop. When working, implementation of the latch is crucial. Do not operate the lift if the safety lock does not engage.

## INSTALLATION INSTRUCTIONS

### **PLEASE READ INSTRUCTIONS BEFORE OPERATING THE LIFT.**

#### **STEP ONE – UNPACKING**

1. Cut the metal banding with an appropriate tool. **CAUTION: When cutting bands. Use gloves and eye protection.** The tension released may cause the banding to spring in any direction cutting you or those around you.
2. Carefully remove the plastic packaging material around the lift.
3. Remove the hydraulic power unit. Store this unit on its side until needed.
4. Lift cross bar off and remove plastic wrap, being careful not to damage the limit switch.
5. Remove loose components from top column, and lay out on the floor close by.
6. Using a lifting device, support the top column, unbolt and remove the shipping brackets from this column only. Lift column off and stand upright.
7. Remove loose components from bottom column and layout on the floor near by.
8. Ensure all components are accounted for.
9. Using a lifting device support the bottom column, unbolt and remove the shipping brackets from this column stand upright.
10. After installation, deliver this manual, all other materials and instruction manuals furnished with this lift to the owner/employer/user.

#### **STEP TWO – SITE SELECTION**

1. This equipment is intended for **indoor use only**, with an operating temperature range of 40-105°F (5-40°C).
2. Locate lift according to architectural drawing if available.
3. **13-feet is the minimum height requirement to install and service this lift.**
4. The space above the lift installation should be free of overhead obstructions such as wiring, cables, buss boxes, building supports, heaters, duct work etc.
5. Stand the lift columns up in the space where they will be installed and ensure that there is enough working space around the lift. See step three - Site Layout, for column spacing.
6. Visually inspect the concrete in the lift installation area for cracks, flaking or spalled concrete. **Do not install lift columns within 6" of an expansion joint or the edge of the concrete slab.**

Install the hydraulic hose and lock release cab brackets on the extension columns .

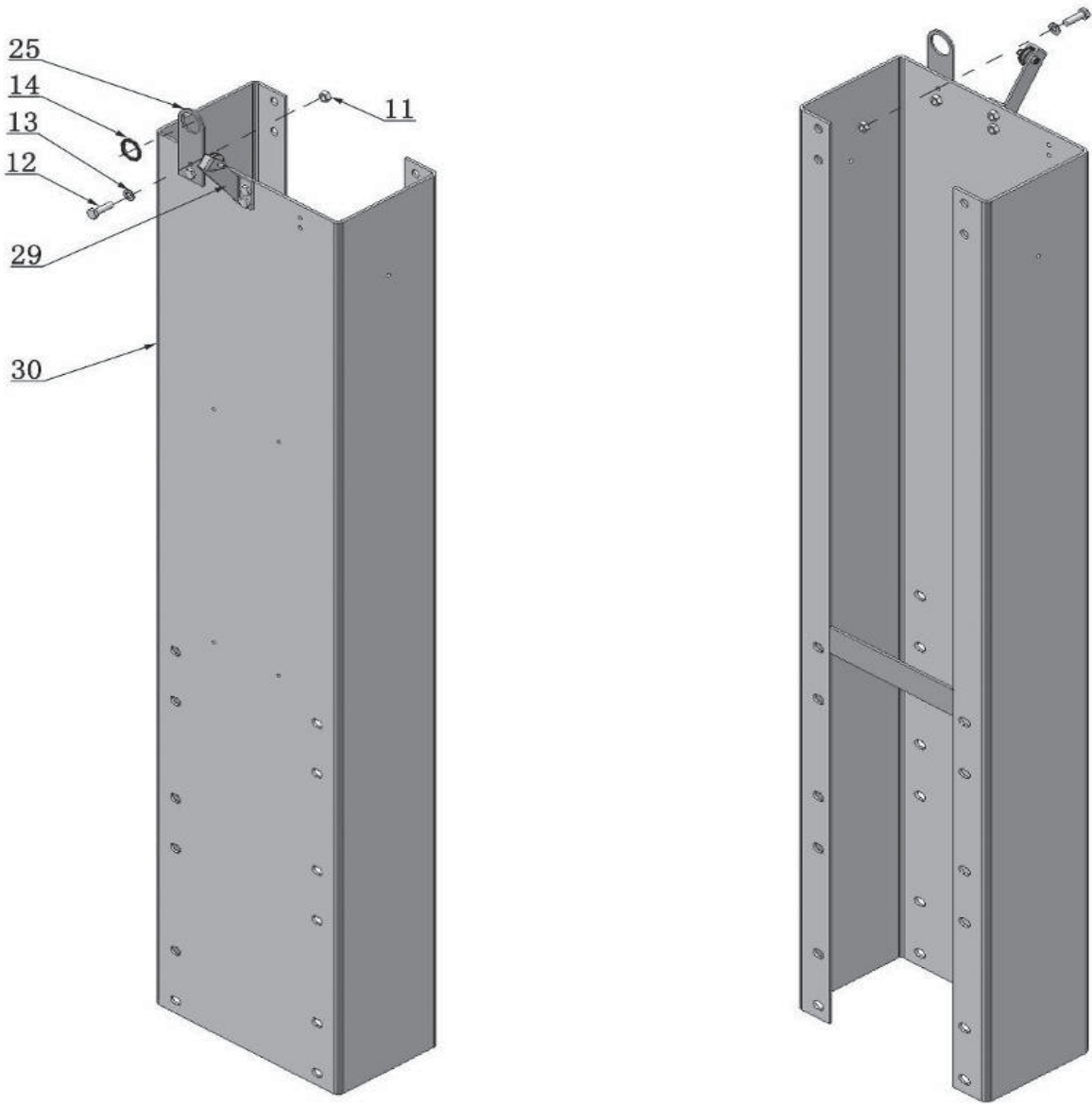

Use **M6 x 20** Hex Bolts with **M6** Nylock Nut & **M6** Washer

# Install hydraulic cylinders

Connect the extended straight fitting and 90° fitting. Install the cylinders through the carriages (**See Below**).

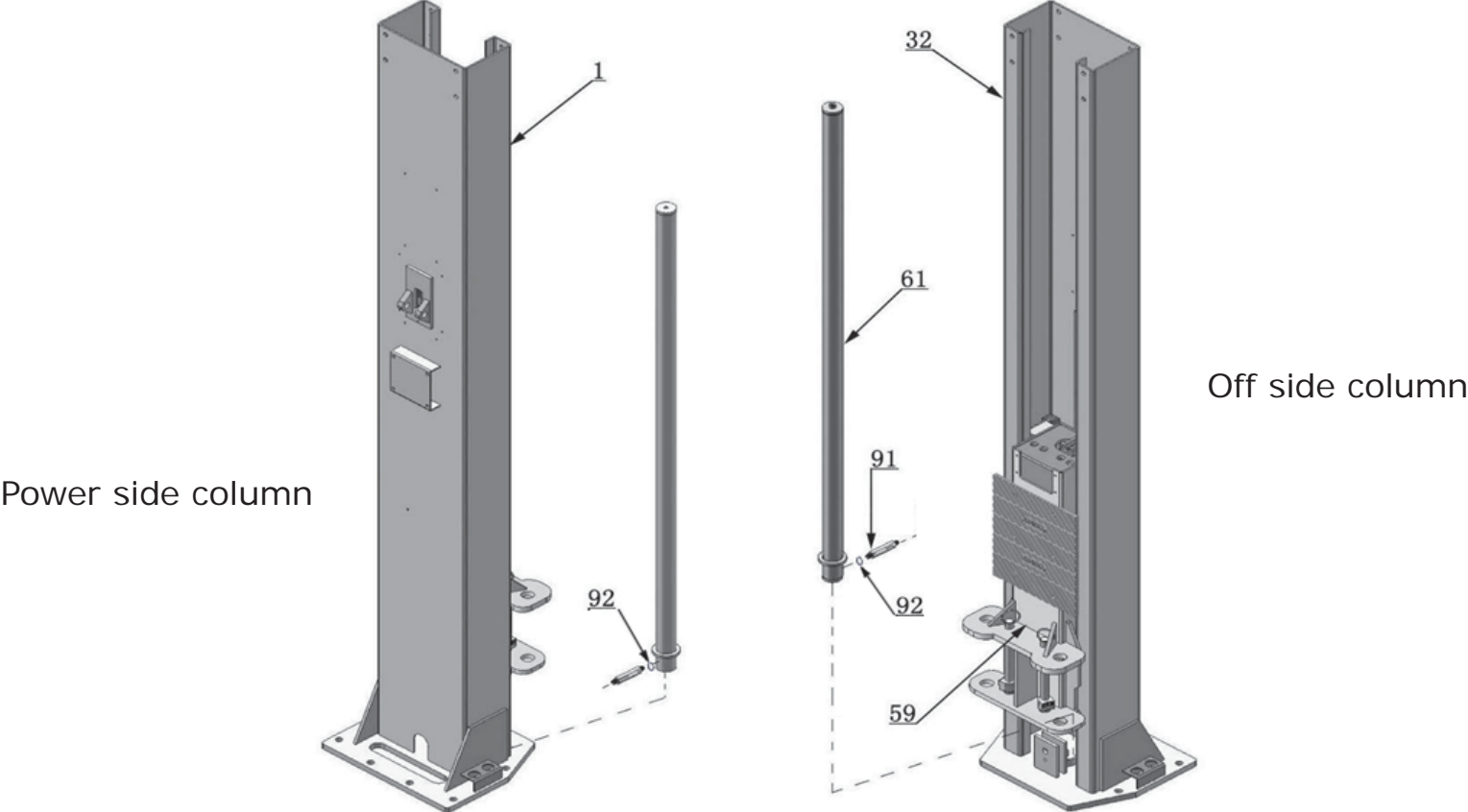

## **Install columns (Use M12 x 35 Hex Bolt, Nylock Nut & Washer to install extensions)**

Lay down the two columns on the installation site parallel of each other. Position the power side column according to the actual installation site. This lift is designed with 2 sectional columns. Adjust the height according to your ceiling height.

1. When the ceiling height is over 4500mm (177 1/8"), connect the outer columns to the lower holes .

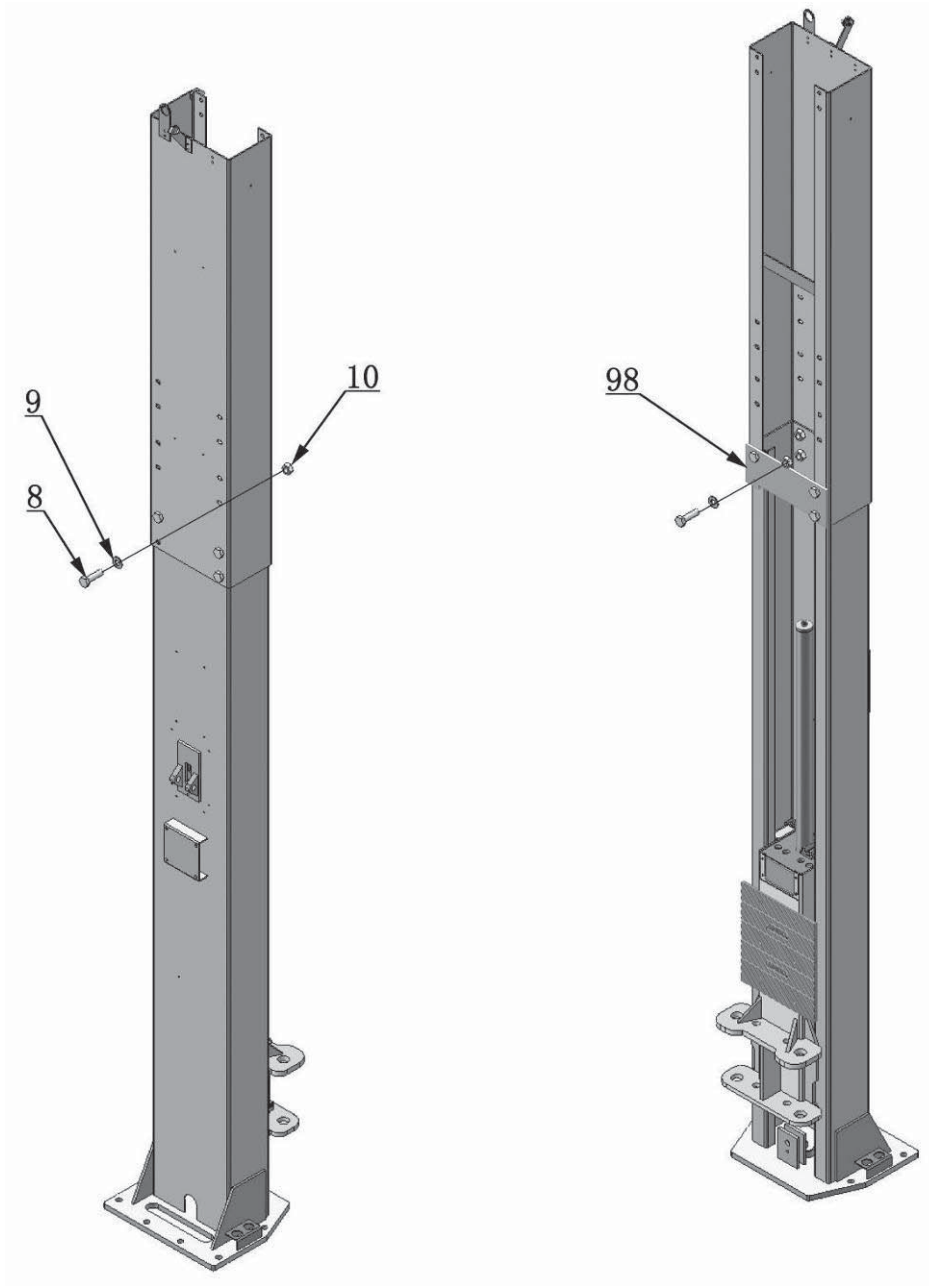

2. When the ceiling height is over 4200mm (165 3/8") but less than 4500mm (177 1/8"), connect the outer columns to the middle holes .

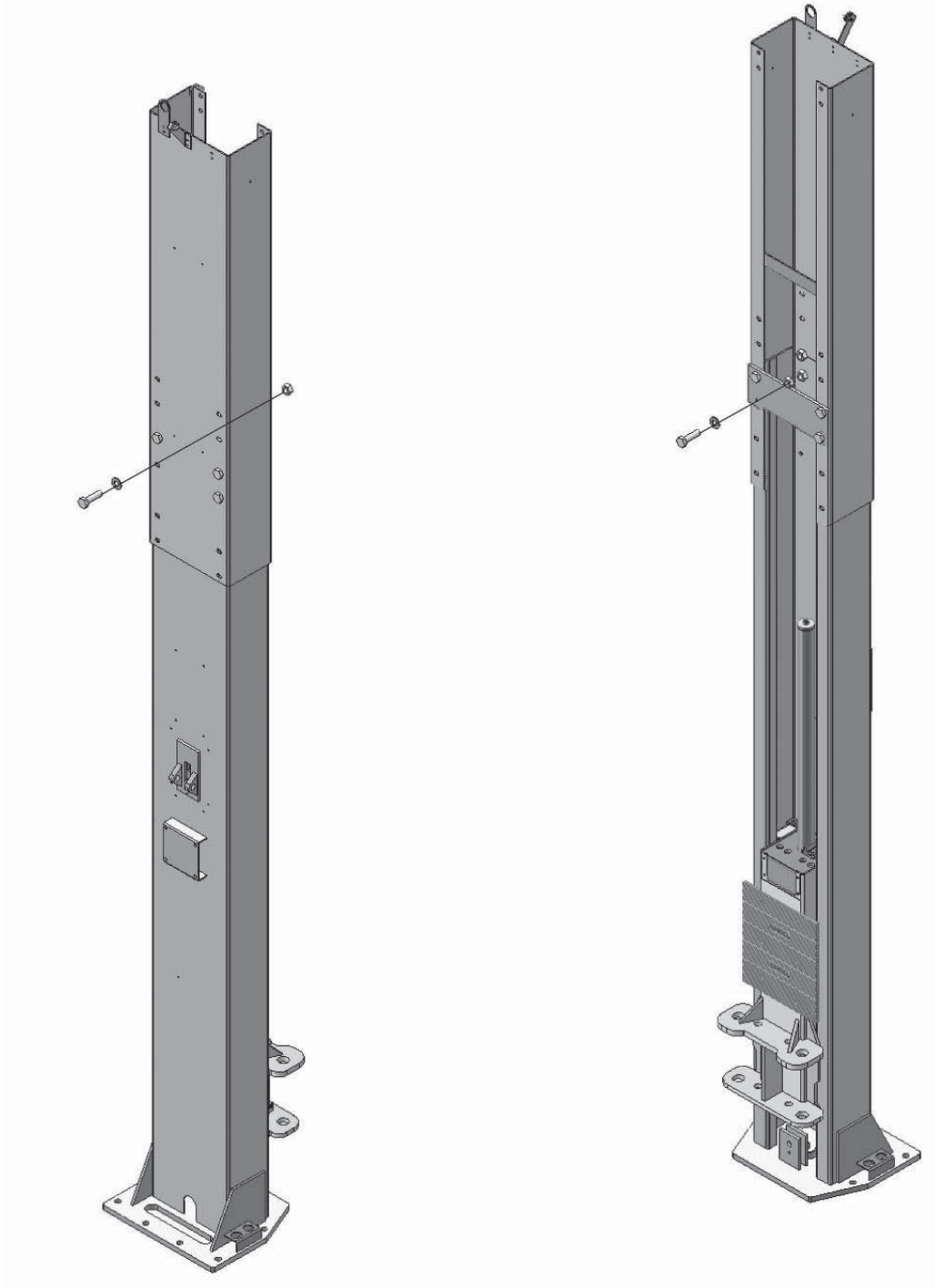

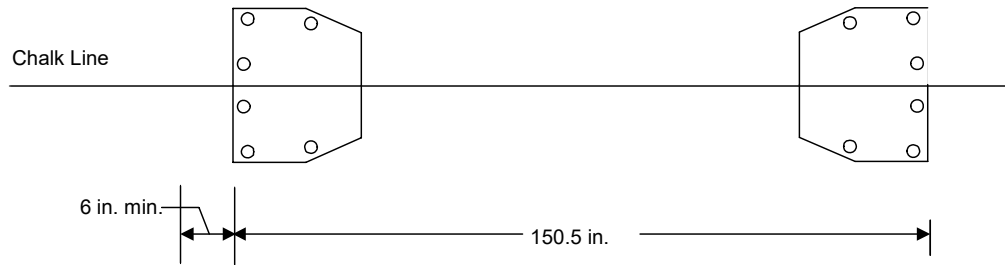

Figure 1 Column Layout

7. **This lift must be installed on concrete, where the concrete is at least 5" thick, has a compressive strength of 3000 PSI and has been cured for a minimum of 30 days. Do not install this lift on any surface other than concrete.**
8. The slope of the floor must not exceed 1-inch in ten feet.
9. If the floor is of questionable quality or has excessive slope, pour a new, level concrete pad that will meet those specifications.

**STEP THREE – SITE LAYOUT**

1. Determine the entry end of the bay area and locate the lift centerline at least 84" for an asymmetrical lift, or 96" for a symmetrical lift, from any obstruction on either side.
2. Use a chalk line to layout the centerline of the bay parallel to the entry direction of the vehicle.
3. Using the chalk line again to layout a line 90° to the center line at least 8' for an asymmetrical lift, or 10' for a symmetrical lift, from the nearest obstruction in front of the columns.
4. align the column center to the chalk line as shown in Figure 1.
5. Move the other column into place, center to the chalk line as shown in Figure 1.
6. Check all dimensions and the squareness of lines before proceeding to the next step.

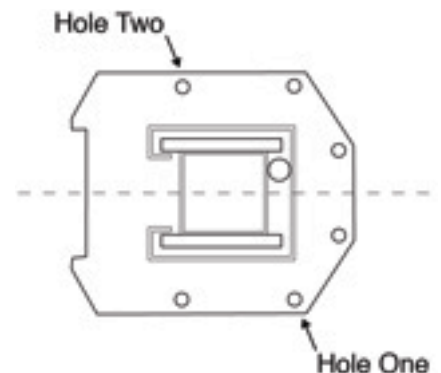
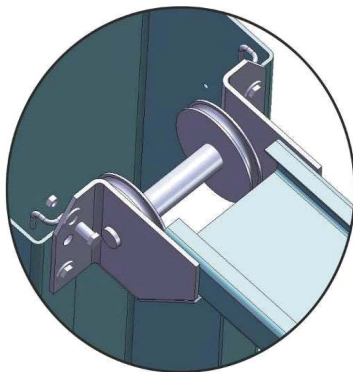

Figure 2

## STEP FOUR – MOUNTING THE COLUMNS

1. Starting with the power side column, drill the concrete with a  $\frac{3}{4}$  concrete bit at least 5 inches deep. Do not ream the hole with the drill or allow the drill to wobble as this will enlarge the hole and reduce the holding power of the anchors making the lift unsafe. Start at Hole 1 as shown in Figure 2. Be careful not to move the column. Drop a bolt into Hole 1 (to help maintain alignment do not force the bolt down at this time). Check the column alignment to the 90° chalk line as indicated in Step 3 - Item 5 above. Drill a hole at hole 2 as shown in Figure 2. Drop a bolt into Hole 2, this should help prevent movement of the column. Drill the remaining 4 holes on this column.
2. Remove the bolts you dropped in to the holes and clear all dust from all the holes and from under column base plate.
3. Assemble the washers and nuts onto each anchor. Ensure that the thread on the anchor is flush to the top of the nut, drop a bolt into each hole and tap down until the washer is about  $\frac{1}{2}$  inch above the base plate.
4. Roughly level column using shims as necessary under the base plate. When the column is plumb, tap down all bolts until the washers on the bolts contact the base plate. Tighten the nuts and re-check the level, loosen, re-shim and re-tighten as necessary until the column is tight and dead plumb. It is very important that the column be plumb.
5. With the other column standing in place, (do not drill holes at this time), use a lifting device to raise the overhead cross bar and place into position on the top of the two columns with the open channel facing up. Using bolts provided, screw in cross bar but do not tighten bolts at this time.
6. Measure the distance between the closest corners of the columns as shown in Figure 3. The distance between the top and the bottom of the columns at this point must be the same. Adjust the loose column until the distance between the two columns is the same top and bottom (parallel), Check that the locator marks of the loose column are still aligned with the chalk line.
7. Before drilling the concrete for the other column check all dimensions and locations. Repeat steps 1-3 above for the loose column. Being careful not to move the column.
8. When you plumb this column, it must only be plumbed front to back as the distance between the columns must be the same top and bottom.
9. Tighten the overhead top beam bolts.

Hook on to the  
extension columns



Tighten the bolts

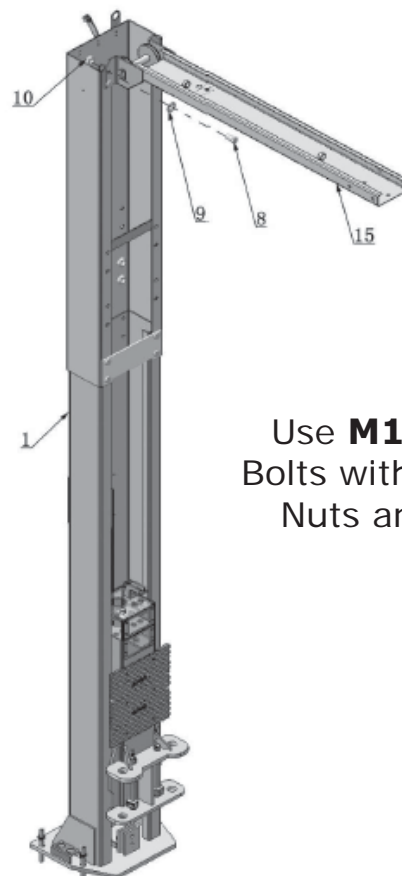

Use **M12 x 35** Hex  
Bolts with **M12** Nylock  
Nuts and Washers

Assemble the over head top beam; tighten the anchor bolts .

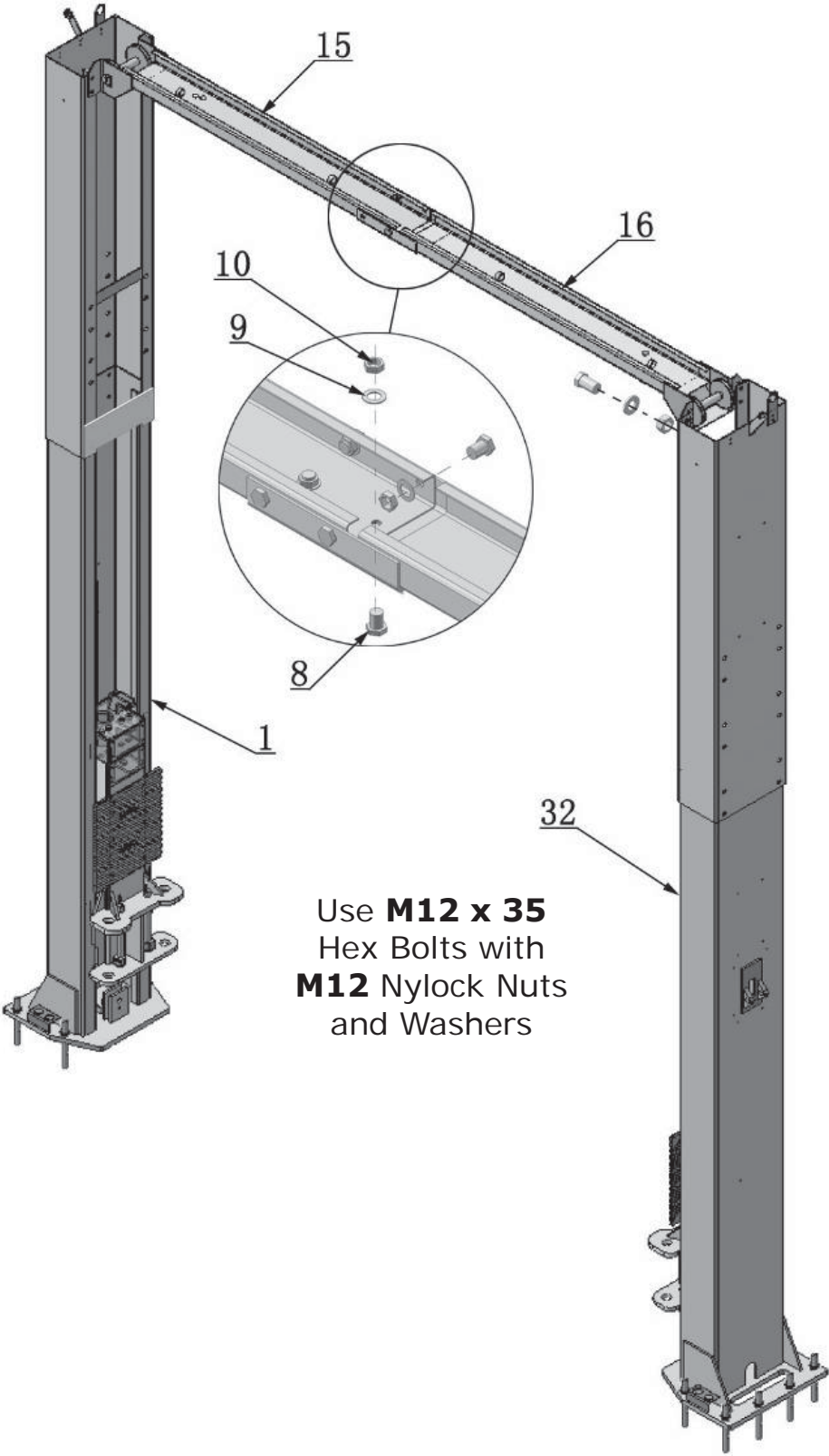

Use **M12 x 35**  
Hex Bolts with  
**M12** Nylock Nuts  
and Washers

# Install the limit control bar and limit switch

Use **M12 x 30** Hex Bolts with **M12** Nylock Nuts and Washers to install control bar brackets

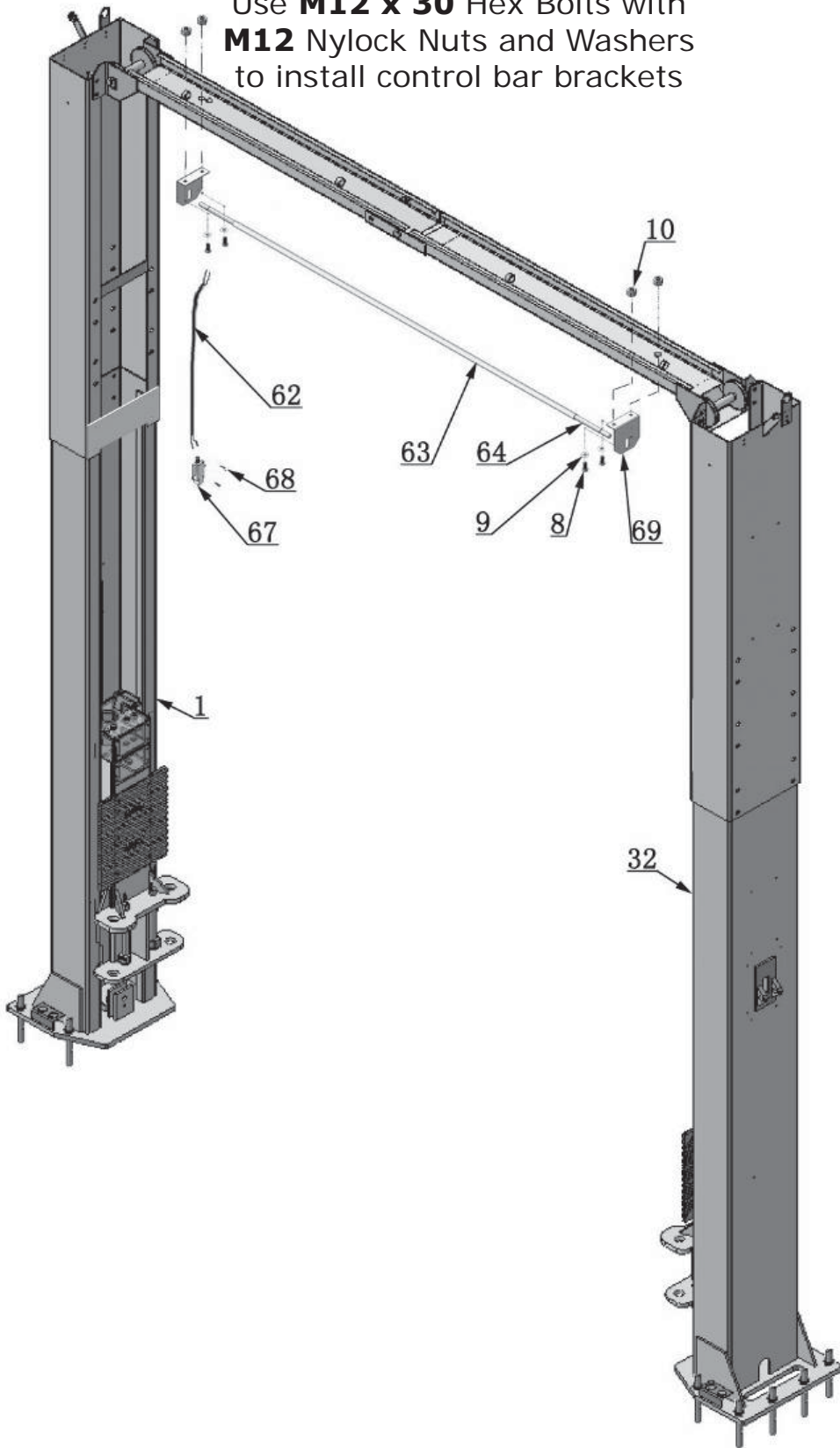

Limit Switch connected with Cable

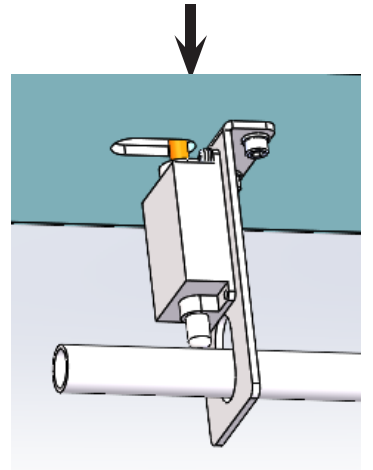

65

**NC: Normal contact**

# Install safety device .

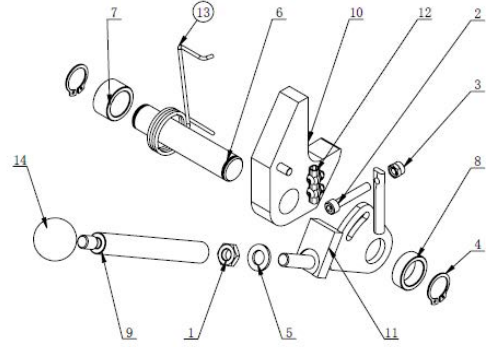

ITEM	PART.No	DESCRIPTION	QT. Y
1	GB6172. 1-M10	HEXANGULAR THIN NUT	1
2	GB70. 1-M6×35	INNER HEXA CYLINDRICAL SCREW	1
3	GB889. 1-M6	1-TYPE PREVAILING TORQUE TYPE HEXAGON LOCK NUT	1
4	GB894. 2-20	SHAFT ELATIC RETAINING RING B-TYPE	2
5	GB95-10	FLAT WASHER	1
6	J272-1230001	Shaft	1
7	J272-1230002	Spacer	1
8	J272-1230004	Spacer	1
9	J272-1230005	Operating Lever	1
10	J272-1231000	Lock Block Welding Assembly	1
11	J272-1232000	Rotating Plate Weldment	1
12	J272-1233000	Wire Rope Clamp	1
13	J276-1000009	Locking Tooth Return Spring	1
14	MH-12-1360011	HAND LEVER	1

Power side safety device

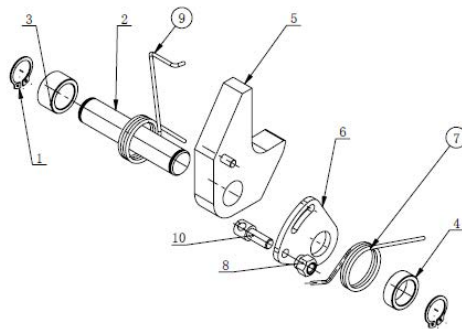
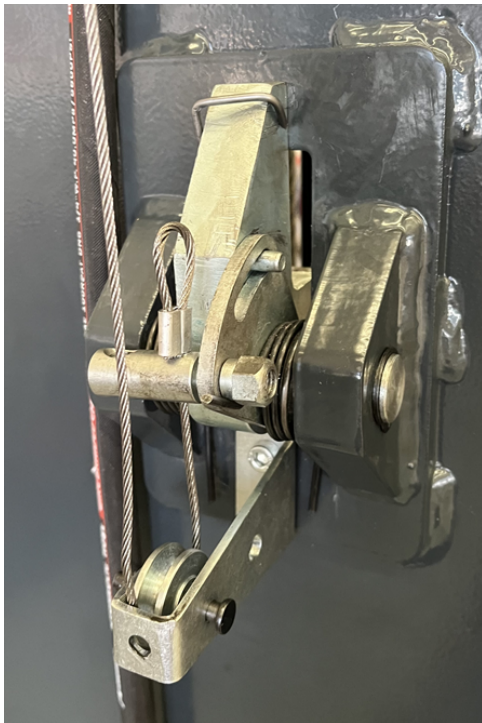

ITEM	PART.No	DESCRIPTION	QT. Y
1	GB6172. 1-M10	HEXANGULAR THIN NUT	1
2	J272-1230001	Shaft	1
3	J272-1230002	Spacer	1
4	J272-1230004	Spacer	1
5	J272-1231000	Lock Block Welding Assembly	1
6	J272-1320001	Turntable	1
7	J272-1320003	SPRING	1
8	J272-1320004	SPHERIC HEXANGULAR NUT	1
9	J276-1000009	Locking Tooth Return Spring	1
10	J276-1000017	Shaft	1

Offside safety device

**Lift the carriages up by hand and lock them at the same level .**

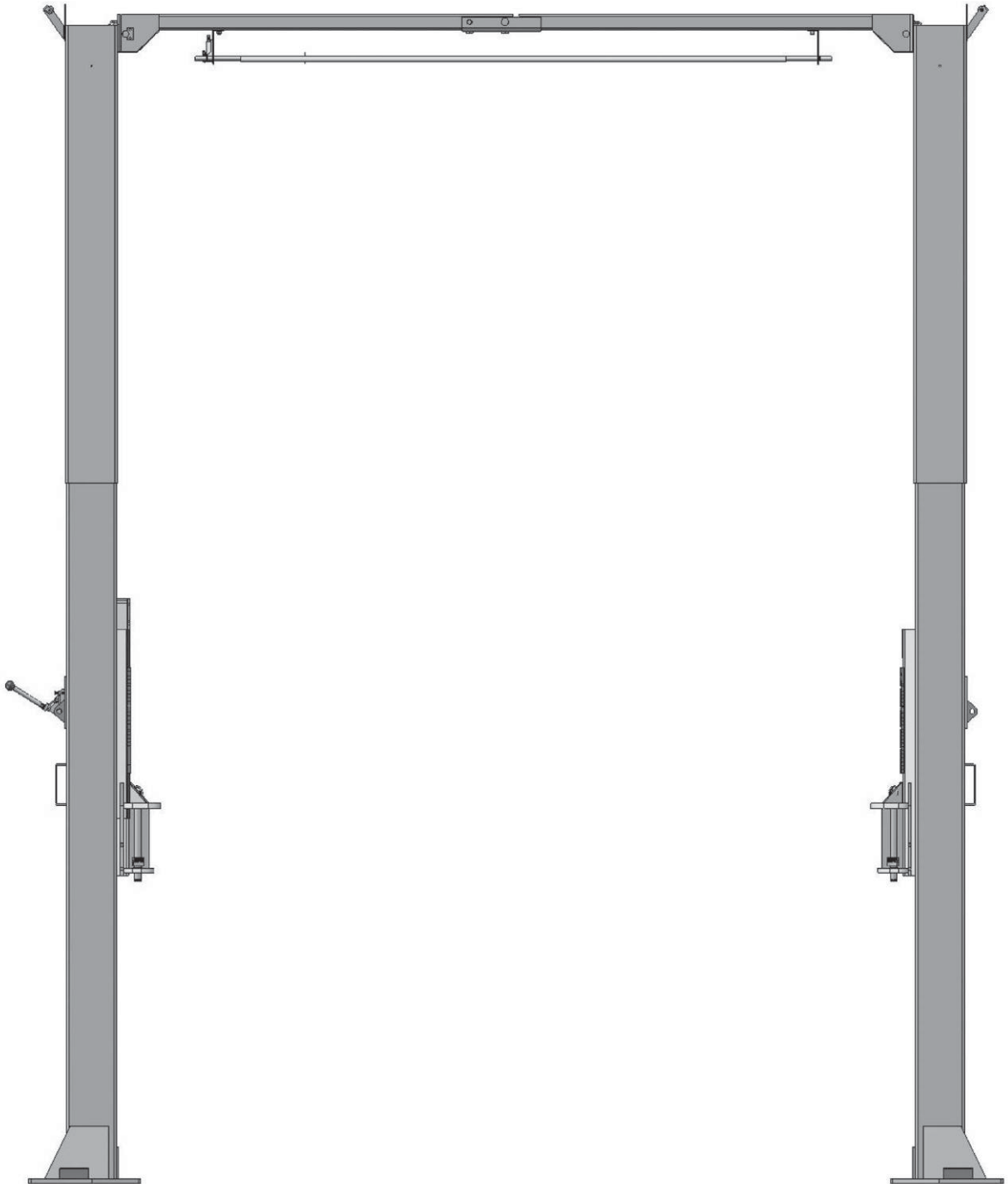

# Install cables

## 1. High setting cable connection, suitable for ceiling height over 4500mm (177 -1/8").

1.1 Take out the carriages' plastic covers, cable passes through from the bottom of the carriages and pulled out from the openings of the carriages, then screw the two cable nuts .

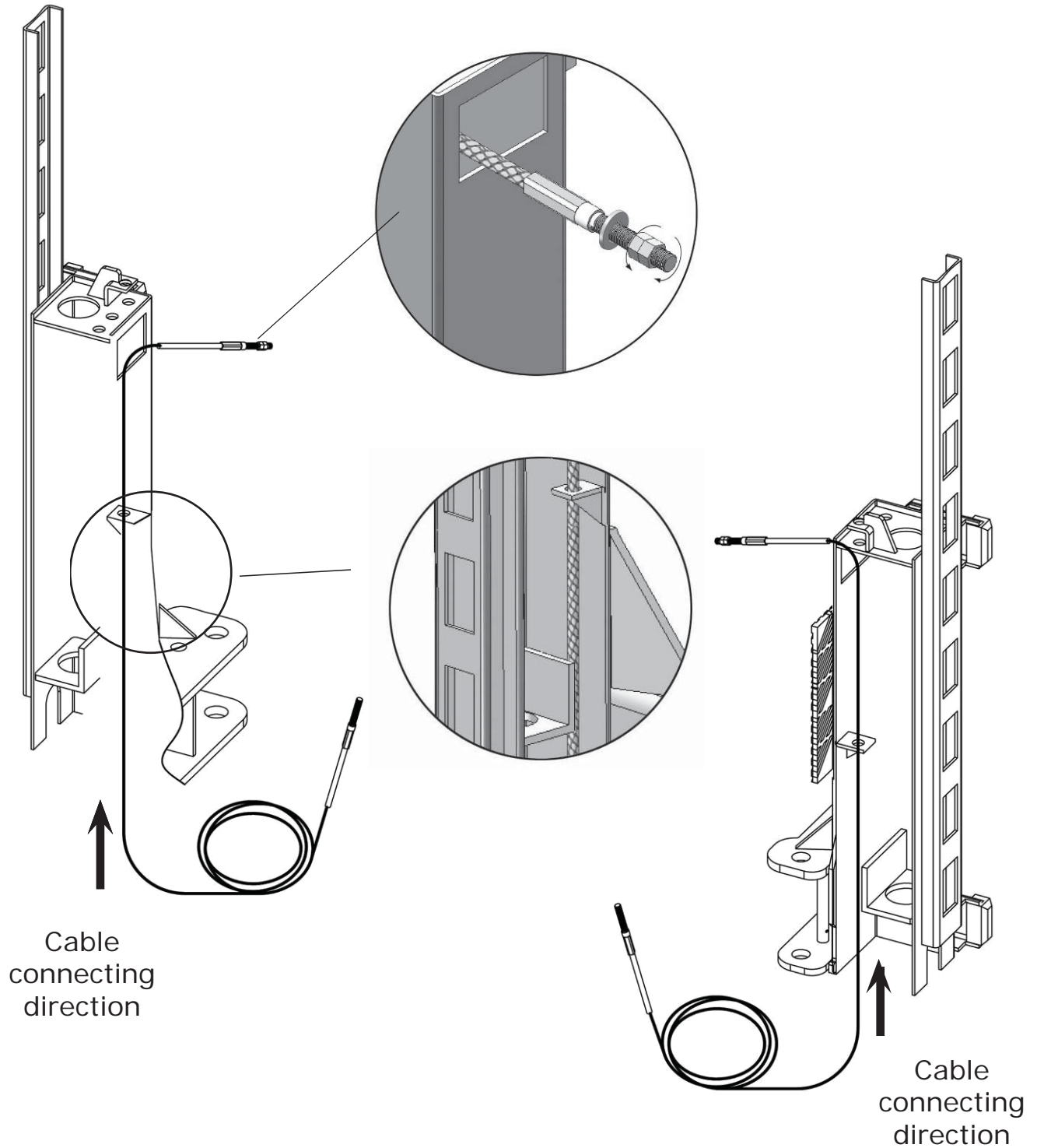

## 1.2 Connecting the cable for high setting .

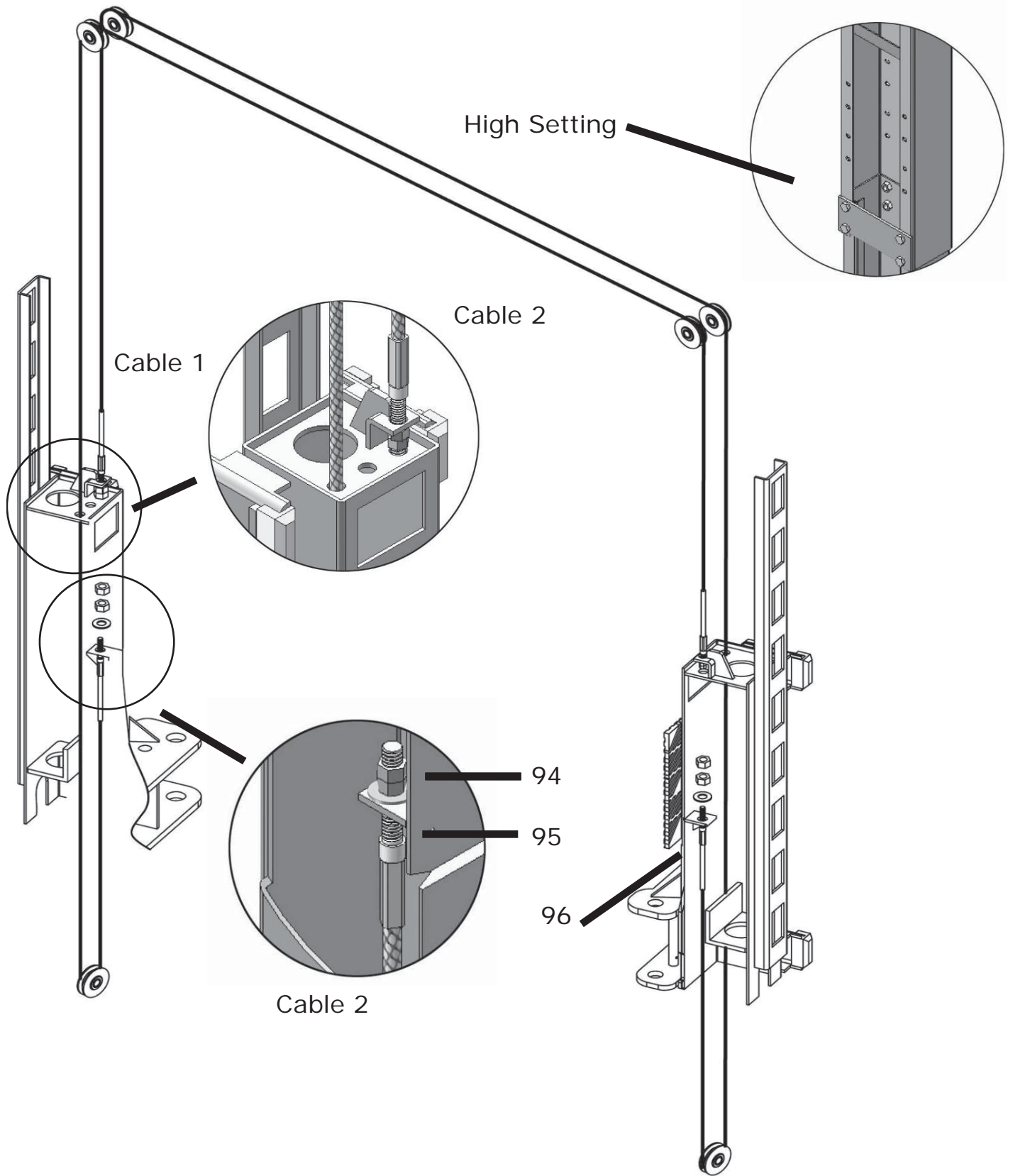

**Low setting cable connection**, suitable for ceiling heights between 4200mm (165 3/8") to 4500mm (177 1/8") ).

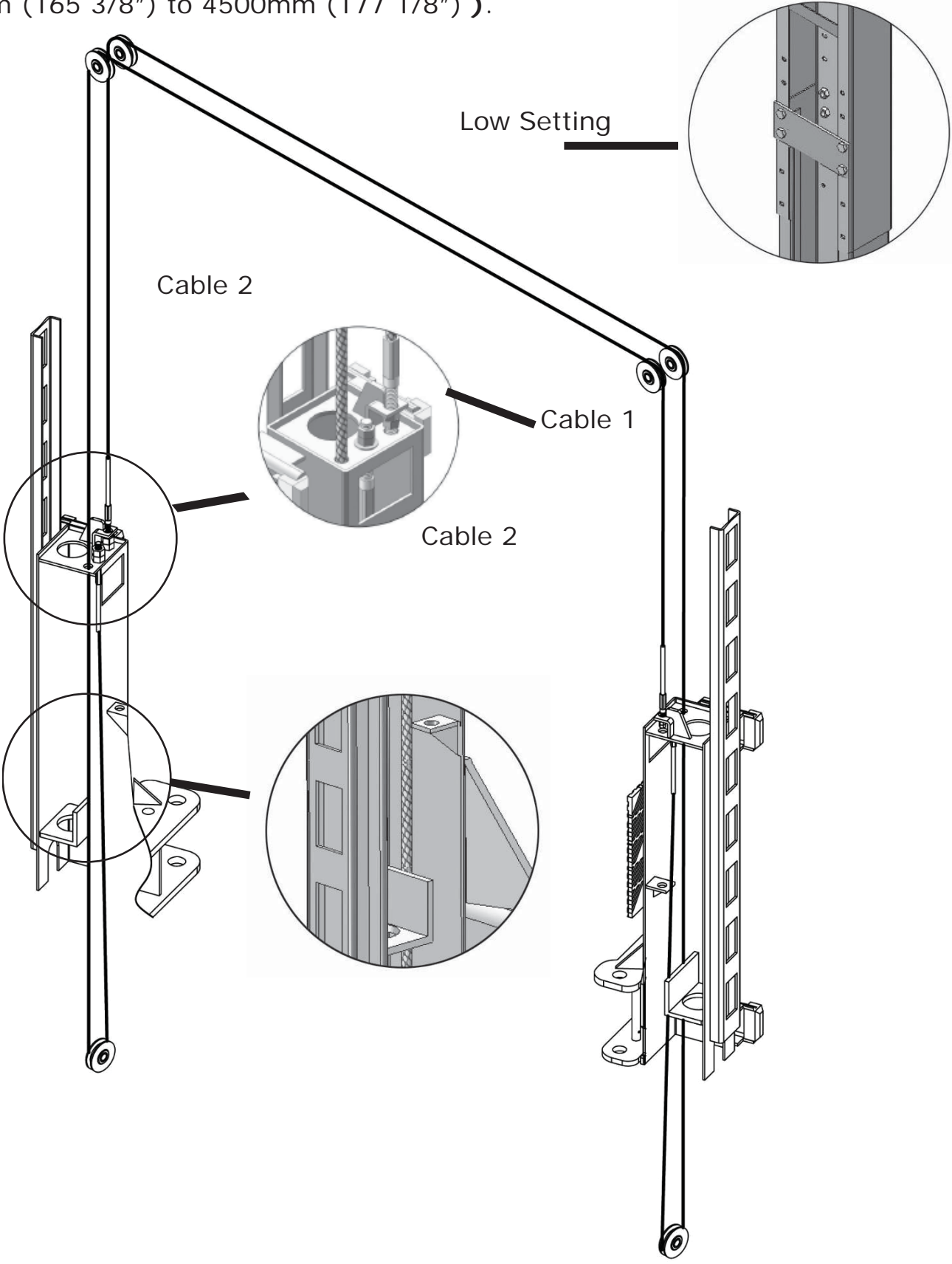

## Install power unit

Use **M8 x 25** Hex Bolts  
with **M8** Nuts & Washers

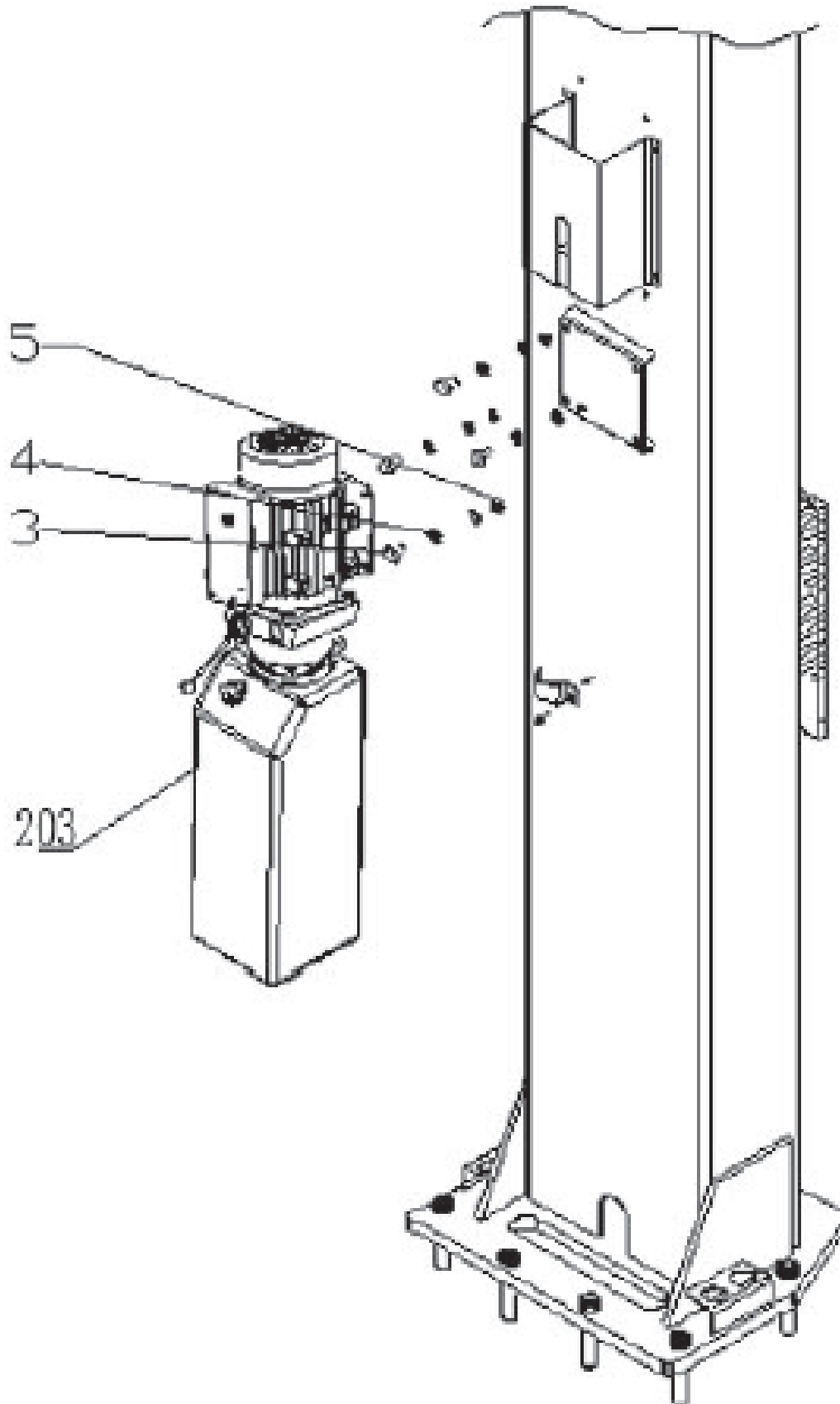

# Install hydraulic hoses

## N. Install oil hoses.

1. At high setting and low setting oil hose connection.
2. Special low setting oil hose connection.

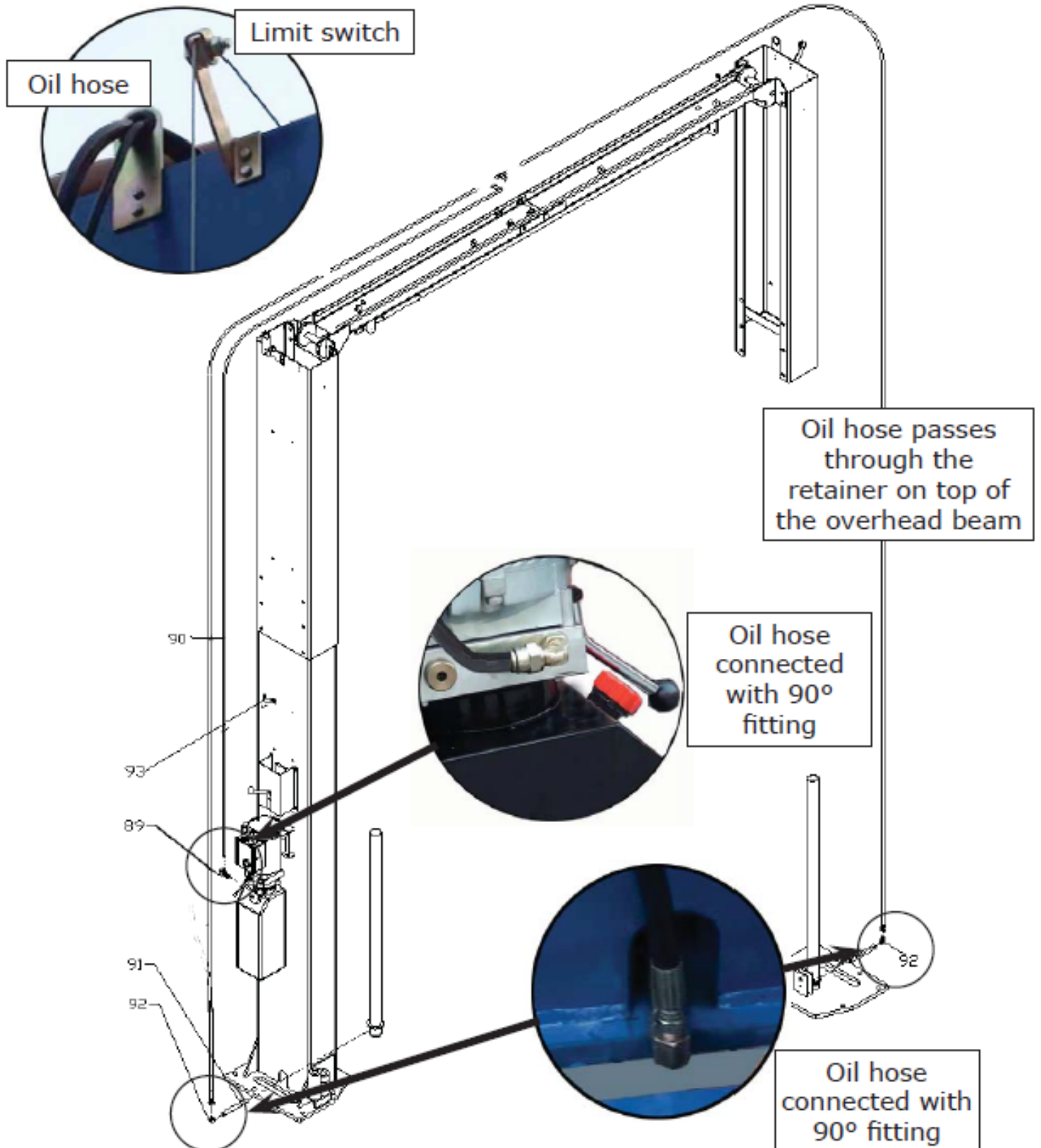

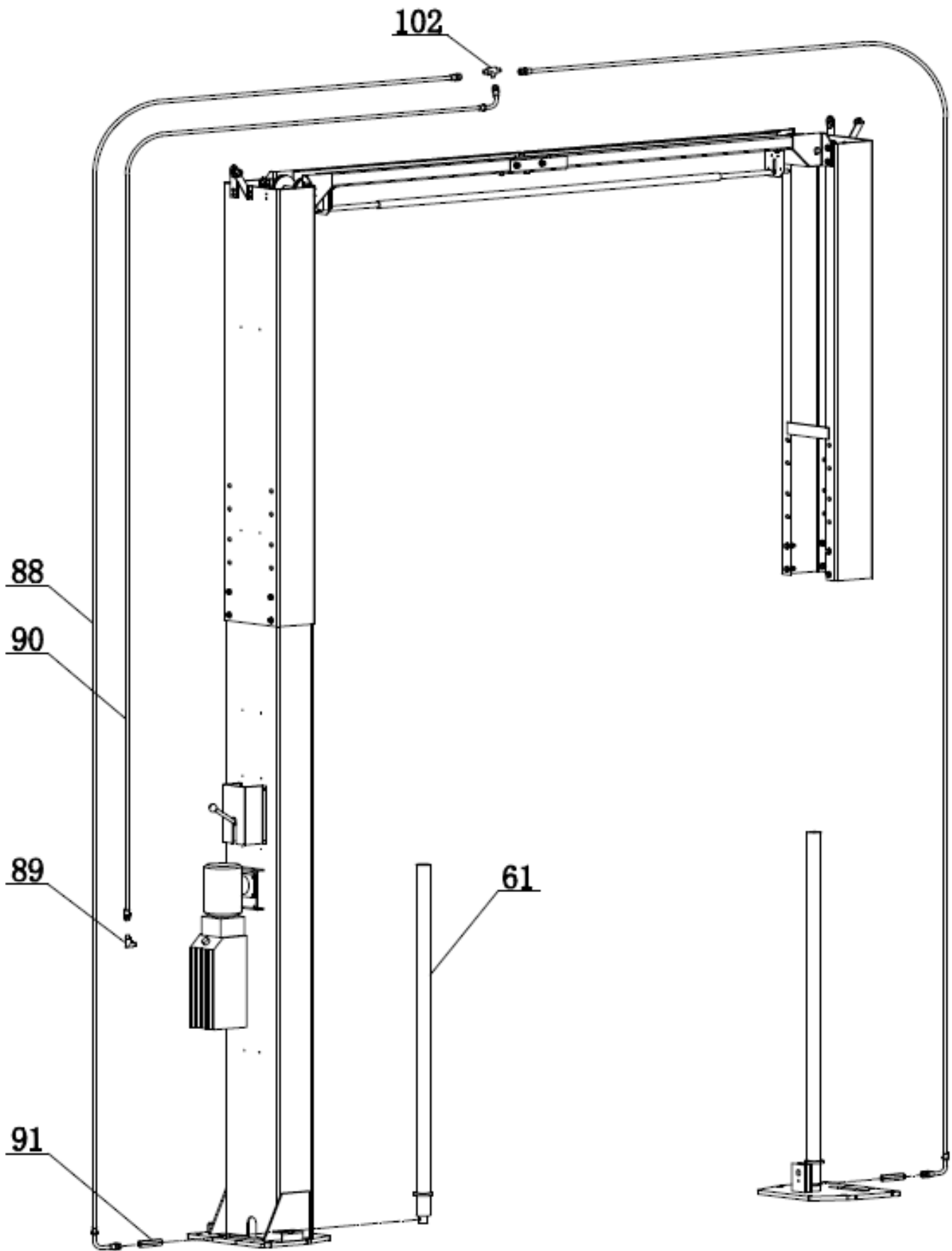

## Safety Cable Install

Install the safety cable from the off side safety assembly to the power side safety assembly (See Fig. 34).

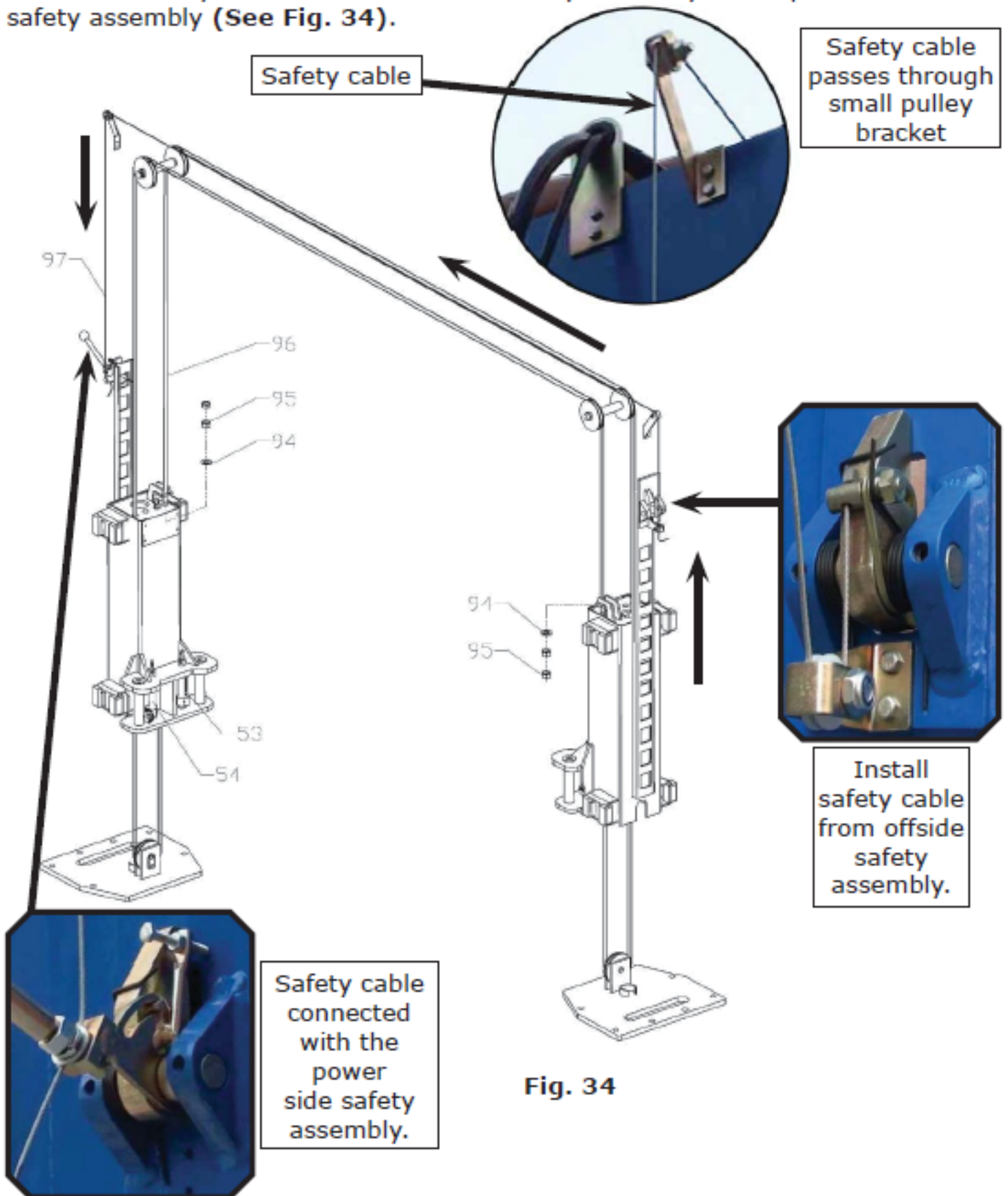

## Install hose retainers .

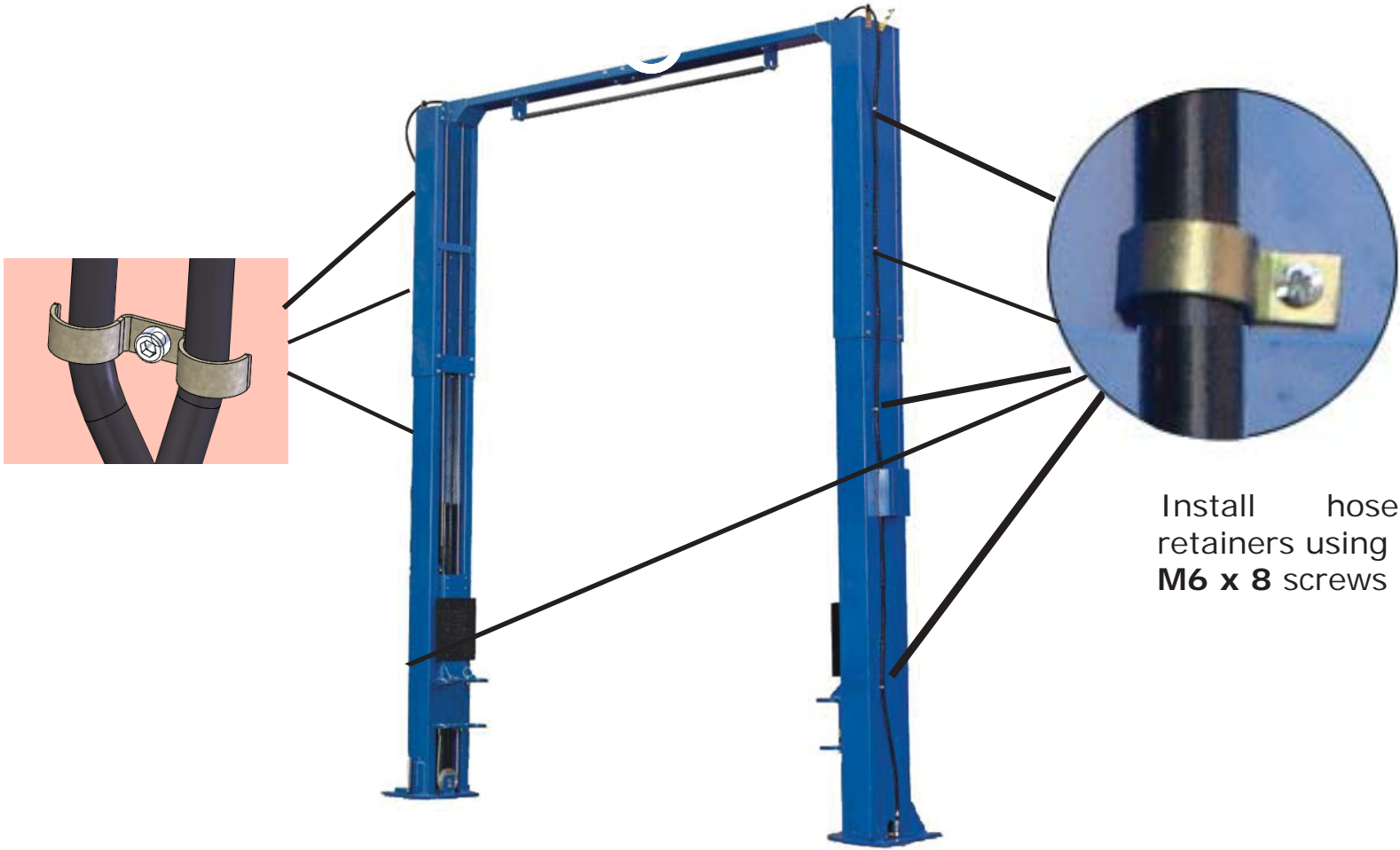

Install hose retainers using **M6 x 8** screws

## Install the lifting arms

Lower the carriages down to the lowest position, then use the 8mm Allen head wrench to loosen the socket bolt . Adjust arm lock as direction of arrow . Adjust the moon gear and arm lock so they mesh, then tighten the Allen bolts on the arm lock .

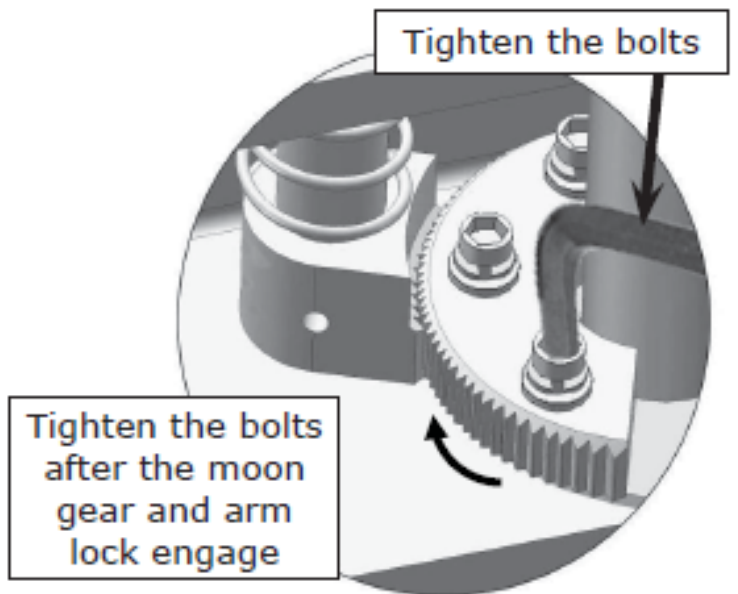
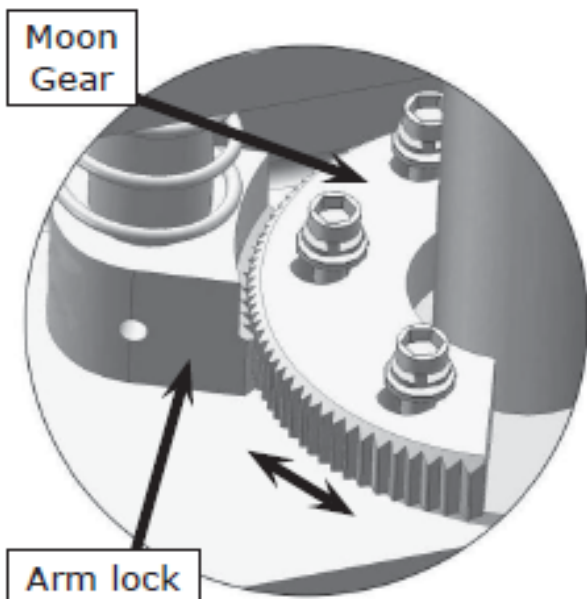
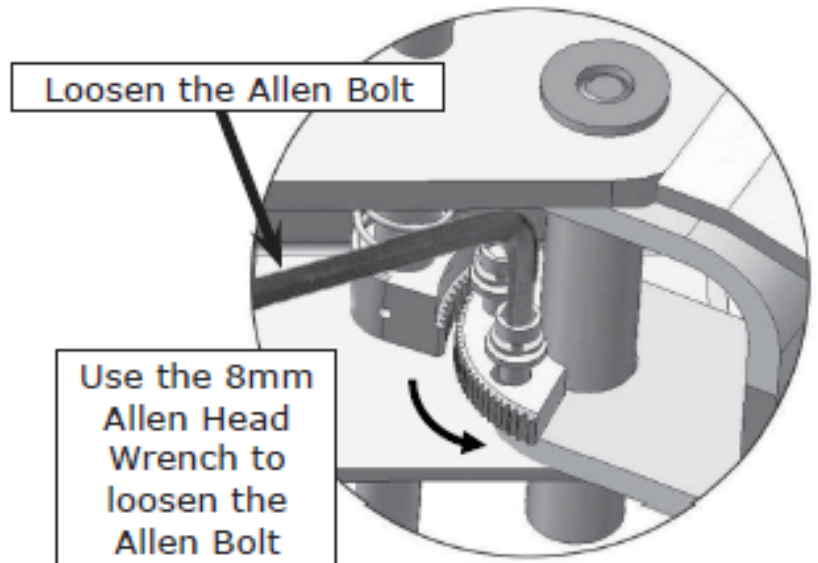
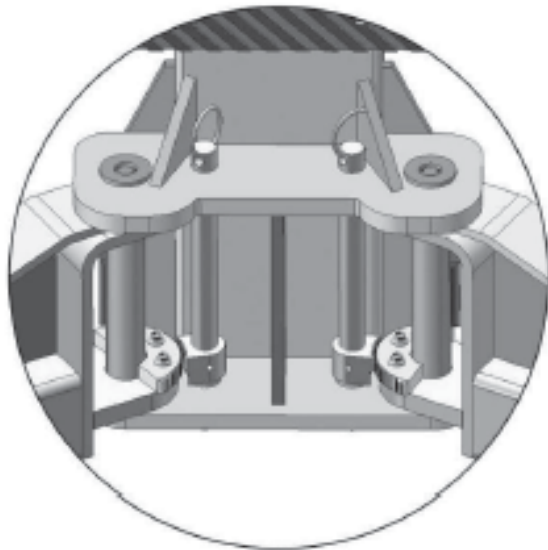

# Install Electrical System

Connect the power source according to the data plate on the Power Unit.

**Remove the short "Pig Tail" wire connected to the AC contactor terminals. This wire was used to test the motor after production.**

## ATLAS Single phase motor

### Four Terminal Relay

#### 1) Motor Lead

- a) M1 to "YELLOW"
- b) M2 to "BLUE"

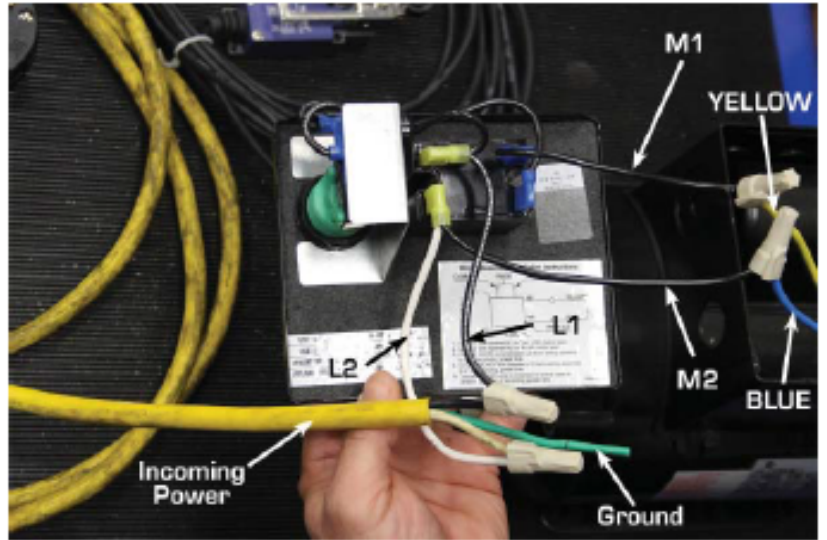

#### 2) Incoming Power

- a) One hot to L1
- b) One hot to L2
- c) Ground to ground

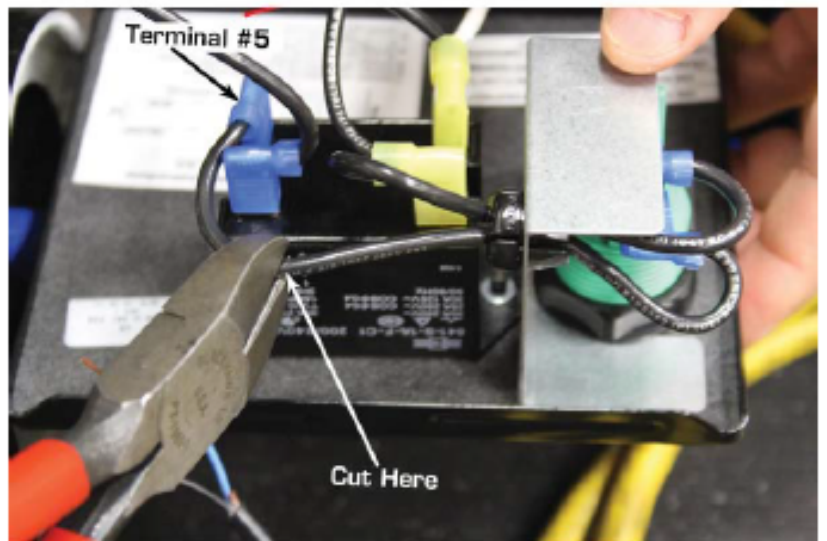

#### 3) Limit Switch

- a) Cut wire from terminal #5 to the micro switch
- b) With cut wire use both limit switch leads to make pigtails

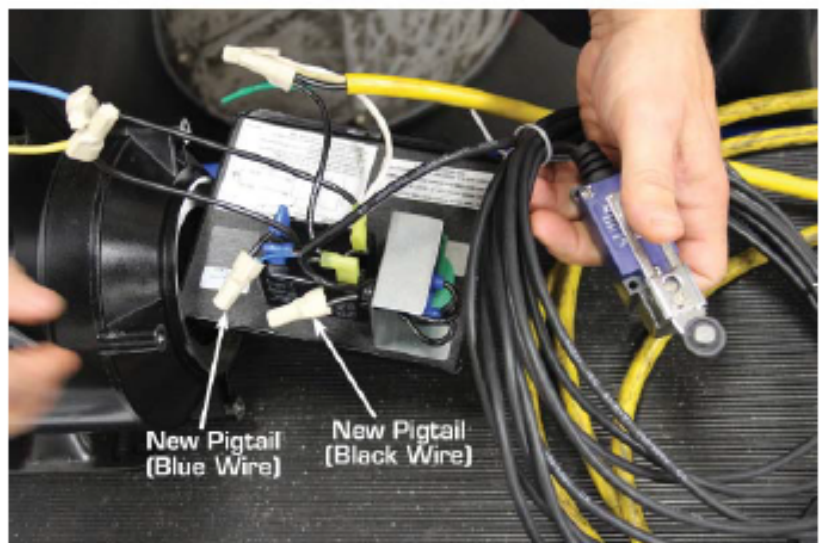

## PRE-OPERATION

### RAISING THE LIFT FOR THE FIRST TIME

1. Raise the lift, full stroke, at least twice, carefully watching and listening for any noise, binding, clunking, etc. to ensure smooth operation.
2. Load and raise the lift to full height, at least twice, with a typical vehicle being lifted at this site. Carefully watch and listen for any noise, binding, clunking, etc. to ensure smooth operation.
3. This lift is designed to raise typical vehicles, that is to say normal cars and light trucks, SUVs, etc.. It is not designed to lift over-sized vehicles like limousines, cube vans, RVs. Do not attempt to raise vehicles that are over weight or exceed the designed/advertised capacity of the lift.

## OPERATION

1. Read and understand safety items in this manual.
2. Always lift a vehicle using the manufacturers lifting points.
3. Position vehicle centered between columns such that the center of gravity of the vehicle is back of column center line 29 inches .
4. Adjust the swing arms to the vehicle manufactures lift points. Refer to the ANSI standard Vehicle Lift Points for Service Garage Lifting ANSI/SAE J2184-Oct92 for proper positioning of the arms to the vehicle.
5. Use pad extensions if needed to keep vehicle level.
6. Raise lift by pushing button on the power pack until the pad contacts the vehicle. Check to see if all pads contact the vehicle at about the same time and are making contact at the recommended lift points. Lower lift and re-adjust swing arms if needed. See action #5 (above) if a large difference in contact is seen.
7. Raise the vehicle a small amount and check to ensure the vehicle is secure on the lift pads and that the vehicle is balanced.
8. Raise vehicle to the work height by pushing button on the power pack.
9. Lower onto safety stops by pushing the release lever on the power pack.
10. **Always lower the lift onto the safety stops before working on, under or near the vehicle.**

## LOWERING THE LIFT

1. Ensure the area under the vehicle is clear of equipment, tools, personnel or other objects that may interfere with the vehicle when on the ground.
2. Raise the lift a small amount by pushing button on the power unit to clear the safety stops.
3. Release the safety locks.
4. Lower the vehicle by pushing the release lever on the power unit.
5. When lift is fully lowered, swing lift arms out from under the vehicle and remove pads and

the vehicle is balanced.

8. Raise vehicle to the work height by pushing button on the power pack.
9. Lower onto safety stops by pushing the release lever on the power pack.
10. **Always lower the lift onto the safety stops before working on, under or near the vehicle.**

### LOWERING THE LIFT

1. Ensure the area under the vehicle is clear of equipment, tools, personnel or other objects that may interfere with the vehicle when on the ground.
2. Raise the lift a small amount by pushing button on the power unit to clear the safety stops.
3. Release the safety locks.
4. Lower the vehicle by pushing the release lever on the power unit.
5. When lift is fully lowered, swing lift arms out from under the vehicle and remove pads and extensions if used.

Never drive over the lift arms or pads. Ensure the position of arms allows for the unobstructed exit of the vehicle.

### SAFETY PROCEDURES

- Never allow unauthorized persons to operate lift. Thoroughly train new employees in the use and care of lift.
- CAUTION: The power unit operates at high pressure.
- Remove passengers before raising vehicle.
- If any problems are seen with the lift, do not use it until the problem(s) are fixed.
- Prohibit unauthorized persons from being in shop area while lift is in use.
- Total lift capacity is 12000 lbs. with 3000 lbs. per arm pad.
- Check the trunk or other storage areas for loads that would affect the vehicle balance.
- Prior to lifting vehicle, walk around the lift and check for any objects that might interfere with the operation of lift and safety latches: tools, air hoses, shop equipment.
- When approaching the lift with a vehicle, center the vehicle between the columns so that the tires will clear the swing arms easily. Slowly drive the vehicle up between the posts. Have someone outside the vehicle guide the driver.
- Always lift vehicle using all four arms.
- Always ensure safety stops are engaged before any attempt is made to work on, under, or near the vehicle.
- Never use lift to raise one end or one side of vehicle.
- Raise vehicles about 36" (914mm) and check stability by rocking.
- Prior to lowering vehicle, walk around the lift and check for any objects that might interfere with the operation of lift and safety latches; tools, air hoses, shop equipment. Swing the arms out of the path and slowly drive the vehicle out. Have someone outside the vehicle guide the driver.
- 

**ALWAYS LOCK THE LIFT BEFORE GOING UNDER THE VEHICLE.**

**NEVER ALLOW ANYONE TO GO UNDER THE LIFT WHEN RAISING OR LOWERING.**

## MAINTENANCE SCHEDULE

**WARNING: USERS SHOULD ALWAYS INSPECT LIFTING EQUIPMENT AT THE START OF EVERY SHIFT. THESE AND OTHER PERIODIC INSPECTIONS ARE THE RESPONSIBILITY OF THE USER.**

Before any maintenance or inspection is performed, minimum safety requirements covering LOCKOUT/TAGOUT of all energy sources for personal safety.

Remember that this means all energy: air, gravity (raised lift), hydraulic, electrical, etc. must be **securely locked out**. LOCKOUT/TAGOUT is an requirement of OSHA/NIOSH to ensure worker safety.

*Practice good housekeeping.* Keep the area around the lift clean and free of obstacles to provide access and to avoid interference with the function or safe operation of the lift. Keep emergency paths clear.

Establish routine periodic inspections of the entire conveyor to ensure continuous maximum operating condition.

Before working on or inspecting the lift, proceed as follows:

1. Lower the lift fully.
2. LOCKOUT and TAGOUT all stored energy including electrical power and hydraulic pressure.
3. If parts are being removed, release tension from the synchronizing cables before removing any parts. See Installation Step Five - Connecting the Synchronizing Cables.

### DAILY MAINTENANCE

(Performed by the owner/operator)

1. Walk around the lift at the start of each shift. Look for damaged or bent parts on the lift, oil leaks and damaged concrete around the floor anchors or any thing else that may interfere with the safe operation of the lift.
2. Raise the lift about 12 inches check for safe operation of swing arm restraints. Look for vibration or bouncing when lifting. If seen go to trouble shooting chart.
3. Lower lift to ground, and continue use, only if no malfunctions were found.

### MONTHLY MAINTENANCE

(Performed by the owner/operator)

1. Raise lift to mid-point of travel and lower onto safety stops.
2. Check both safeties are fully engaged and functioning correctly.
3. Disconnect from electrical power. Ensure the lift control cannot be re-energized according to lockout/tag-out procedures.
4. Check all cable connections, bolts, pins, lift pads and pad extensions to ensure proper fit and tightness. Replace or repair as needed. If excess looseness in arm pivot pins is seen, lift has been overloaded and is unsafe. Stop using the lift.
5. Check for equal tension on synchronizing cables and adjust as needed. (See Installation instructions Step Five – Connecting the Synchronizing Cables points seven and eight.) Also check the cable over the full length for kinks, bends or other permanent deformation or damage. If any is found, stop using the lift.
6. Lubricate inside columns with EP-2 Grease.

7. Lubricate cables with a light penetrating oil.
8. Lubricate the pulley shafts with oil.
9. While raising the lift, check overhead cutoff switch for proper operation.
10. Check all anchor bolts for tightness and tighten if needed.

## **ANNUAL MAINTENANCE**

(Performed by the trained lift service personnel only.)

1. Follow steps 1 to 5 (inclusive) of Monthly Maintenance, detailed above.
2. Using a vernier caliper or micrometer, check the diameter of the cable 24" below the carriage and 24" above the carriage. The diameter of the cable should be no less than .367" (9.31mm) or more than .421" (1069mm).
3. Check the cable over the full length for kinks, bends or other permanent deformation or damage. Also check the flats on the outer strands of the cable. If the flats are larger in any one area, verify the cable diameter is not outside the dimensions listed above. If any damage to the cable is noted or the measurements are out of spec, stop using the lift and have it repaired before further use.
4. Continue with Monthly Maintenance Step 6.
5. Check columns for alignment and plumbness. Re-shim as required.
6. Check all anchor bolts for tightness. Tighten if needed.

**For all other maintenance, if any deficiencies are noted, or any parts need to be replaced, please contact a qualified repair contractor or Eagle Equipment at 800.336.2776.**

Broken or damaged parts must be replaced only with genuine OEM parts available from Eagle Equipment.

## TROUBLE SHOOTING

Problem	Possible Cause	Possible Solution	Instructions
Motor does not run	<ul style="list-style-type: none"> <li>- Check Fuse or circuit breaker</li> <li>- Check for correct voltage to motor</li> <li>- Inspect all wiring connections</li> <li>- Limit switch is broken or stuck</li> <li>- Push button jammed or broken</li> <li>- Motor overload tripped</li> <li>- Motor winding burned out</li> </ul>	<ul style="list-style-type: none"> <li>- Replace fuse or reset breaker</li> <li>- Supply correct voltage to motor when under load</li> <li>- Repair and insulate all connections</li> <li>- Replace switch or repair actuator</li> <li>- Replace push button</li> <li>- Reset motor overload</li> <li>- Replace motor</li> </ul>	<ul style="list-style-type: none"> <li>- Voltage drop should not exceed 3% when under load</li> <li>- Look for broken wires or loose connector screws</li> <li>- Actuator must move freely, check for bent parts</li> </ul>
Motor runs but will not raise unloaded lift	<ul style="list-style-type: none"> <li>- Low oil level</li> <li>- Open lower valve</li> <li>- Pump is sucking air</li> <li>- Motor is running in reverse</li> <li>- Relief valve is stuck open</li> </ul>	<ul style="list-style-type: none"> <li>- Fill with proper oil</li> <li>- Check or Clean Lowering Valve</li> <li>- Suction line in reservoir loose</li> <li>- Reverse leads inside motor</li> <li>- Clean or replace valve</li> </ul>	<ul style="list-style-type: none"> <li>- Lower lift to bottom, oil level should be at the bottom of the filler</li> <li>- Release handle should move freely and lowering button should move in &amp; out easily</li> <li>- Tighten suction line and check suction screen is clean</li> <li>- Check the internal wiring or return pump for replacement</li> <li>- This is a safety device, preset at the factory, disassembly could result in personal injury or death</li> </ul>

## TROUBLE SHOOTING

<b>Problem</b>	<b>Possible Cause</b>	<b>Possible Solution</b>	<b>Instructions</b>
Lift raises unloaded but not when loaded	<ul style="list-style-type: none"> <li>- Dirt in lowering valve</li> <li>- Relief valve dirty or out of adjustment</li> <li>- Lift overloaded</li> <li>- Low Voltage when running loaded</li> </ul>	<ul style="list-style-type: none"> <li>- Clean or repair lowering valve</li> <li>- Clean or replace valve</li> <li>- Reduce load or re-balance load</li> <li>- Increase voltage when under load</li> </ul>	<ul style="list-style-type: none"> <li>- Release handle should move freely and lowering button should move in &amp; out easily</li> <li>- This is a safety device, preset at the factory, disassembly could result in personal injury or death</li> <li>- An unbalanced load can cause excess friction, when close to capacity lift may overload early</li> <li>- There should be no more than 3% voltage drop from fuse/breaker to the lift when under load</li> </ul>
Lift will not stay up or settles slowly	<ul style="list-style-type: none"> <li>- Dirt in check valve</li> <li>- Dirt in lowering valve</li> <li>- External Oil Leak</li> </ul>	<ul style="list-style-type: none"> <li>- Clean check valve at oil outlet from pump</li> <li>- Clean lowering valve</li> <li>- Fix oil leaks</li> </ul>	<ul style="list-style-type: none"> <li>- Check valve prevents oil return through pump</li> <li>- Tighten fittings or replace leaking hose &amp; pipes</li> </ul>
Slow lifting or lowering speed or oil leaking from filler cap	<ul style="list-style-type: none"> <li>- Air mixed with oil</li> <li>- Clogged suction screen</li> <li>- Incorrect oil viscosity</li> <li>- Pinched hydraulic hose or line</li> </ul>	<ul style="list-style-type: none"> <li>- Leak in suction line</li> <li>- Clean suction filter or screen</li> <li>- Change oil to a different grade</li> <li>- Inspect all line and hoses for visual damage</li> </ul>	<ul style="list-style-type: none"> <li>- Inside reservoir</li> <li>- Inside reservoir</li> <li>- See the chart following this table</li> <li>- Look for kinks or nicks, hose can balloon the inside lining. This is very difficult to find if all else fails replace all hoses</li> </ul>

## TROUBLE SHOOTING

<b>Problem</b>	<b>Possible Cause</b>	<b>Possible Solution</b>	<b>Instructions</b>
Lift raising unevenly	<ul style="list-style-type: none"> <li>- Synchronizing cables out of adjustment</li> <li>- Lift installed unevenly on the floor</li> </ul>	<ul style="list-style-type: none"> <li>- Tension cables correctly</li> <li>- Shim low column, max 1/2" off the floor</li> </ul>	<ul style="list-style-type: none"> <li>- See text in this manual</li> <li>- If more than 1/2" shim is needed, the floor will have to be repaired or the lift moved.</li> </ul>
Anchors keep loosening	<ul style="list-style-type: none"> <li>- Holes are over sized</li> <li>- Concrete floor thin or not strong enough</li> </ul>	<ul style="list-style-type: none"> <li>- Reset anchors</li> <li>- Break up floor and replace concrete</li> </ul>	<ul style="list-style-type: none"> <li>- Remove each bolt and fill hole with a fast setting epoxy concrete repair re-drill hole with new drill</li> <li>- Test a core to see if floor is 3000psi and check thickness as well</li> </ul>
Safety locks not engaging	<ul style="list-style-type: none"> <li>- Lock dog sticking</li> <li>- Lock dog return spring broken</li> <li>- Bent or damaged mounting bracket</li> <li>- Release cable out of adjustment</li> </ul>	<ul style="list-style-type: none"> <li>- Lubricate both lock dogs under the side covers</li> <li>- Replace spring</li> <li>- Repair mounting bracket or pivot pin</li> <li>- Adjust release cable</li> </ul>	<ul style="list-style-type: none"> <li>- Lubricate both sides</li> <li>- Check both sides</li> <li>- Do not heat or weld to column, the heat will weaken the steel</li> <li>- See text in this manual</li> </ul>
Lift becomes inoperative with vehicle in raised position	<ul style="list-style-type: none"> <li>- Burst hydraulic line or fitting</li> <li>- Low hydraulic fluid level</li> <li>- Defective hydraulic cylinder</li> <li>- Other</li> </ul>	<ul style="list-style-type: none"> <li>- Clear all personnel and equipment near the lift</li> <li>- Contact a local wrecker service that can provide a rollback truck</li> <li>- Contact Eagle Equipment for replacement parts</li> </ul>	<ul style="list-style-type: none"> <li>- Remember SAFETY FIRST.</li> <li>- The rollback truck should support the vehicle and prevent it from dropping.</li> <li>- Extreme cases may require a forklift. This can damage vehicle undercarriages.</li> </ul>

**SPECIFICATIONS**

12 K		
Style	Symmetric	
Max Lifting Height	72.5" - 78.5"	
Total Width (outside baseplate)	157"	
Drive-Through Clearance	109.8"	
Floor to Overhead Switch	167.9"	
Arm Reach (min/max)	37.8" - 57.7"	Three stage arm
Drop-in Pad Height	4.5"	
Inside Column Width	123.7"	
Motor	2.5HP	
Voltage	208-230 volt / 1 phase	
Rise	55 seconds	
Max Load per Arm	3000 lbs	
Minimum Ceiling Height Req.	13'	
Maximum Column Height	176.9"	

# Installation Height Options

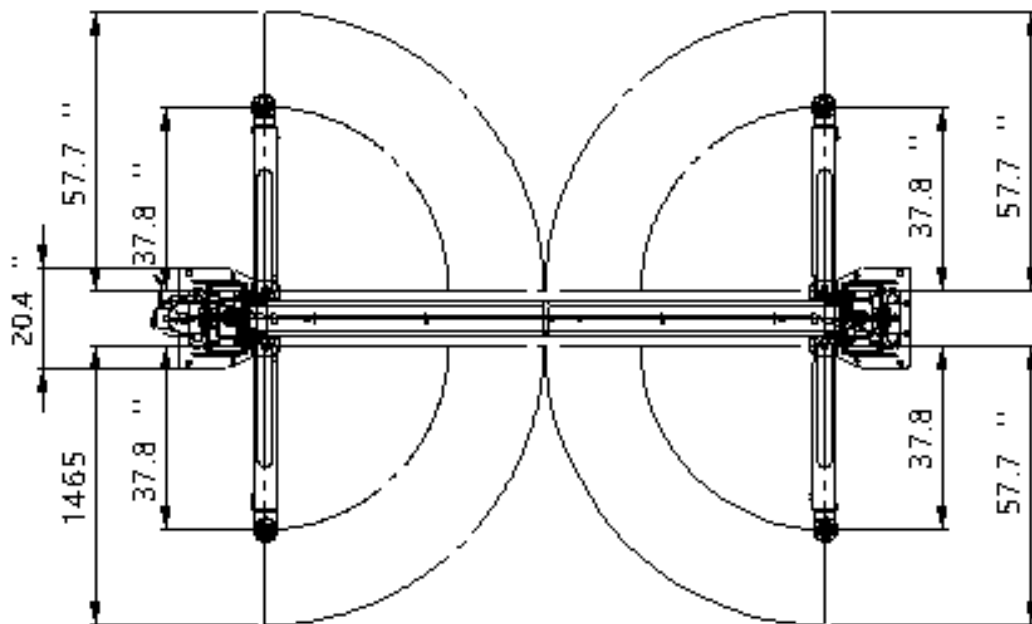
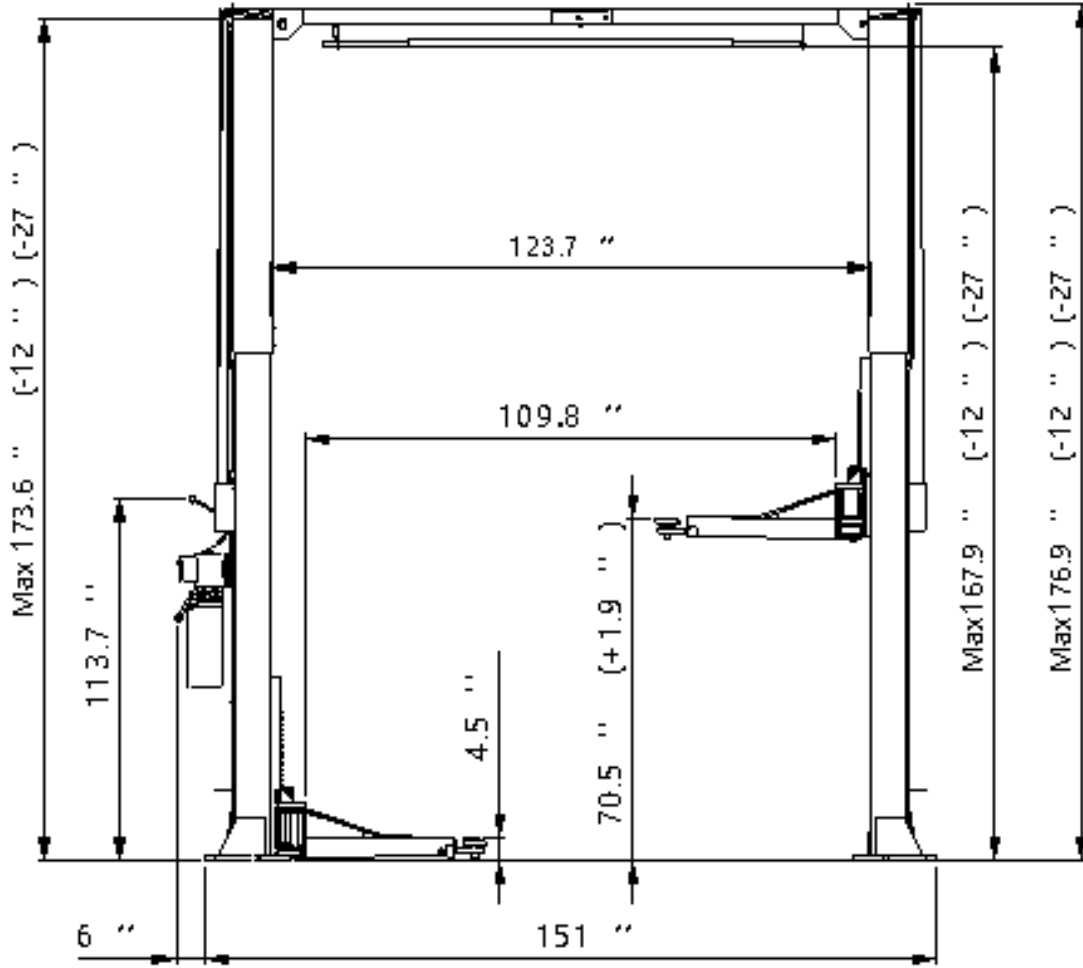

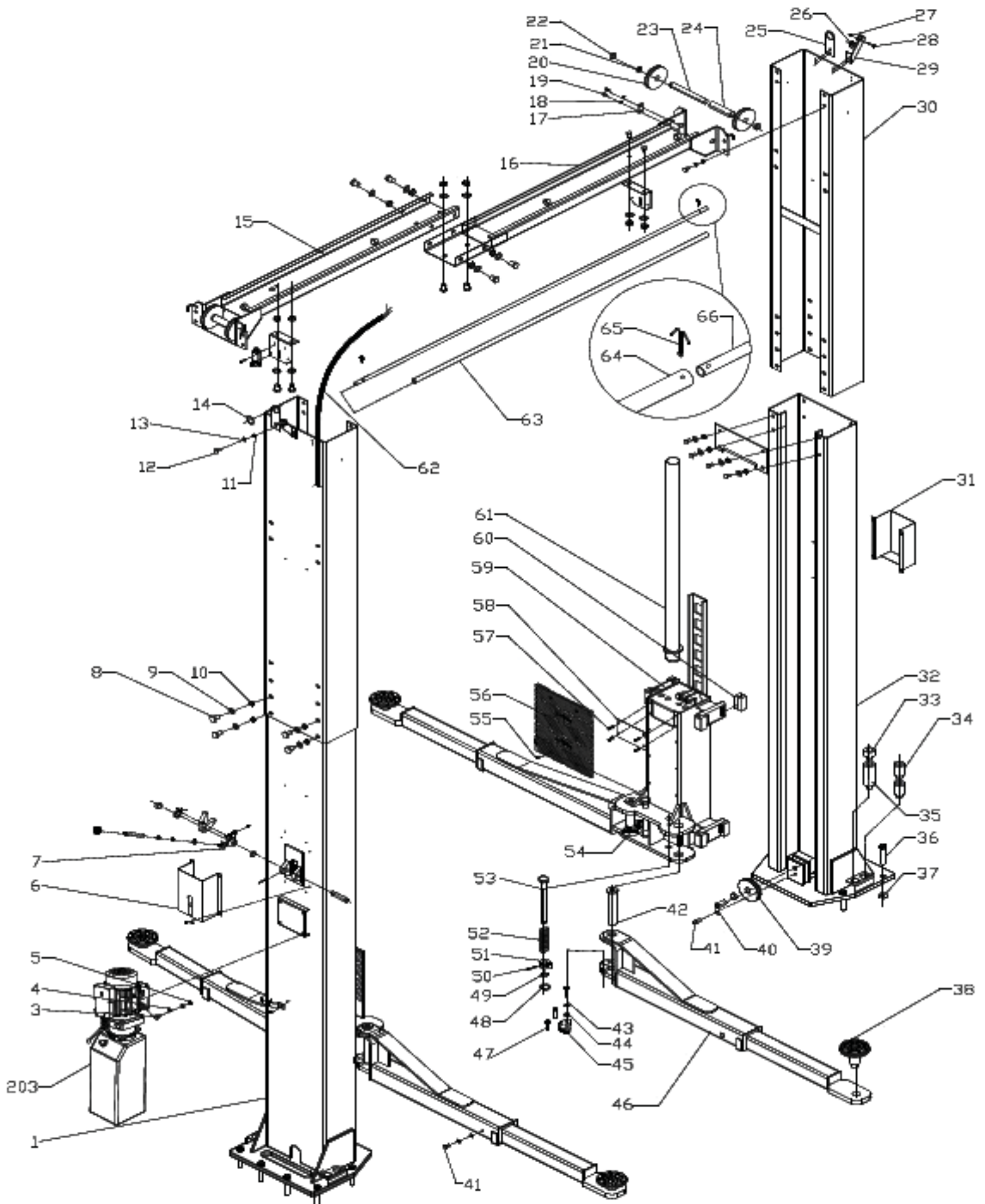

## Parts List

EAG-12			
Item	Part#	Description	Qty
1	PV12-1100A	Powerside column	1
203		Power unlt	1
3	GB5780-2000-M8×25	Hex Bolt M8×25	4
4	GB97.1-2002-8	Washer φ8	10
5	GB41-2000-8	Hex Nut M8	4
6	30500-8000-1A	Powerside lock cover	1
7	30500-5001(B)-26G1	Main cam lock	1
8	GB5780-2000-M12×30	Hex Bolt M12×30	34
9	GB97.1-2002-12	Washer φ12	34
10	GB6184-2000-12	Self locking nut M12	34
11	GB6184-2000-6	Self locking nut M6	8
12	GB5780-2000-M6×20	Hex Bolt M6×20	8
13	GB97.1-2002-6	Washer φ6	24
14	PV10-4402	Protective ring	2
15	PV12-3200	Overhead bar B	1
16	PV12-3100	Overhead bar A	1
17	PV10-3001	Pin stop	2
18	GB93-87-8	Lock washer φ8	10
19	GB70.1-2000-M8×16	Socket Bolt M8×16	4
20	BP-2002	Top pulley	4
21	52004A	Bronze bush for pulley	6
22	OH-4102	Top pulley spacer	4
23	PV10-3002	Pin	2
24	PV10-3003	Pin spacer	2
25	PV10-4401	Hose support	2
26	30500-8000-2-2	Plastic small pulley	3
27	GB91-2000-2×16	Split pin φ2×16	3
28	GB882-86-B6×35	Pin B φ6×35	3
29	30500-8000-2	Safety cable bracket	2
30	PV12-2000	Extension column	2
31	30500-8000-1B	Offside lock cover	1
32	PV12-1100B	Offside column	1
33	30400-6014AG	Adapter	4
34	PV10-4002	Adapter	4

## Parts List

35	30400-6015AG	Adapter	4
36	PZ-3/4"×7"	Expansion bolt 3/4-10*7"	12
37	30400-1025	Plastic gasket	10
38	PV10-4300	Rubber pad assy.	4
39	PV10-1001	Bottom pulley	2
40	PV10-1200	Bottom pin	2
41A	GB5780-2000-M8×16	Hex Bolt M8×16	2
41	GB5780-2000-M10×16	Hex Bolt M10×16	4
42	PV12-4200	Arm pin	4
42A	GB894.1-86-38	Snap ring $\phi$ 38	4
43		Lock washer 10mm	12
44	GB97.1-2002-10	Washer $\phi$ 10	17
45	PV10-6001	Moon gear	4
46	PV12-6000	Lifting arm	4
47	GB70.1-2000-M10×30	Socket bolt M10×30	12
48	GB894.1-86-25	Snap ring $\phi$ 25	4
49			
50	GB119.1-2000-6×40	Roll pin $\phi$ 6×40	4
51	PV10-5001	Arm lock	4
52	PV12-5002	Spring	4
53	PV12-5200	Left arm lock bar	2
54	PV12-5300	Right arm lock bar	2
55	GB-T819.1-2000-M6×16	Bolt M6×16	12
56	PV10-5005	Protective Rubber	2
57	GB818-2000-M6×8	Cup head bolt M6×8	18
58	PV10-5004	Carriage plastic cover	2
59	PV12-5000	Carriage	2
60	PV10-5003	Slider block	16
61	PV12-9100	Cylinder	2
62	PV12-4006	Wire cable	1
63	OH-4301	Foam Cushion	1
64	PV10-4102	Limit bar	1
65	GB91-2000-4×50	Split pin $\phi$ 4×50	2
66	PV10-4101	Limit bar link	2
67	TZ-8104	Limit switch	1
68	GB818-2000-M5×12	Cup head bolt M5×12	2

## Parts List

69	PV10-4001	Limit bar bracket	2
70	GB93-87-10	Lock washer $\phi 10$	17
71	GB41-2000-10	Hex Nut M10	1
72	M10×S $\phi$ 35	Plastic ball $\phi 35 \times M10$	1
73	30500-5001(B)-12	Lock handle	1
74	30500-5001(B)-07	Large spacer	2
75	30500-5001(B)-10	Main spring	2
76	HPRO-1010	Main lock	2
77	GB5780-2000-M6×35	Hex Bolt M6×35	1
78	GB41-2000-6	Hex Nut M6	1
79	30500-5001(B)-24	Small spacer	2
80	30500-5001(B)-09	Main lock pin	2
81	GB78-2000-M10×16	Socket bolt M10×16	2
82			
83	30500-5001(B)-25G1	Spring	1
84	30500-5001(B)-22	Cam lock	1
85	30500-5001(B)-27	Self locking nut	1
86	HPRO-5004G	Cable lock hold	1
87	30500-8000-3-1	Small pulley bracket	1
88	PV12-4003	Oil hose	2
89	30400-9053YZ	90 fitting for power unit	1
90	PV12-4004	Oil hose	1
91	PV10-4021	Extend fitting for cylinder	2
91A			
92		Combined sealing gasket	
93	30400-9056A	Retainer	10
94	GB97.1-2002-20	Cable nut washer $\phi 20$	4
95	GB6170-86	Cable nut 3/4"-16	8
96	PV12-4500	Cable 37'6.750"	2
97	PV12-4005	Safety cable	1
98	PV12-4007	Column connecting plate	2
102	SW-001	T-fitting	1



**EagleEquipment**, is a leading distributor of automotive repair and garage service equipment. Established in 1954, Eagle has provided quality equipment at competitive prices for 60 years. We carry a full line of automotive lifts: two-post lifts, four-post lifts, alignment lifts, scissor lifts, low-rise and mid-rise lifts, as well as models of movable service/storage lifts and our MOBILEMAN®. We also stock wheel service equipment including: wheel balancers, tire changers. We offer a full line of parts, as well as technical support. Visit us at [www.eagleequip.com](http://www.eagleequip.com).

---

