



MS-8000

(AND MS-8000XLT)

8,000 LBS. CAPACITY
FOUR-POST STORAGE/SERVICE LIFT

INSTALLATION & OPERATION MANUAL

***READ THIS MANUAL BEFORE INSTALLING OR
OPERATING YOUR LIFT***

REV 20151112.TIA03 BD

INSPECT YOUR LIFT UPON DELIVERY. NOTE ANY DAMAGE ON DELIVERY RECEIPT.

TABLE of CONTENTS	(page)
TRANSPORTATION	3
SHIPPING and DAMAGE CLAIMS	3
INTRODUCTION	4
MODEL and SERIAL NUMBER INFORMATION	4
IMPORTANT SAFETY INSTRUCTIONS	5
UNPACKING	6
BASIC STRUCTURE of PRODUCT	7
GENERAL PROFILE & LAYOUT	8
COMPONENTS	9
INSTALLATION - (Tools Required)	10
STEP 1: SELECTING A LOCATION	11
STEP 2: FLOOR REQUIREMENTS	12
STEP 3: COLUMN & CROSS RAIL ASSEMBLY	13-14
STEP 4: RUNWAY ASSEMBLY	15-16
STEP 5: INSTALLING THE CABLES	17-19
STEP 6: SLACK-CABLE SAFETY ROUTING	18
STEP 7: INSTALLING THE CABLES (Cont.)	18-19
STEP 8: INSTALLING THE POWER UNIT	20
STEP 9: INSTALLING HYDRAULIC FITTINGS	21
STEP 10: INSTALLING THE HOSES	22
STEP 11: START-UP	23
WIRING THE LIFT	24
PRIMING THE POWER UNIT	25
STEP 12: LINKAGE AND LOCK RODS	26
STEP 13: ADJUSTING THE CABLES	27
STEP 14: WHEEL STOPS AND RAMPS	28
STEP 15: THE CASTER KIT	29
STEP 16: SECURING THE POSTS (OPTIONAL)	30-31
OPERATION	32
RAISING A VEHICLE	32
LOWERING A VEHICLE	32
MAINTENANCE	33
TROUBLE-SHOOTING	34
PARTS-LIST	35-39
MAIN STRUCTURE	35
SUB-STRUCTURE	36-37
PART-NUMBERS	38-39
WARRANTY INFORMATION	42

TRANSPORTATION

All shipments are F.O.B Greensboro and become the property of the customer when they leave our dock. Eagle Equipment uses common carriers (Fed-Ex Ground, UPS, etc.) and independent freight haulers for shipping. We negotiate the most competitive freight rates possible and pass these savings along to our customers. And we make every effort to minimize freight charges and provide a timely delivery for our customers. We cannot advise customers of exact time-of-delivery. We can provide an Estimated Time of Arrival (ETA), and tracking information.

Customer is responsible for unloading the lift. Eagle Equipment assumes no responsibility for any additional charges due to delayed delivery, or damages that may be incurred unloading product from the delivering carrier's truck. Freight carriers may have restrictions on deliveries to residential addresses and may require pick-up at a freight terminal.

An automotive lift is a heavy piece of equipment. A fork-lift or other similar mechanism is necessary for its loading, off-loading and movement. (Lifts cannot be unloaded with a lift-gate.) Upon arrival, customer is responsible for unloading and receiving the lift from the freight carrier. Customer's site must be accessible to the freight carrier.



INSPECT YOUR LIFT UPON DELIVERY.
NOTE ANY DAMAGE ON DELIVERY RECEIPT.



SHIPPING AND DAMAGE CLAIMS

All shipments must be inspected immediately upon receipt. For your protection, any external damage must be noted on the Bill of Lading at the time of delivery in order to qualify for a claim against the freight carrier.

Concealed damage must be reported to the freight company within three (3) days of delivery. It is the customer's responsibility to file for damage claims against the freight company. Eagle Equipment is not responsible for loss or damages caused by shipping.

Shortages or missing parts must be reported to **Eagle Equipment Customer Service** (1-800-336-2776) within three (3) days of delivery.

INTRODUCTION

Thank you for your purchase.

Your lift is the result of decades of research, testing and development; and represents the most advanced technology on the market.

The care with which you maintain and operate your lift will directly affect its overall performance and longevity.

BE SAFE

Your lift was designed and built with safety in mind. However, safety relies on proper training and thoughtful use on the part of the operator. **DO NOT** operate or repair this equipment without reading this manual and the important safety instructions shown inside.

Keep these instructions accessible, and make sure that ALL USERS read this manual.



READ THIS ENTIRE MANUAL
CAREFULLY AND COMPLETELY
BEFORE INSTALLATION
OR OPERATION OF THE LIFT.



RECORD THE MODEL NUMBER AND THE SERIAL NUMBER

(LOCATED ON THE MAIN POST OF YOUR LIFT)

Model Number: _____

Serial Number: _____

Manufacturing date: _____

THIS INFORMATION WILL BE REQUIRED
SHOULD YOU EVER NEED TO CALL IN
FOR PARTS OR TECHNICAL ASSISTANCE.

For assistance, please call: 1-800-535-0016

IMPORTANT SAFETY INSTRUCTIONS

Read These Safety Instructions Thoroughly

1. Read and understand all operation & safety warning procedures before operating lift.
2. Keep hands and feet clear. Remove hands and feet from any moving parts. Keep feet clear of lift when lowering. Avoid pinch points.
3. Keep work area clean. Cluttered work areas invite injuries.
4. Consider work area environment. Do not expose equipment to rain. Do not use in damp or wet locations. Keep area well lighted.
5. Only trained personnel should operate this lift. All non-trained personnel should be kept away from the work area. Never let non-trained personnel come in contact with, or operate lift.
6. Use lift correctly. Use lift in the proper manner. Never use lifting adapters other than those provided by the manufacturer, in any manner other than intended.
7. Do not override self-closing controls.
8. Remain clear of lift when raising or lowering vehicle.
9. Clear area if vehicle is in danger of falling.
10. Always insure that the safeties are engaged before any attempt is made to work on or near vehicle.
11. Dress properly. Non-skid, steel-toe foot-wear is recommended when operating lift.
12. Carefully inspect the lift on a regular basis. Perform maintenance according to the maintenance schedule.
12. Guard against electric shock. This lift must be grounded while in use to protect the operator from electric shock. Never connect the ground wire to a live terminal. This is for ground only.
13. **Danger!** The power unit used on this lift contains high voltage. Disconnect power at the receptacle before performing any electrical repairs. Secure plug so that it cannot be accidentally plugged in during service.
14. **Warning!** Risk of explosion. This equipment has internal arcing or sparking parts which should not be exposed to flammable vapors. This machine should not be located in a recessed area or below floor level.
15. Maintain with care. Keep lift clean for better and safe performance. Follow manual for proper lubrication and maintenance instructions. Keep control handles and/or buttons dry, clean and free from grease and oil.
16. Stay alert. Watch what you are doing. Use common sense. Be aware.
17. Check for damaged parts. Check alignment of moving parts, breakage of parts or any condition that may affect its operation. Do not use lift if any component is broken or damaged.
18. Never remove safety related components from the lift. Do not use the lift if safety related components are damaged or missing.

UNPACKING



WARNING Failure to follow the Unpacking and Assembly Directions **WARNING**
may cause personal injury and/or impair the operation of this machine.

Please read thoroughly.



- 1] Your lift comes packaged as a single unit (Fig. 1). A fork-lift, floor-jack or other heavy-lifting equipment may be necessary to separate the components. Exercise caution when disassembling the packaged lift, as shifting may have occurred during shipping.
- 2] Carefully remove the shipping bands and brackets from the lift. Check for any obvious shipping damage. (Remember to report any shipping damage to the carrier and make a notation on the delivery receipt.) Save all bolts, nuts and washers securing the shipping brackets, as these may be used in the assembly of the lift.
- 3] The unit is composed of several main components. (See Fig. 2, below)
- 4] An Accessory Box is included with the lift, for smaller components.
- 5] Un-strap and remove Power Unit box from packaged lift. (Literature such as the Installation Manual, Warranty Card, and Serial Number Plate is usually included inside this box.) Inspect the power unit, and note any possible shipping damage on the shipping bill.
- 6] Remove Arms from their shipping location inside towers, and set aside.

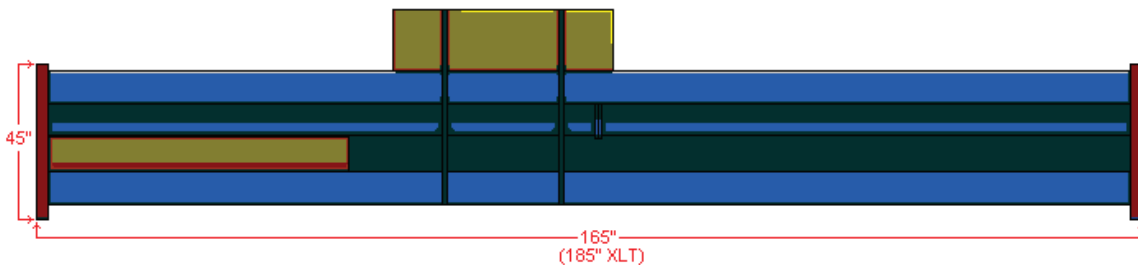

(Fig. 1)



Shipments must be inspected immediately upon receipt.



External damage must be noted on Bill-of-Lading.

Concealed damages must be reported to freight company within three days of delivery.

Shortages must be reported to Eagle Equipment within three days of delivery.

(1-800-336-2776)

BASIC STRUCTURE OF PRODUCT

This product is a four-post, single cylinder, direct-drive lift which uses steel cables for lifting and leveling. The main components are the towers, runways, ramps, cross-rails, cylinder, cables and power unit. Cross-rails have locking mechanisms for simple and safe operation.

Depressing the switch on the power unit raises the lift. Releasing the switch stops the lift. Lift should always be settled on the locking mechanisms. To lower the lift, simply raise the cross-rails up off the locks, use the single-point lock-release handle to disengage the locks, and depress the lowering handle.

Ramps drop-in and lift-out for easy application. Casters afford mobility with or without a vehicle. A jack tray is included for use with independent jacks (not included).

Model	MS-8000
Lifting Capacity	8,000 lbs.
Overall Height	86-1/4"
Overall Width (outside of base plate)	104"
Overall Length (outside of base plate)	176"
Overall Length (with Ramps)	208"
Inside Columns (Drive-Through)	93-1/2"
Track height	4-1/4"
Track width	18-1/2"
With between tracks	37"
Rise (max. clearance under track)	70"
Lift Height Max.	74-3/4"
Motor	2HP 110 or 220 VAC
Time to full rise (NO LOAD)	45 seconds (220 PU)
Shipping Weight	1,680 lbs.
Shipping Dimensions	165 " L x 20" W x 45" H

Model	MS-8000XLT
Lifting Capacity	8,000 lbs.
Overall Height	96"
Overall Width (outside of base plate)	110"
Overall Length (outside of base plate)	191"
Overall Length (with Ramps)	223"
Inside Columns (Drive-Through)	99-1/2"
Track Height	4"
Track Width	18-1/2"
With between tracks	43"
Rise (max. clearance under track)	78"
Lift Height Max.	82-1/4"
Motor	2HP 110 or 220 VAC
Time to full rise (NO LOAD)	45 seconds (220 PU)
Shipping Weight	1,914 lbs.
Shipping Dimensions	185 " L x 20" W x 45" H

PROFILE

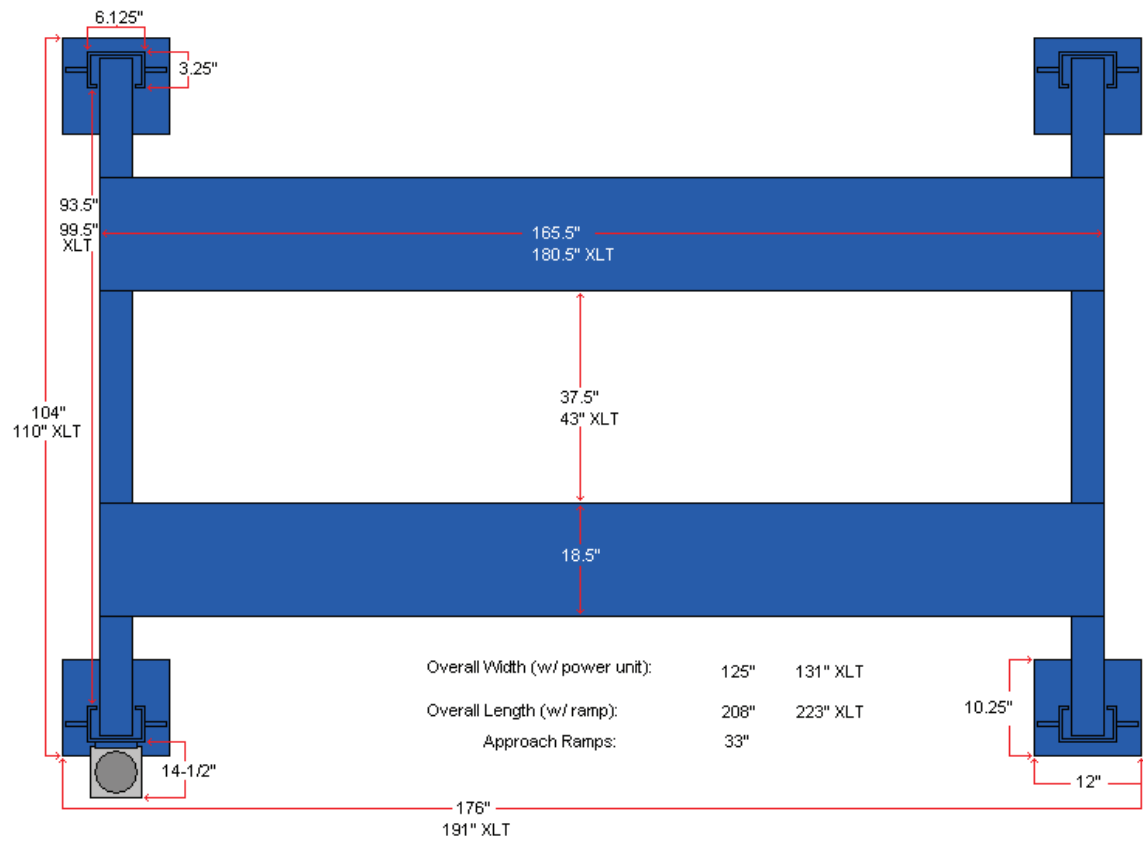

(Fig. 2)

COMPONENTS



It is a good idea to familiarize yourself with the components of your lift and the terms describing them. (Fig. 3)



(Fig. 3)

INSTALLATION



NOTE: Installation is the Customer's Responsibility.



It is the responsibility of the purchaser to ensure proper installation of this lift. Automotive lifts are pieces of heavy machinery and precision equipment, so their installation is extremely important. In preparing for the installation, it is necessary to procure the correct tools and choose the right site. Work-space, floor-strength, ceiling height & overhead clearance, and a sufficient & reliable power source should all be considered well in advance. Any questions about floor capacity should be resolved prior to beginning the installation.

A professional lift installer is suggested. Whoever installs the lift should read this manual thoroughly and familiarize themselves with its content.

A certified electrician is required for the final connection of the lift's power unit; and all local codes and requirements should be followed.

Always wear the proper clothing, safety-gear and Personal Protection Equipment (PPI) when installing or servicing this lift.

TOOLS REQUIRED

25' Measuring Tape
Chalk Line
Marker or Floor Crayon
Rotary Hammer Drill
 $\frac{3}{4}$ " (19mm) dia. Masonry Drill Bit
4lbs. Hammer
SAE Wrenches & Ratchet Set
Metric Wrenches & Ratchet Set
Torque Wrench
2' Level
4' Level
Pry Bar
12' Step Ladder
Side Cutters
Vise Grips
Screwdriver Set
4" x 4" Wooden Blocks (to assist in unpacking)
Floor-Jack or Dollies (to assist in unpacking)
4 gal. AW-32 Hydraulic Oil
Funnel
White Lithium Spray

INSTALLATION

STEP 1

Selecting the Site

Your lift requires **110v or 220v, 20amp, single phase** electrical power. The area of operation should provide the minimum space shown above (Fig. 2). There should be room enough to operate the lift in a safe manner and without restrictions. The area should be kept clean of oil, grease, etc., and clear of clutter. Avoid areas where customers or other bystanders may be present.

Before installing your lift, check the following:

1] LIFT LOCATION: Always use architect's plans when available. Check layout dimension (Fig. 2) against floor plan requirements making sure adequate space is available.

2] OVERHEAD OBSTRUCTIONS: The area where the lift will be located should be free of overhead obstructions such as heaters, building supports, electrical lines, doors, etc.

3] DEFECTIVE FLOOR: Visually inspect the site where the lift is to be installed and check for cracked or defective concrete.

4.] OPERATING TEMPERATURE: Only operate lift between temperatures of 41-104 degrees Fahrenheit.



**ATTENTION: This lift is intended for indoor installation only.
Improper installation may void your warranty
and cause damage to lift and property, and/or personal injury.**



STEP 2

Floor Requirements

Specifications of concrete must be adhered to. Failure to do so could cause lift failure resulting in personal injury or death.

A level floor is suggested for proper installation and level lifting. Small differences in floor slopes may be compensated for by proper shimming. If a floor is of questionable slope, consider a survey of the site and/or the possibility of pouring a new level concrete slab.

DO NOT install this lift on any asphalt surface or any surface other than concrete.

DO NOT install this lift on expansion seams or on cracked or defective concrete.

LIFT must be installed at least 6" from the edge of the concrete slab.

CONCRETE ANCHORS must be at least 4" from any cracks, seams, or saw cuts in the concrete.

SHIMS must be installed at all anchor points where there is a gap between the base plate and the concrete. Do not shim more than 1/2".

DO NOT install this lift on a second/elevated floor without first consulting building architect.

DO NOT install this lift outdoors. If you insist on installing this lift outside, special consideration should be made to protect the power unit from inclement weather conditions. (**Warranty does not cover damage or wear due to outside installation.**)

CONCRETE SPECIFICATIONS

LIFT MODEL

CONCRETE REQUIREMENT

MS-8000 (8,000 lbs.)

4" Minimum Thickness

MS-8000XLT (8,000 lbs.)

4" Minimum Thickness

NOTE: All models **MUST** be installed on 3,000 PSI or greater reinforced concrete; conforming to the minimum requirements shown above. New concrete must be adequately cured for at least 30 days.



ATTENTION: DO NOT ATTEMPT TO PRE-SET ANCHORS!



Anchors are designed to be inserted into holes drilled in a properly poured, cured and reinforced floor, at the time of the lift's installation.

(See STEP 15)

Attempting to pre-set anchors will unnecessarily complicate the installation process, and may compromise the integrity of lift.

STEP 3

Column & Cross Rail Assembly



DO NOT BEGIN INSTALLATION CLOSE TO A WALL.
Adequate clearance will be necessary for
Installation of linkage rods.
(Allow 40" clearance.)



- 1] Make a chalk line on the floor following the layout shown above (Fig. 2).
- 2] Determine the desired location for the **Power Unit**. This can be located at either location shown (Fig. 4).

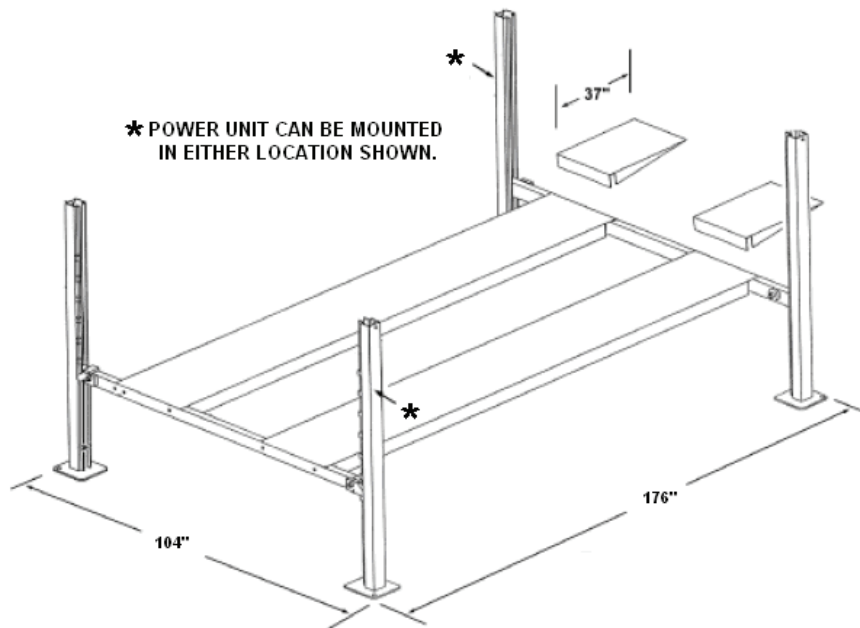

(Fig. 4)

- 3] Stand the columns in place making sure to position the power unit mounting bracket column (Main Post) at the correct location as indicated above (Fig. 4).
- 4] Install the cross rails into the posts and drop them all the way to the floor. **The Slack Cable Safety rollers will be facing towards the inside of the lift.**
- 5] Install the **Safety Lock Ladders** into the posts by sliding them in sideways and dropping them into the slots in the top of the **white guide blocks** on the Cross Rails.
- 6] Install a nut onto the top of the stud of each ladder until about 1 ½" of thread is exposed.
- 7] Install the post caps and bolts and tighten all the bolts
- 8] Lift the ladders up until the threaded studs pass through the holes in the post caps. Install nuts onto the bolts at the top of the ladders and thread down onto the bolts until about ½" of thread is exposed. (Fig. 4a)
- 9] Lift the cross rails up and lock in the **second** ladder lock position (Fig. 4b).



(Fig. 4a)

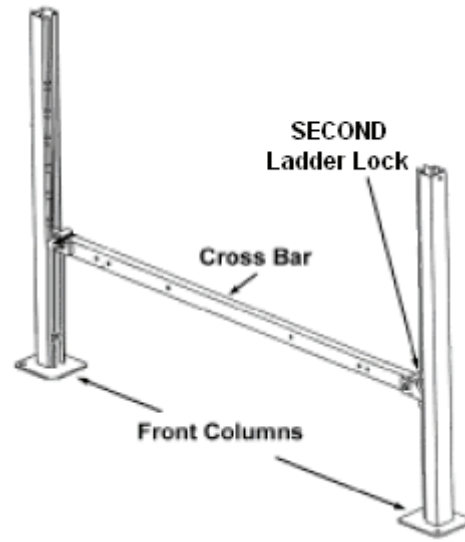

(Fig. 4b)

STEP 4

Runway Installation



WARNING BE VERY CAREFUL NOT TO DISTURB THE POSTS AND CROSS RAILS AT THIS POINT AS THEY MAY TIP OVER AND CAUSE PERSONAL INJURY OR HARM.



- 1] Locate the **Main-Side Runway** with the cylinder attached underneath. This runway will be located adjacent the column with the Power Unit attached.
- 2] Position the 3/4" hole on the side of the runway near the power unit location. (Fig. 5)

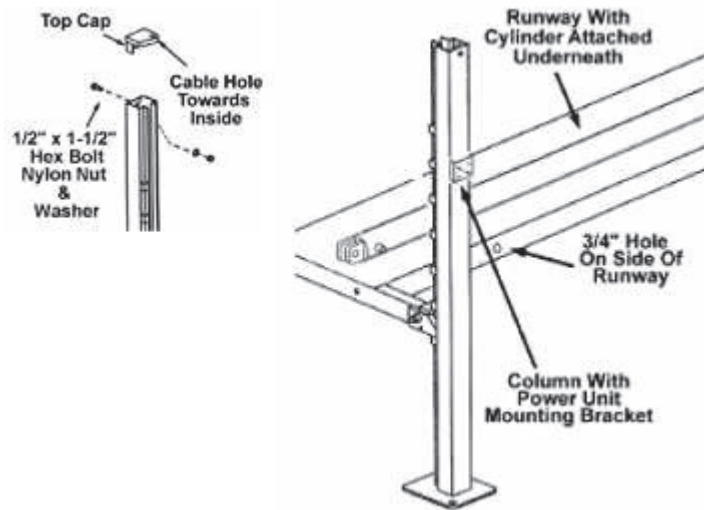

(Fig. 5)

- 3] Line up the front of the **Main-Side Runway** with the Cross Rail bolt holes, then temporarily bolt into position using the 1/2" x 4" hex bolt, nut and washers making sure to pass the bolts through the front tire stops.
- 4] Line up the rear of the **Main-Side Runway** with the Cross Rail bolt holes, then bolt into position using the 1.2" x 4" hex bolt, nylon nut and washers making sure to pass the bolts through the drive-up ramp. (Fig. 5a)

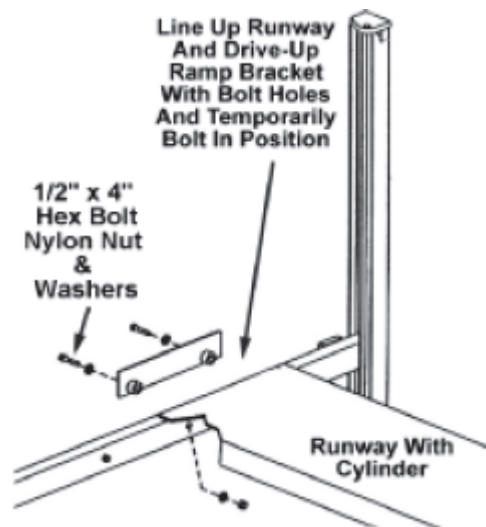

(Fig. 5a)

5] Position the **Off-Side Runway** without the cylinder on top of the Cross Rails, and repeat steps 1 - 4. Leave the mounting bolts loose until installation is complete. After installation is completed, be sure to inspect and tighten all ramp bolts securely.

6] **Level the lift** by adjusting the Lock Ladder studs at the top of each post (Fig. 4a), using your 2' level on each Cross Rail and your 4' level on each Runway.

STEP 5

Cable Installation



DO NOT DAMAGE THE CHROME CYLINDER ROD
DURING THIS PROCESS.



This can ruin the seals of the cylinder,
Resulting in fluid leaks.

1] Make sure **both Cross Rails** are resting on the **second** set of locks. Rails must be equal height from floor. (Fig. 4a)

2] In order to install cables it is necessary to first **extend the hydraulic cylinder**. This can be accomplished by hand, or by applying shop air to the “breather” hole at the bottom of the cylinder. (Alternately, a come-along can be used to carefully extend the cylinder by the cable plate.)

3] Inspect cables to ensure proper lengths. Cables should already be installed at the cylinder, from the factory. Rout the threaded ends through the pulleys, and attach them to the tops of the posts, as shown (Fig. 6).

Note: See **STEP 6** (below) for properly routing the cables through the **Slack-Cable Safety** mechanism, **before attaching to the post-tops**.

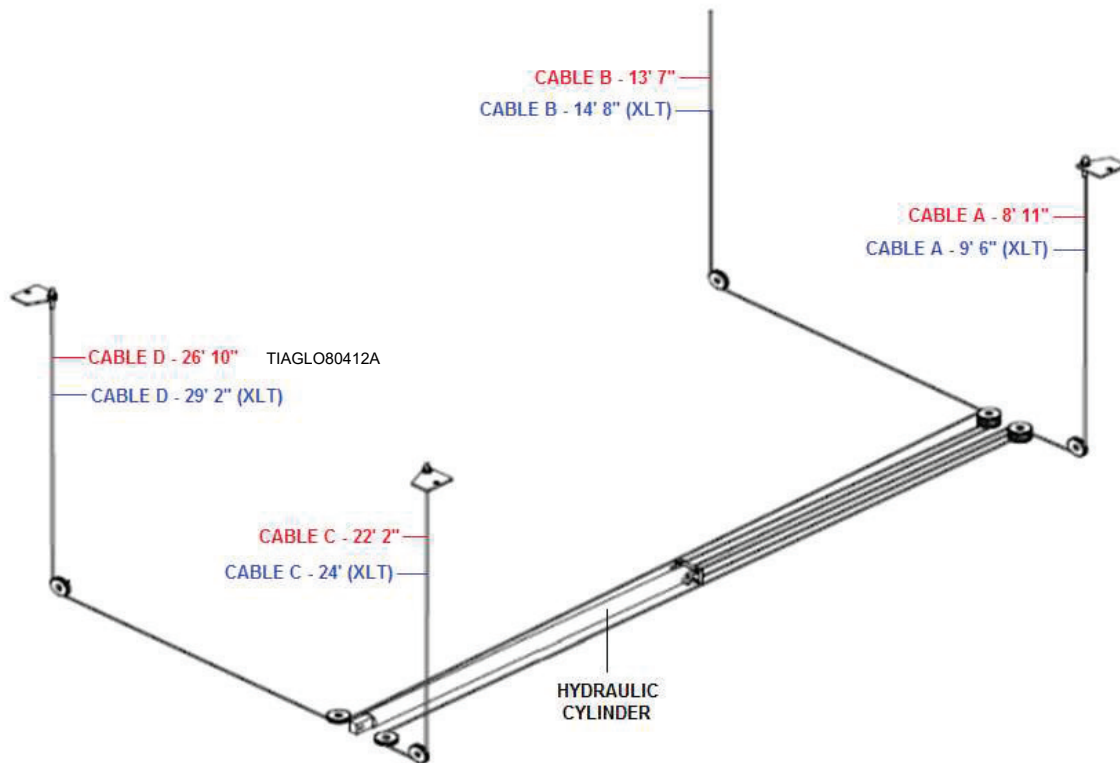

(Fig. 6)

STEP 6

Slack Cable Safety Mechanism

1] **Before** securing the cables to the post tops, it is important to thread them through the **Slack Cable Safety** mechanism correctly, to ensure proper operation. (Fig. 7a - 7c).

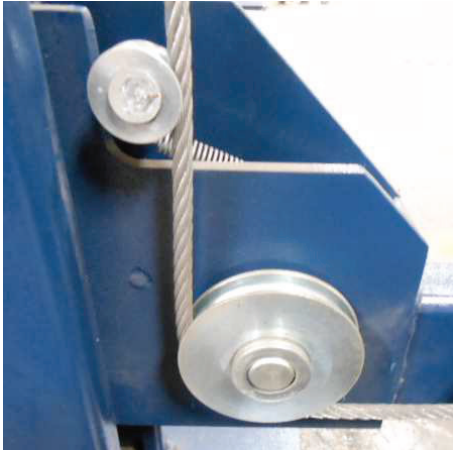

(Fig. 7a)



(Fig. 7b)

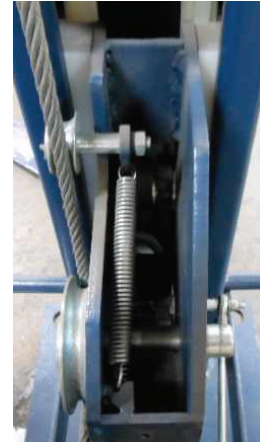

(Fig. 7c)

STEP 7

Cable Installation – (continued)

1] Install flat-washer and nyloc nut on threaded end of cable at top of post. Tighten until several threads show past the nut. (Fig. 8a)

Note: Remember to replace the Cross Rail **Covers** before securing the cables to the post tops (Fig. 8b & 8c).



(Fig. 8a)



(Fig. 8b)



(Fig. 8c)

(Additional Cable Routing Diagrams)

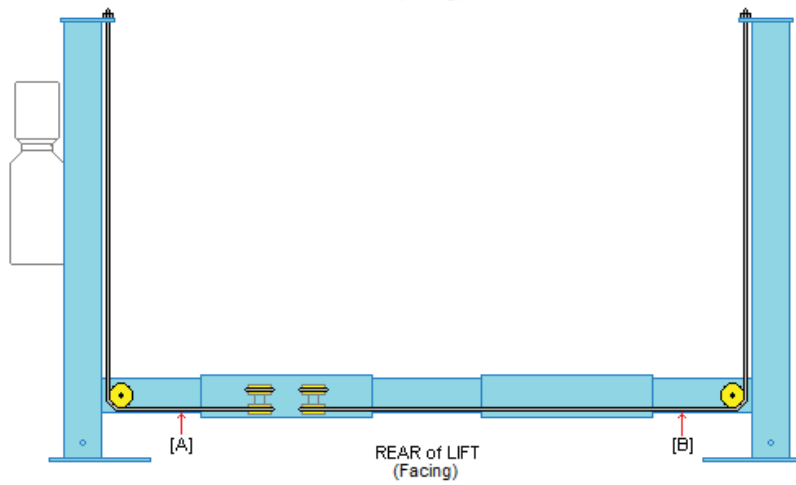
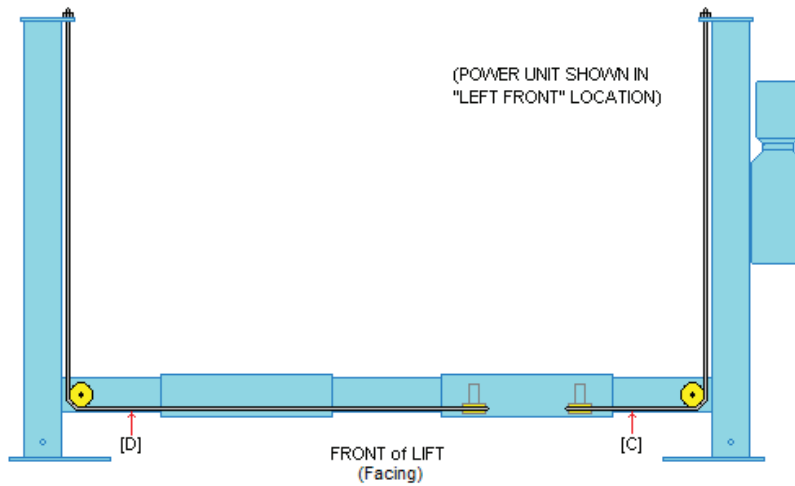
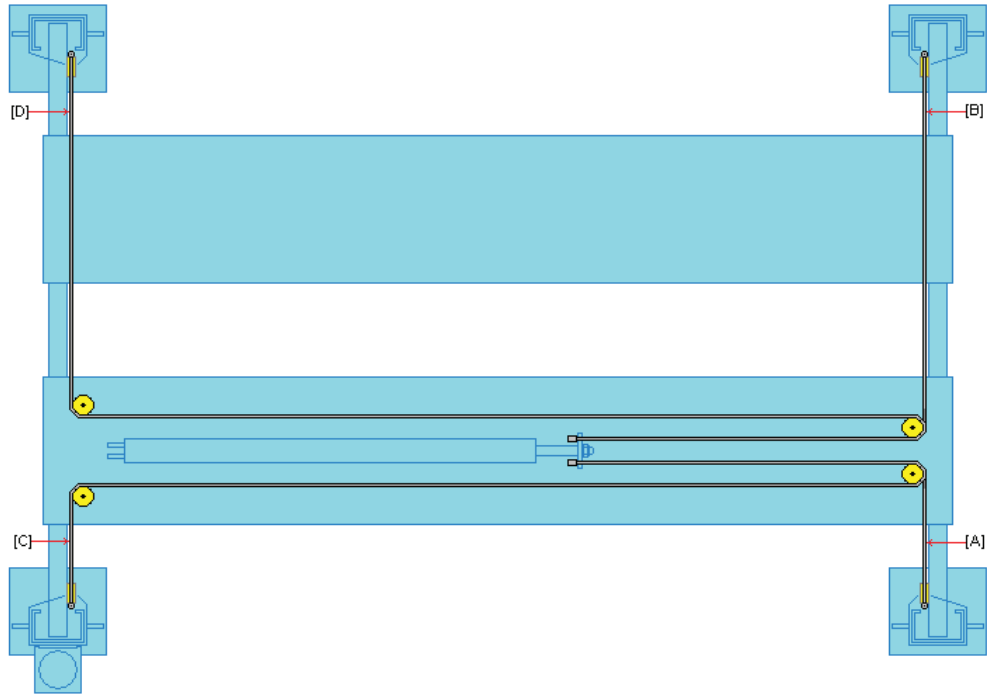

STEP 8

Installing the Power Unit

1] Carefully remove the Power Unit (Fig. 10) from its box and packaging; inspect and immediately notify Eagle Equipment Customer Service if any shipping damage is found.



(Fig. 10)

2] Mount the Power Unit to the mounting bracket on the Main-Side Post, using four (4) 5/16" x 3/4" hex bolts, flat washers, lock washers, and nuts. Use the lower 2 pairs of slotted holes on the power unit bracket.

3] Fill the reservoir to the fill line with hydraulic oil. USE ONLY: **ISO-32** or **AW-32** 10-wt. Hydraulic Oil. **DO NOT USE DEXRON, ATF, MOTOR OIL, TRACTOR OIL or JACK OIL.** AW-32 can be purchased at your local auto parts store.



WARNING: DO NOT use ATF in this lift!



NOTE: Power Unit Reservoir can be filled either before or after mounting it to the lift; whichever the installer finds easier.

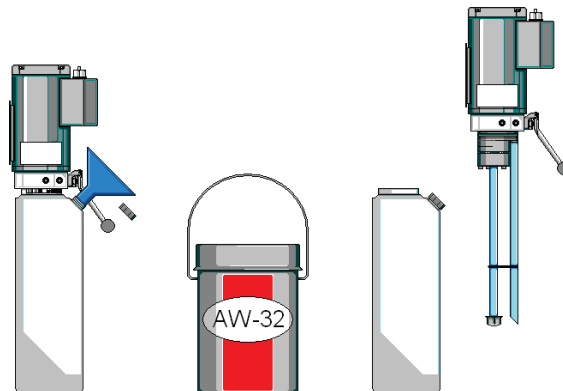

(Fig. 10a)

STEP 9

Installing the Hydraulic Fitting

1] Remove the red plastic plug from the pressure port. Install the hydraulic O-Ring Elbow fitting (Fig. 11) into this port. Wind the fitting in by hand until the O-Ring is up against the face of the pump and the Elbow faces down. Hold the fitting in this position with a wrench and tighten the jamb nut with a second wrench until the washer compresses the O-Ring. **Do not use Teflon tape.**



(Fig. 11)



NOTE: You may find a Straight Adapter Fitting (13A) in your hardware box.
This is **NOT USED** on the Eagle Power Unit.



DO NOT USE THIS FITTING!

Use of this fitting **WILL** cause leaks.

******THIS NEEDS TO BE CHANGED TO USE THE STRAIGHT FITTING WITH THE ELBOW ******

(13A)



STEP 10

Installing the Hoses

1] Connect one end of the **short hydraulic hose** to the Elbow fitting at the pump. Connect the other end of the hose to the bulk-head fitting in the Main-Side Runway. **Do not use Teflon tape.**

2] The **long hydraulic hose** (under the runway) comes installed from the factory. Confirm routing as illustrated (Fig 12 & 12a).

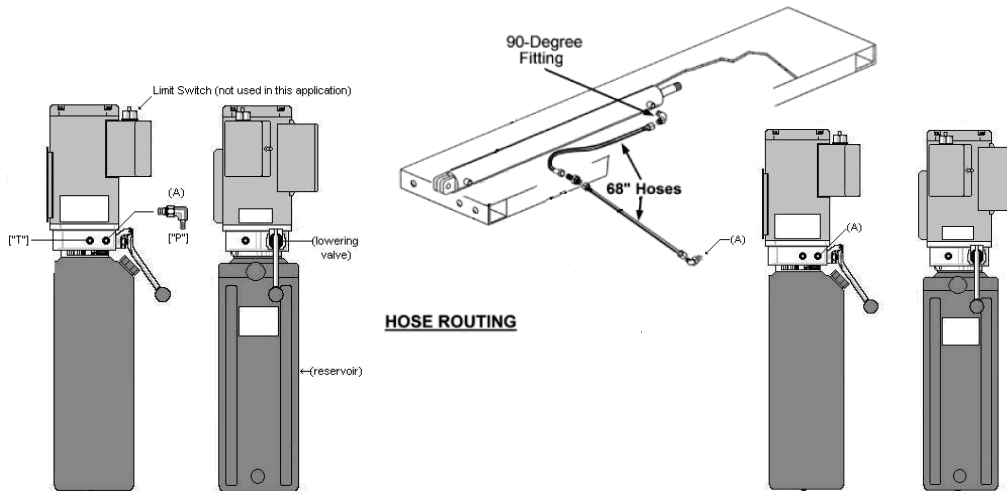

(Fig. 12)

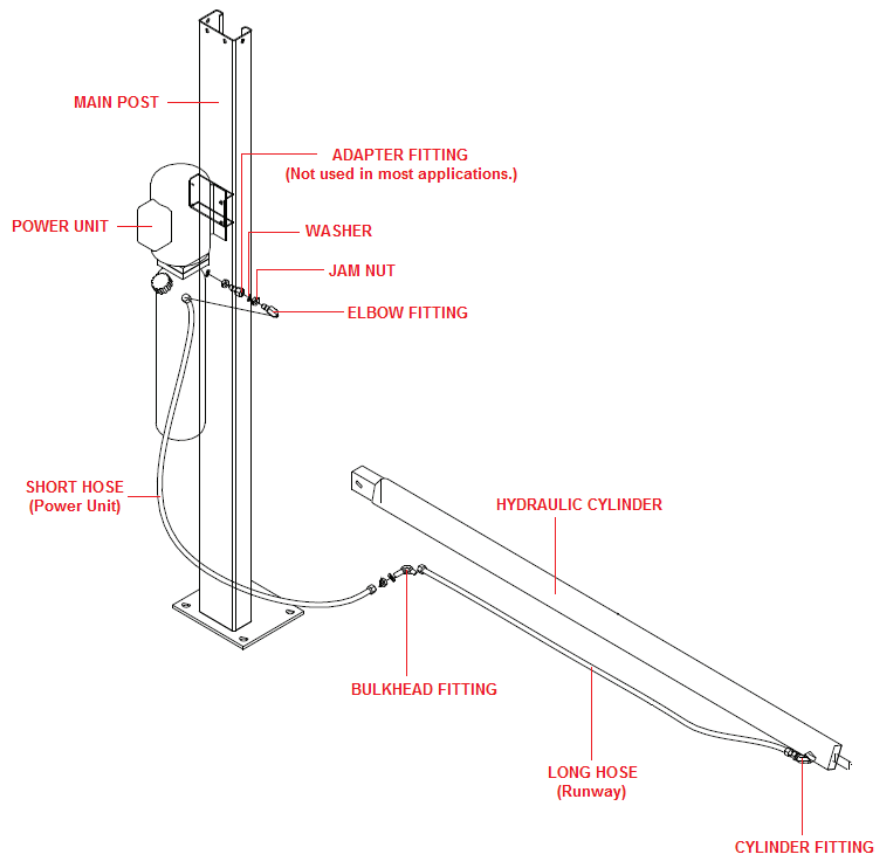

(Fig. 12a)

STEP 11

Start Up



NOTE: This model comes with optional Power Units.



**If you purchased the 110v option, you need only plug it into a properly rated receptacle.
(Proceed with “Start Up” instructions below, then continue on to STEP 14)**

**If you purchased the 220v option, a certified electrician
will need to make the final connection for your lift.
(See STEP 12A)**

- 1] Make sure the reservoir is filled with **AW-32 hydraulic oil**.
- 2] Spray inside corners of columns, where the guide blocks slide, with lithium grease.
- 3] **Press the “UP” switch on the power unit.** Lift will slowly raise.



IF THE LIFT DOES NOT RAISE



- CHECK** hose connections: Fluid should be pumping through the hose connected to the Power Unit.
- CHECK** fluid level: Verify pick-up tube inside reservoir is connected to pump.
- CHECK** electrical connection: Verify 220v, 20@, 1ph connection is properly wired.
- CHECK** Power Unit Priming: See “**Priming Procedure**”, STEP 12B, on page 27.

- 4] Run the lift up and down a few times to bleed the hydraulic system then top off the reservoir with the lift in the fully lowered position.
- 5] Be sure that all four (4) Cross Rail locks are clicking simultaneously and that Slack Safety Cable mechanisms are functioning properly. Re-adjust the cables as necessary. (See STEP 6.)

STEP 11A

Wiring the Lift



WARNING FINAL ELECTRICAL CONNECTION MUST BE MADE BY A CERTIFIED ELECTRICIAN.



1] The power unit may or may not come with a “pig-tail” already attached and wired to the motor. It is recommended that a twist-lock connection be installed at this pig-tail as an emergency disconnect (Fig. 13).

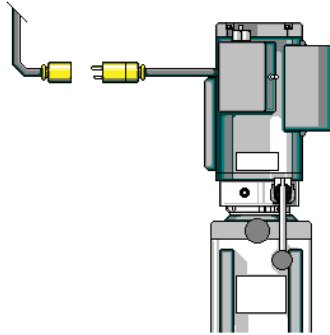

(Fig. 13)

2] Wiring may vary, depending on the Power Unit. The typical connection is L1 to black power unit wire, L2 to white power unit wire, Neutral and Ground both connect to the chassis of the power unit. (Refer to wiring diagram on the inside of your switch cover for confirmation.)

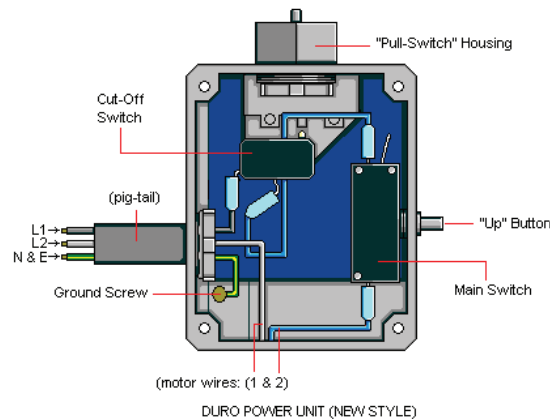

(Fig. 13a)



WARNING DO NOT ASSUME WIRING COLORS OR LABELS ARE ACCURATE. VERIFY THE WIRING INSIDE SWITCH BOX OF POWER UNIT IS ROUTED CORRECTLY TO PROVIDE 220v/20@/SINGLE PHASE TO THE SWITCH AND MOTOR, WITH PROPER GROUND.



! IMPORTANT !

STEP 11B

POWER UNIT PRIMING PROCEDURE

THE PROBLEM: Power unit runs fine but will not pump any fluid.

Step 1 – Locate the check valve, the flush plug to the left of the lowering valve.
(See illustration below.)

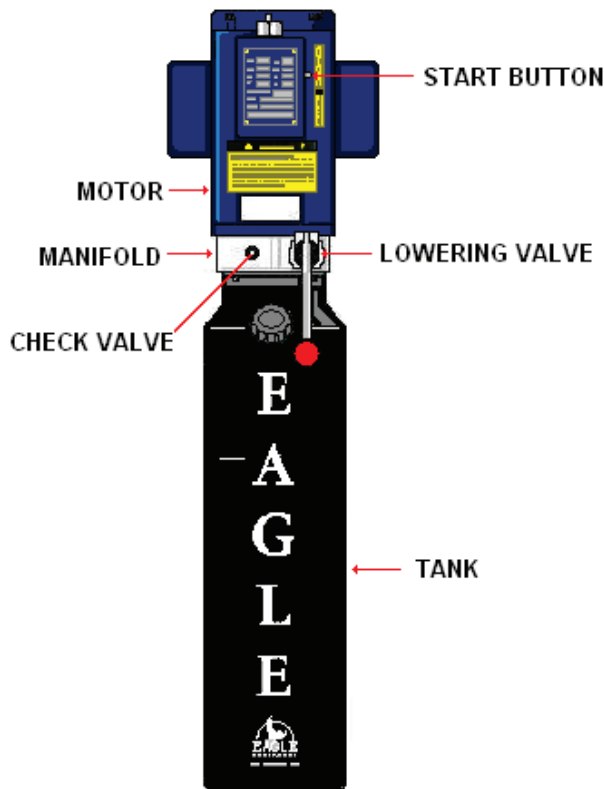

Step 2 – Using an Allen wrench and shop towel – with shop towel in place to catch fluid – loosen the check valve plug 2-1/2 turns to allow it to leak.

Step 3 – Push the **START** button for one second, then release for three seconds. Repeat these steps until the unit starts pumping fluid.

Step 4 – Tighten the check valve.

THE POWER UNIT SHOULD BE PRIMED

STEP 12

Safety Linkage Rod Assembly

1] Install the Lock Rods and Linkage Rods as shown below making sure to position the safety handle adjacent the power unit. Pay careful attention to assemble the FRONT and REAR linkage assemblies as shown. Improper assembly will result in safety lock failure. (Fig. 15)

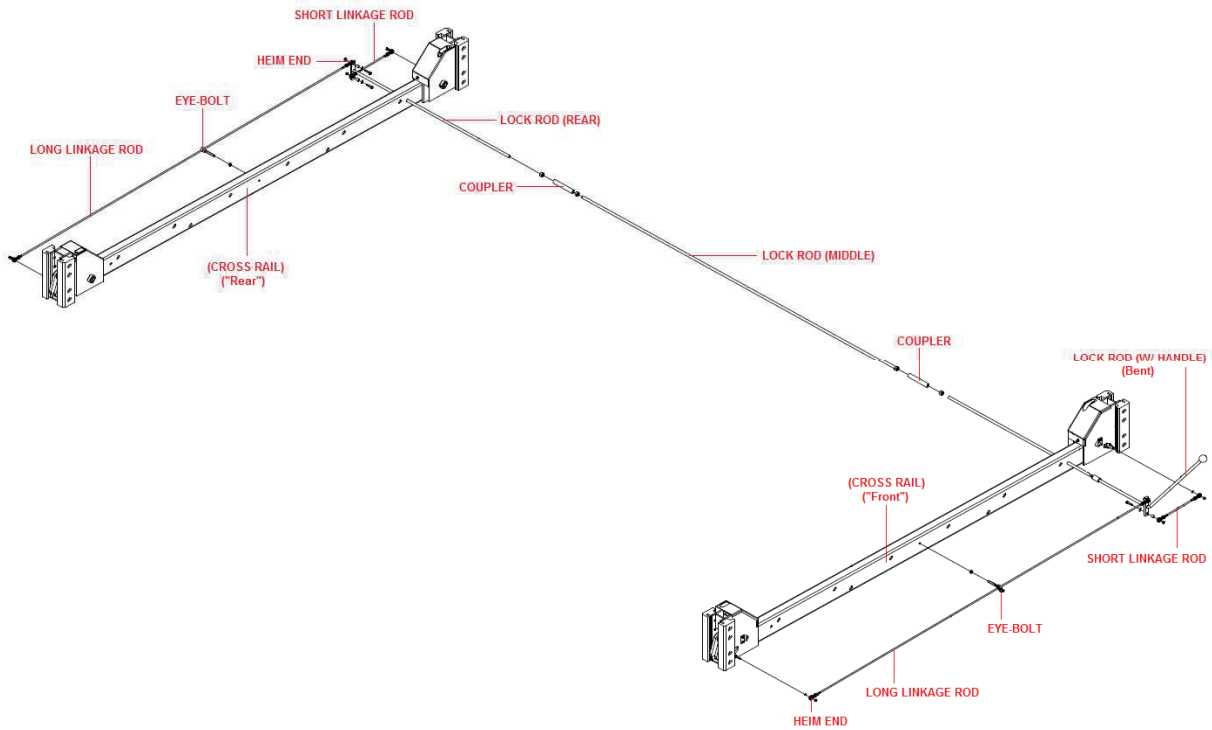

(Fig. 15)

2] Assemble the Heim-Ends on the Linkage Rods as shown. (Figs 15a-15c)

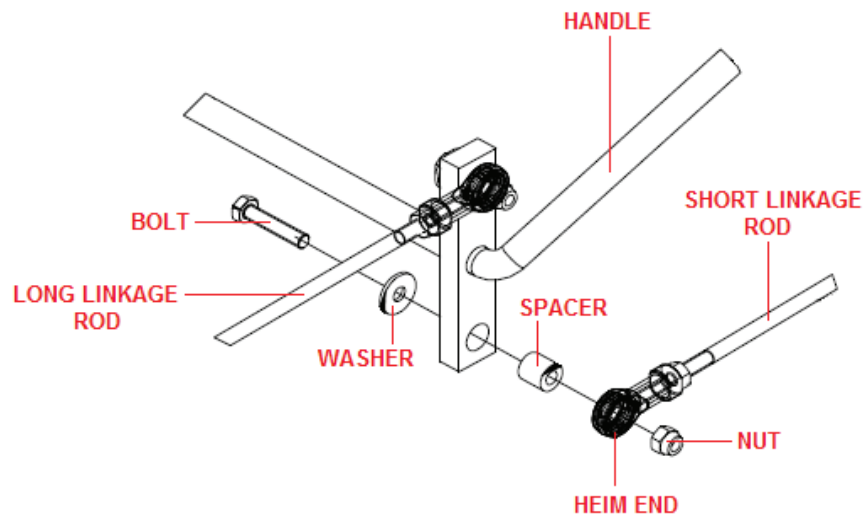

(Fig. 15a)

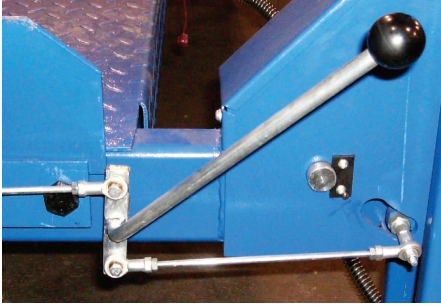

(Fig. 15b)

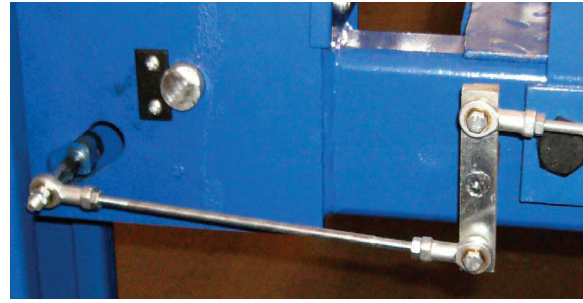

(Fig. 15c)

3] With the lift **still in the second locking position**, re-check and adjust **Lock Ladders** to ensure deck is level side-to-side and front-to-rear.



WARNING WHEN LOWERING LIFT ALWAYS MAKE SURE ALL FOUR LOCKS ARE DISENGAGED.



If one of the locks inadvertently engages on descent the lift and/or vehicle may shift causing personal injury or death.

STEP 13

Adjusting the Cables

1] All **cable adjustments** should be made at the Top Cap of the posts. It may be necessary to secure the cable end with a pair of vice grips inside the carriage.

2] Tighten all four cables for equal tension. Raise lift. Locks should engage simultaneously.

3] Run the lift up and down a few times to ensure that the locks are engaging uniformly and that the safety release mechanisms are functioning properly. Re-adjust if necessary. Verify lift raises to maximum height, and all four cross-rail locks clear post locks.

Note: If locks do not engage at the same time, re-adjust cables as necessary.



NOTE: Cable tension is very important to the correct and safe operation of your lift. See the Maintenance Section of this manual for information on maintaining proper cable tensions.



NOTE: There will be some initial stretching of the cables in the beginning. It will be necessary to re-adjust the cables a week after first use. Then every six (6) months thereafter.



STEP 14

Installing Ramps & Wheel Stops

- 1] Determine the preferred direction of vehicle approach.
- 2] Install Wheel Stop and Approach Ramp **Brackets** on the runways.
- 3] Drop in the Wheel Stops and Approach Ramps, as shown. (Fig. 16a – 16d)
- 4] Once completed, drive a vehicle onto the lift runways, and run the lift up and down a few times to ensure that the locks are engaging uniformly and that the safety release mechanisms are functioning properly. Re-adjust if necessary.

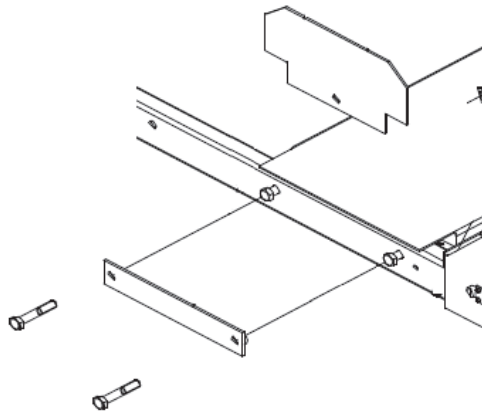

(Fig. 16a)

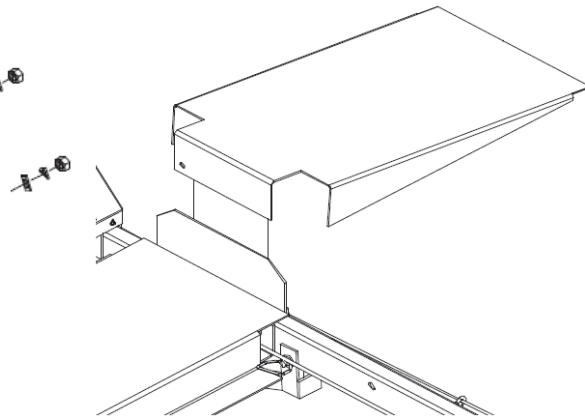

(Fig. 16b)



(Fig. 16c)



(Fig. 16d)

STEP 15

Installing the Caster Kit



NOTE: Caster Kit is Optional.



This lift is designed to use either as a mobile lift, or as a permanently floor mounted lift.

If you want to permanently anchor your lift to the floor, skip to Step 15.

1] Assemble and install Casters as shown (Fig. 17).

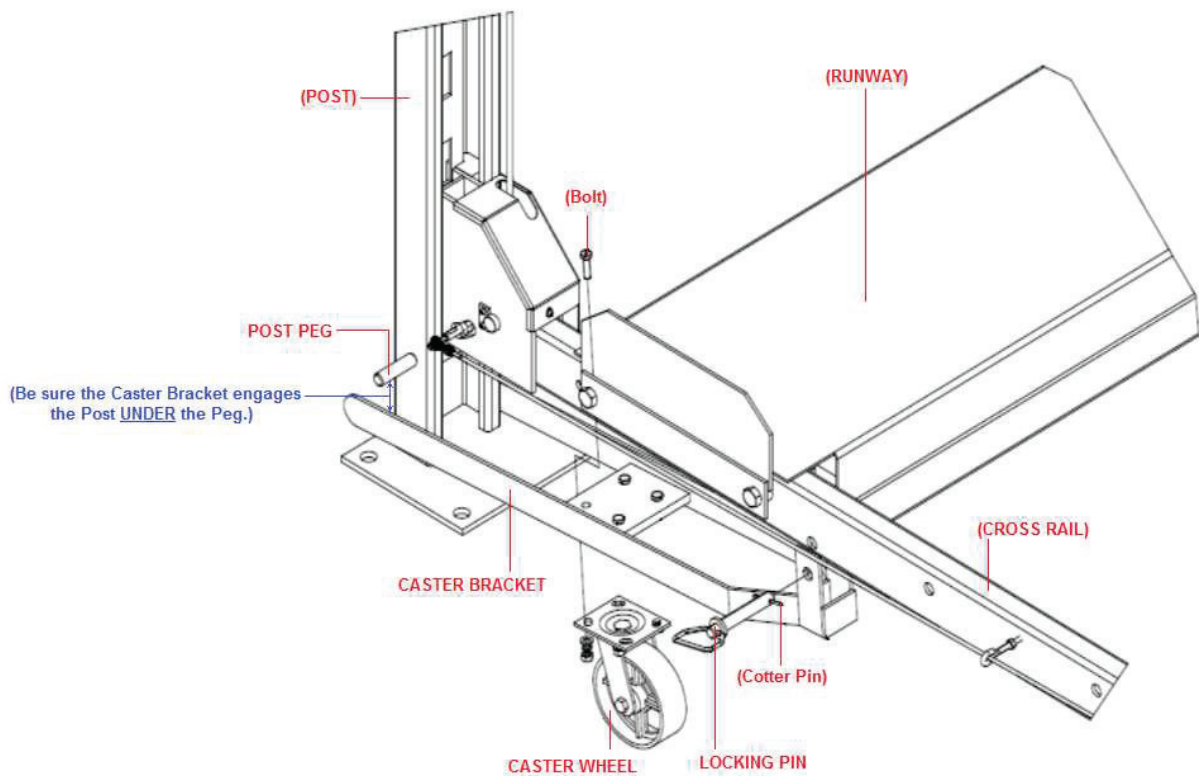

(Fig. 17)



(Fig. 17a)

STEP 16

Securing the Posts



NOTE: Anchoring Posts to the floor is Optional.



This lift is designed for either permanent floor mounting,
or as a mobile lift for use with the Caster Kit (included).

(You WILL NOT be able to use your Caster Kit once the lift is secured to the floor.)

If you do not want to permanently anchor your lift to the floor, skip this step.

- 1] Verify your floor meets the required specifications. (See **Step 2**, above.)
- 2] Double check all dimensions and make sure the layout is square. Verify the position of the Main Post within the square.
- 3] Once the Main Side Post is in its final position, drill holes in the concrete using the base plate of the post as your template (**Fig. 18**). Use a $\frac{3}{4}$ " hammer drill bit and drill straight clear holes. Drill all the way through the slab when possible to allow for replacing an anchor if necessary. Keep the hammer drill straight when drilling to prevent egging out the holes.

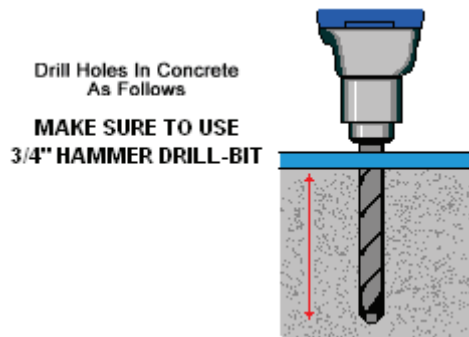

(Fig. 18)

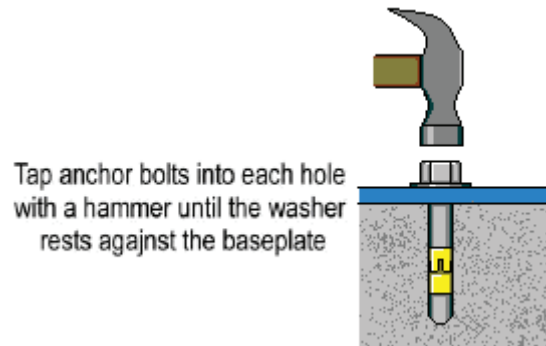

(Fig. 18a)

- 3] Once holes are drilled, vacuum out the dust and insert anchor bolt(s) into hole(s) and tap down until washer rests against the base plate (**Fig. 18a**). Be sure nut is flush with top of bolt before tapping into hole.

DO NOT TIGHTEN AT THIS TIME.



**CAUTION: Hitting the anchor bolts too hard
may result in damaged threads,
which may prevent proper tightening of the nut.
Tap firmly, but carefully.**



- 4] Before tightening the anchor bolts, check for plumb of the Main Side post with a 4' level. Shim as necessary (**Fig. 18c**). Shims must be installed at all anchor points where there is a gap between the base plate and the concrete. Do not shim more than $\frac{1}{2}$ ".

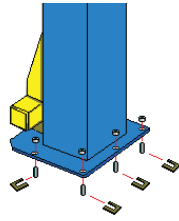

(Fig. 18c)

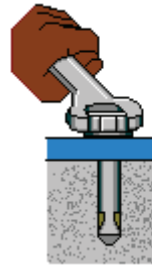

Tighten nut
120 ft. lbs.
DO NOT use
an impact wrench.

(Fig. 18d)

5] Once the Main Side post is positioned and shimmed correctly, secure it to the floor by tightening the anchor bolts to 120 foot-pounds. **DO NOT** use an impact wrench (Fig. 18d).

6] All anchors must have a minimum of 3 ¼" embedment in the concrete. If the top of the anchor exceeds 2 ¼" above the floor grade, you **DO NOT** have enough depth on the anchors.

7] Re-check the position and placement of the Off Side Posts. Make sure the posts are plumb and square in relation to the Main Side Post.

8] Drill through the holes in the base plates and install anchor bolts and secure the Off Side Posts as described in **Step 5, numbers 1-6 above.**

9] All posts are now secured.

OPERATION

RAISING A VEHICLE ON THE LIFT

- 1] Read these Operating Instructions completely before using the lift.
- 2] Position vehicle tires in the center of each ramp and center the vehicle between the columns to distribute the weight most evenly. **(DO NOT BACK VEHICLE ONTO LIFT.)**
- 3] Set parking brake and/or use wheel chocks to hold vehicle in position.
- 4] Before raising vehicle, be sure all personnel are clear of the lift. Pay careful attention to any overhead obstructions.
- 5] Press the button on the power unit to raise the raise vehicle to the desired working height.
- 6] Lower lift onto nearest safety locks to support load.
- 7] Do not permit the cables to go slack.



WARNING

When working on a vehicle



WARNING

ALWAYS make sure that ALL LOCKS are engaged.

NEVER work beneath a vehicle without it resting securely on the safety locks.

LOWERING A VEHICLE

- 1] First, raise the lift to clear all the safety locks.
- 2] Disengage safety locks by holding handle down.
- 3] Push the lowering handle on the power unit and hold until the lift has descended completely.
- 4] If the lift is shaking, vibrating or swaying, reduce the descending speed.



WARNING

When lowering lift PAY CAREFUL ATTENTION.



WARNING

ALWAYS make sure that ALL LOCKS are disengaged.

If one of the locks inadvertently locks on descent the lift and/or vehicle may dislodge causing personal injury or death.



WARNING

DO NOT USE LIFT IF WORN OR DEFECTIVE PARTS ARE EVIDENT.



WARNING

Immediately remove lift from service until repairs can be made.

Replace all worn parts before lift is returned to operation.

- 1] If any component of the lift is found to be defective, DO NOT USE LIFT!
- 2] Never operate the lift with any person or equipment below.
- 3] Always stand clear of lift when raising or lowering.
- 4] Never exceed rated capacity.
- 5] Always ensure safeties are engaged before any attempt is made to work on or near vehicle.
- 6] Never leave lift in an elevated position unless it is settled firmly upon the safety locks.

MAINTENANCE

DAILY MAINTENANCE

- 1] Give the lift a quick once-over before using it each day. Check for any obvious leaks, or defects. Inspect cables and hoses for any sign of wear.
- 2] Verify lift is operating properly, raising levelly and all locking mechanisms are working correctly.

WEEKLY MAINTENANCE

- 1] Lubricate all cable pulleys. Grease the cross rail tracks inside the towers.
- 2] Check all nuts and bolts; tighten where necessary.
- 3] After the first week, check cable tension and adjust as necessary. Check every 6 months after.

MONTHLY MAINTENANCE

- 1] Check and lubricate all safety mechanisms; ensure they are in proper working order. Replace any worn or defective parts.
- 2] If mounted to floor, inspect all anchor bolts and tighten as necessary.
- 3] Inspect all moving parts; replace any worn or defective parts.

CABLE INSPECTION AND MAINTENANCE

- 1] Lift cables normally require replacement every four to five years.
- 2] Lift cables should be replaced if you see three or more broken wires in one strand.
- 3] Replace the cables if you see: corrosion or rusting on the wires or ends, kinking, crushed areas, cutting, spreading, a cable core protruding, or any other abnormality.
- 4] If any cable defects are found the lift should be shut down immediately until the defective cable(s) have been replaced.
- 5] Cables and other lift parts should be kept free of corrosive agents, solvents, and road salt. If such agents are spilled or splashed on any lift component, immediately rinse and wipe down with a clean rag. Spray cables every three months with Penetrating Oil and wipe down. Failure to keep cables free of corrosive agents will lead to reduced service life, cable failure, etc. which could result in property damage and/or personal injury.

TROUBLE-SHOOTING

ANCHOR BOLTS DO NOT TIGHTEN, OR PULL OUT OF FLOOR

- 1] Faulty concrete, or insufficient floor thickness: Have floor checked for proper specifications.
- 2] Wrong size drill bit size was used. Move the lift and drill new holes with the correct size bit.

LIFT DOES NOT RISE; NO MOTOR NOISE

- 1] No power: Check breaker, power to Power Unit; verify proper wiring.
- 2] Bad switch: Check, replace if necessary.
- 3] Cut-off switch engaged (if present): Verify wiring of cut-off switch.
- 4] Bad motor: Repair or replace.

MOTOR RUNS, BUT LIFT DOES NOT RISE

- 1] No draw from pump: Verify fluid is flowing through hose. Check pick-up tube inside reservoir.
- 2] Perform Priming Procedure (**STEP 11B**).
- 3] Check lowering valve for debris or bad o-ring. Inspect check-valve, if present.
- 4] Bad pump: repair or replace.
- 5] Bad motor: Repair or replace.

LIFT RAISES, BUT LABORS

- 1] Wrong Voltage: Lift may be wired at 110vac; verify 220vac.
- 2] Improper flow: Check pressure rating of pump, and verify out-put.
- 3] Vehicle too heavy for lift: Verify weight of vehicle.
- 4] Bad power unit: Repair or replace.

LIFT SHUDDERS OR SHAKES WHEN RAISING OR LOWERING

- 1] Mechanical Binding: Inspect and correct.
- 2] Incorrect fluid used: Verify AW-32, and replace incorrect fluid if necessary.
- 3] Air in lines: Should bleed through reservoir cap; check for restrictions. Bleed manually if necessary.

LIFT RAISES TOO SLOWLY

- 1] Wrong voltage or fluid flow (see above).
- 2] Excessive weight (see above).
- 3] Mechanical binding in structure: Inspect for binding; verify the plum and square of installation.
- 4] Hydraulic flow is restricted: Check hoses and fittings for blockage. Check lowering valve for by-pass.

LIFT RAISE UNEVENLY

- 1] Uneven distribution of weight: Vehicle improperly loaded or out of balance. Re-check and correct.
- 2] Cables out of adjustment: Readjust. Check cables for stretching, fraying or wear. Replace if necessary.
- 3] Unequal hydraulic fluid flow: Check hoses and fittings for restrictions.
- 4] Mechanical binding in one or more post(s): Check and correct as necessary.

SAFETY LOCKS DO NOT ENGAGE, OR ENGAGE OUT OF SYNC

- 1] Cross rails are not raising evenly: (See above.)
- 2] Locking mechanism(s) are dirty or require lubrication: Lubricate with WD-40, or similar oil.
- 3] Locks are restricted: Check and verify release cable or locking mechanism is not restricted, or jammed.
- 4] Defective components: Inspect and correct or replace as necessary.
- 5] Grease or oil on inside of post is preventing the latch from resetting.
- 6] Slack Cable Safety mechanism out of adjustment; correct as necessary.

LIFT LOWERS UNEVENLY

- 1] Uneven distribution of weight: Vehicle improperly loaded or out of balance. Re-check and correct.
- 2] Mechanical binding: Inspect and correct.
- 3] Hydraulic restriction: Inspect and correct.
- 4] Cables out of adjustment: Inspect and correct.

LIFT LOWERS SLOWLY

- 1] Mechanical binding: Inspect and correct.
- 2] Hydraulic restriction: Inspect and check. Check Lowering valve for dirt, debris or defect. Clean or replace.

LIFT LOWERS TOO QUICKLY

- 1] Wrong fluid used in lift: Verify AW-32, and replace incorrect fluid if necessary.
- 2] Improper Hydraulic Flow: Check for leaks, or defective flow-restrictors or lowering valve.

LIFT WILL NOT COME DOWN

- 1] Verify Safety Locks are disengaged.
- 2] Verify Slack Cable Safety mechanisms are disengaging properly.
- 2] Check for mechanical binding or restriction. Verify cross rails are level.
- 3] Consult professional.

PARTS LISTING

Main Structure

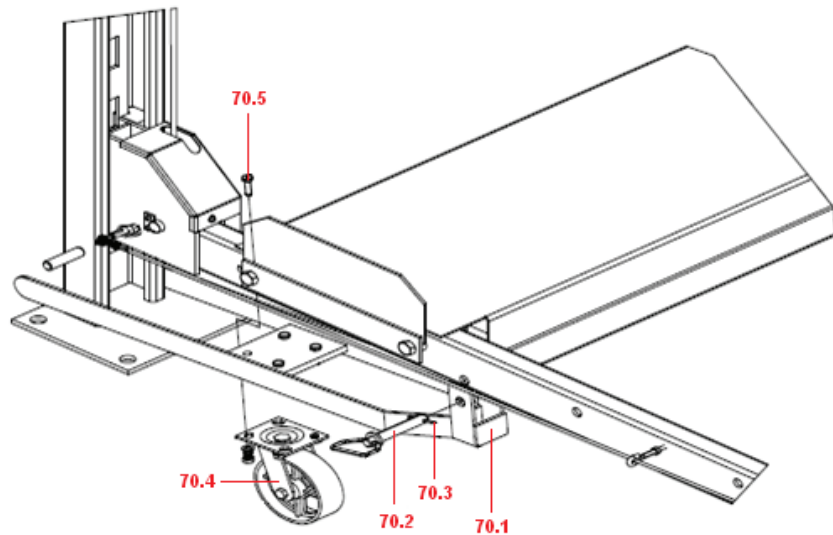
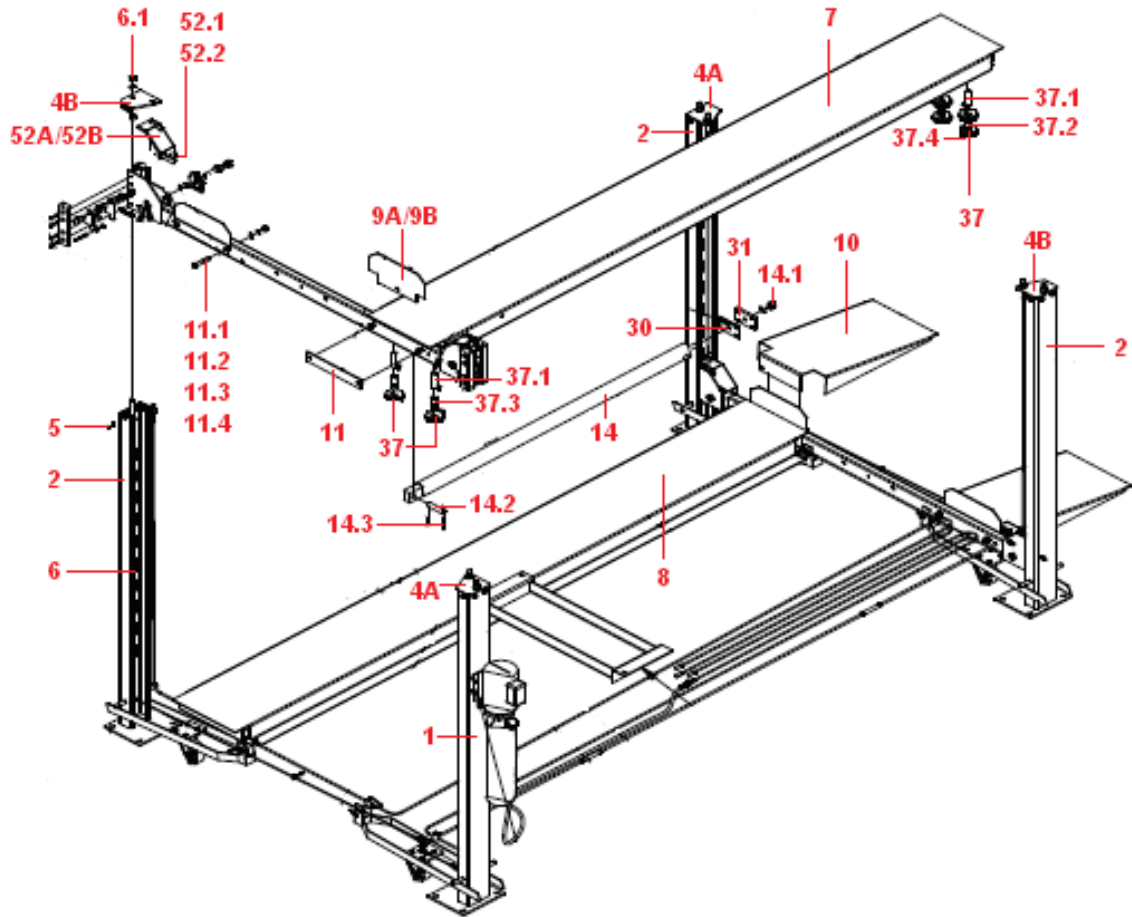

Sub-Structures

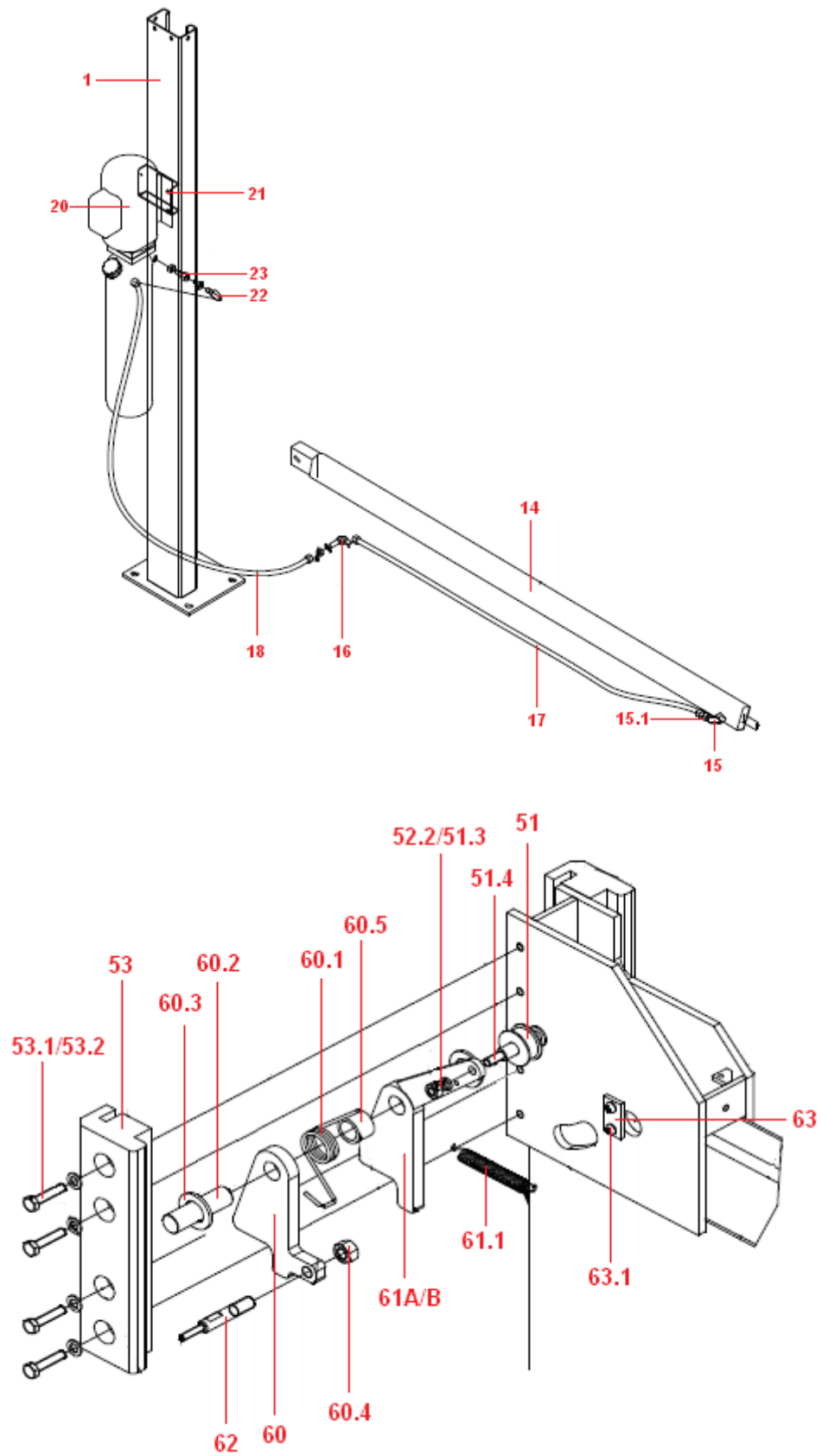

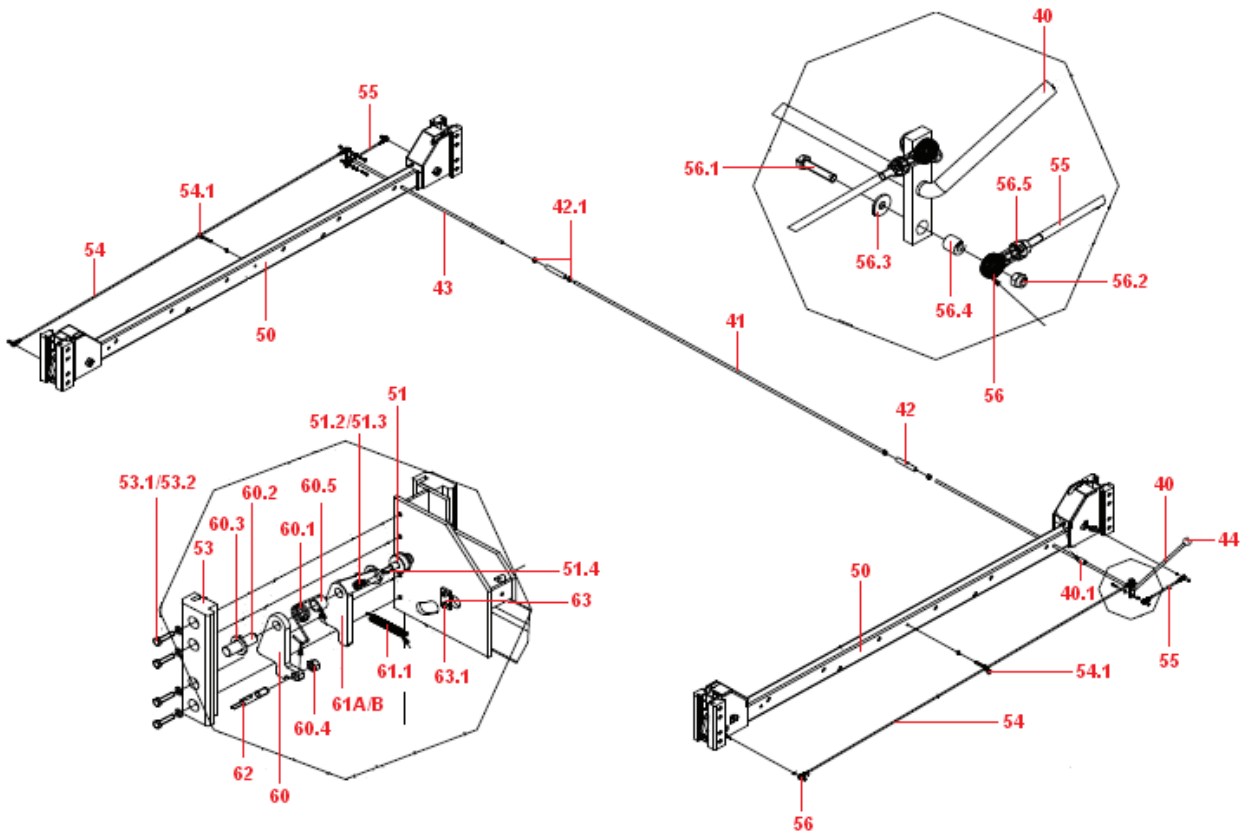
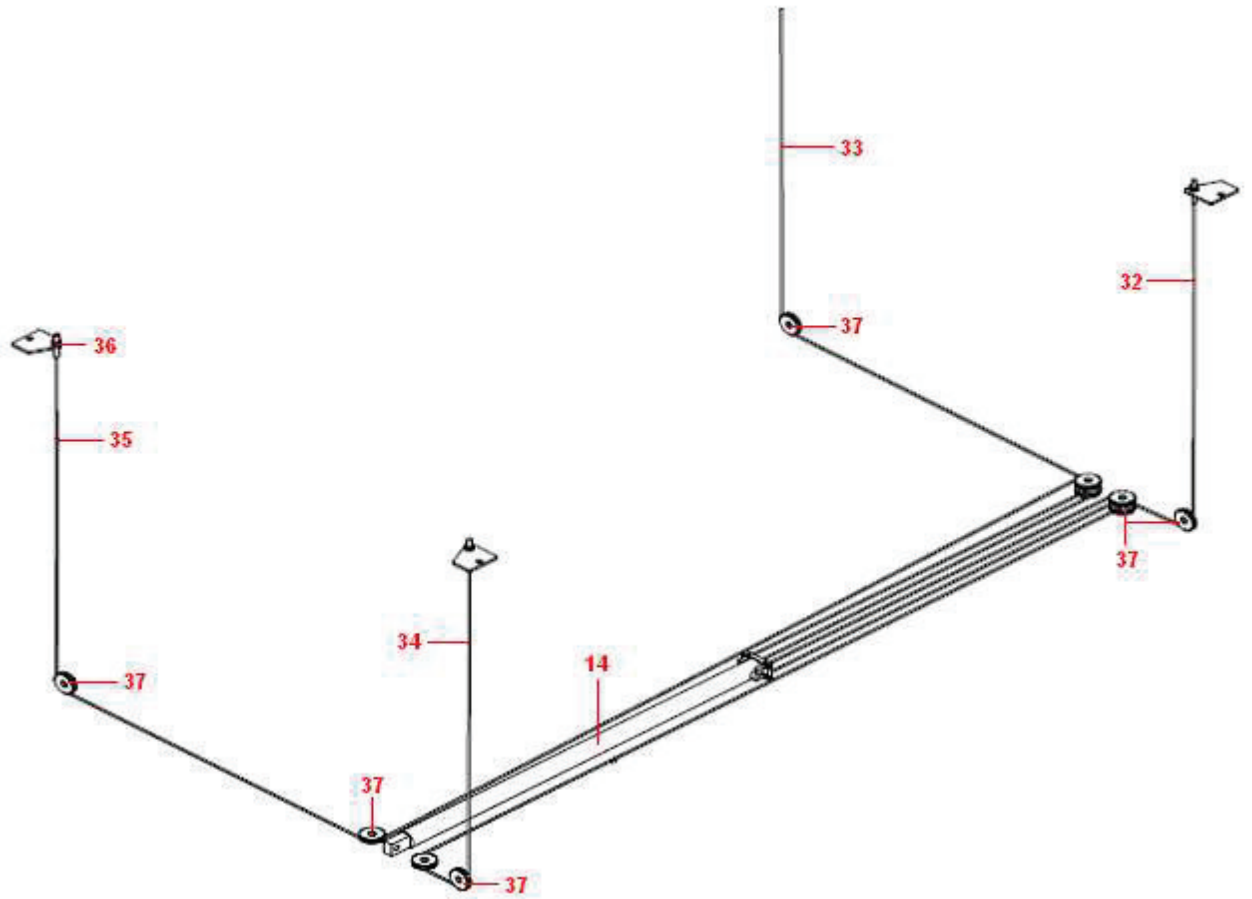

8000LBS. 4-POST STORAGE LIFT

09.23.2014

<u>REF</u> <u>#</u>	<u>DESCRIPTION</u>	<u>QTY.</u>
1	POST / TOWER - MAINSIDE (POWER UNIT)	1
2	POST / TOWER (SLAVE)	3
4A	TOP PLATE - A	1
4B	TOP PLATE - B	1
5	HDW SET (BOLT, NUT, LOCKWASHER - 1 EA.)	4
5.1	BOLT	4
5.2	NUT	4
5.3	LOCKWASHER	4
6	LADDER	1
6.1	NUT, LADDER	8
6.2	WASHER, LADDER	4
7	TRACK / RUNWAY (MAINSIDE)	1
8	TRACK / RUNWAY (OFFSIDE)	1
9A	WHEEL STOP ("EAGLE")	2
9B	WHEEL STOP ("BIRD")	2
10	RAMP, ALUMINUM	2
11	BRACKET, RAMP MOUNT	4
11.1	BOLT, RAMP MOUNT BRACKET	8
11.2	WASHER, RAMP MOUNT BRACKET	8
11.3	LOCK WASHER, RAMP MOUNT BRACKET	8
11.4	NUT, RAMP MOUNT BRACKET	8
12	TOOL / JACK TRAY (37")	1
	TOOL / JACK TRAY (43") (GLO-8000XLT)	(n/a)
14	CYLINDER (3070)	1
14.1	NYLOCK NUT (CYLINDER ROD)	1
14.2	PIN (CYLINDER)	1
14.3	PIN, ROLLED	2
14.4	SEAL KIT (CYLINDER)	1
15	FITTING, ELBOW W/ O-RING (CYLINDER)	1
15.1	JAM NUT (FITTING)	1
16	FITTING, ELBOW W/ NUT (INSIDE TRACK)	1
16.1	JAM NUT (FITTING)	1
17	HOSE, TRACK-TO-CYLINDER	1
18	HOSE, POWER UNIT	1
20	POWER UNIT	1
21	HARDWARE SET	4
21.1	HEX BOLT, 5/16"-18 x 1"	4
21.2	HEX NUT, 5/16"-18	4
22	FITTING, ELBOW (W/ O-RING) O-RING (ELBOW FITTING)	1
23	FITTING, STRAIGHT (ADAPTER)	1
30	BLOCK, CABLE RETAINER	1
31	PLATE, CABLE RETAINER	1
32	CABLE, 8' 4"	1
33	CABLE, 13' 4-3/4"	1
34	CABLE, 21' 1/2"	1
35	CABLE 26' 1-3/4"	1
36	NUT (CABLE)	4
36.1	WASHER (CABLE)	4
37	SHEAVE, CABLE (PULLEY)	10
37.1	SHAFT (SHEAVE)	10
37.2	SPACER, SHORT (SHEAVE)	2
37.3	SPACER, TALL (SHEAVE)	2
37.4	KEEPER PLATE	8
38	POLY SHEET	2

40	LOCK ROD, 1/2" x 50" BENT (W/ HANDLE)	1
40.1	SPACER (LOCK ROD)	
41	LOCK ROD, INTERMEDIARY (MIDDLE)	1
42	COUPLER, 1/2" (LOCK ROD)	2
42.1	JAM NUT (COUPLER)	4
43	LOCK ROD, REAR	1
44	KNOB (LOCK ROD HANDLE)	1
50	CROSS RAIL ASSEMBLY	2
51	ROLLER (SLACK SAFETY CABLE)	4
51.1	BOLT (SLACK SAFETY ROLLER)	4
51.2	NUT (SLACK SAFETY ROLLER)	4
51.3	LOCK-WASHER (SAFETY SLACK ROLLER)	4
51.4	SHAFT (SLACK SAFETY ROLLER) BOLT #51.1	4
52A	SHEAVE COVER, L/H (POWER UNIT SIDE)	2
52B	SHEAVE COVER, R/H	2
52.1	SCREW, COVER	4
52.2	LOCK WASHER, COVER	4
53	RUB / SLIDER BLOCK	4
53.1	BOLT (RUB BLOCK)	32
53.2	WASHER A (RUB BLOCK)	32
53.3	WASHER B (RUB BLOCK)	32
53.4	NUT (RUB BLOCK)	32
54	LINKAGE ROD (LONG)	2
54.1	EYEBOLT	2
55	LINKAGE ROD (SHORT)	2
56	ROD END (HEIM END)	8
56.1	BOLT (LINKAGE / HEIM END)	8
56.2	NUT (LINKAGE / HEIM END)	8
56.3	WASHER (LINKAGE / HEIM END)	8
56.4	SPACER (LINKAGE / HEIM END)	8
56.5	NUT, JAM (LINKAGE / HEIM END)	8
60	LOCK PAWL	4
60.1	SPRING (LOCK)	4
60.2	SHAFT (LOCK)	4
60.3	WASHER (LOCK)	4
60.4	NUT (LOCK)	4
60.5	SPACER (LOCK)	4
61A	LATCH, MAINSIDE	2
61B	LATCH, OFFSIDE	2
61.1	SPRING (PAWL)	
62	STAND-OFF BOLT (CROSSRAIL TO HEIM END)	2
63	KEEPER PLATE	2
63.1	SCREW (KEEPER PLATE)	4
70	CASTER ASSEMBLY	4
70.1	BRACKET	4
70.2	LOCK PIN	4
70.3	COTTER PIN	4
70.4	WHEEL	4
70.5	HARDWARE SET (BOLT, NUT, WASHER, LW)	16
	HARDWARE BOX	1
	ANCHOR BOLT 3/4" x 6-1/2" WEDGE	16
	EAGLE DECAL	2
	SERIAL TAG	1

- ADDITIONAL ILLUSTRATIONS -

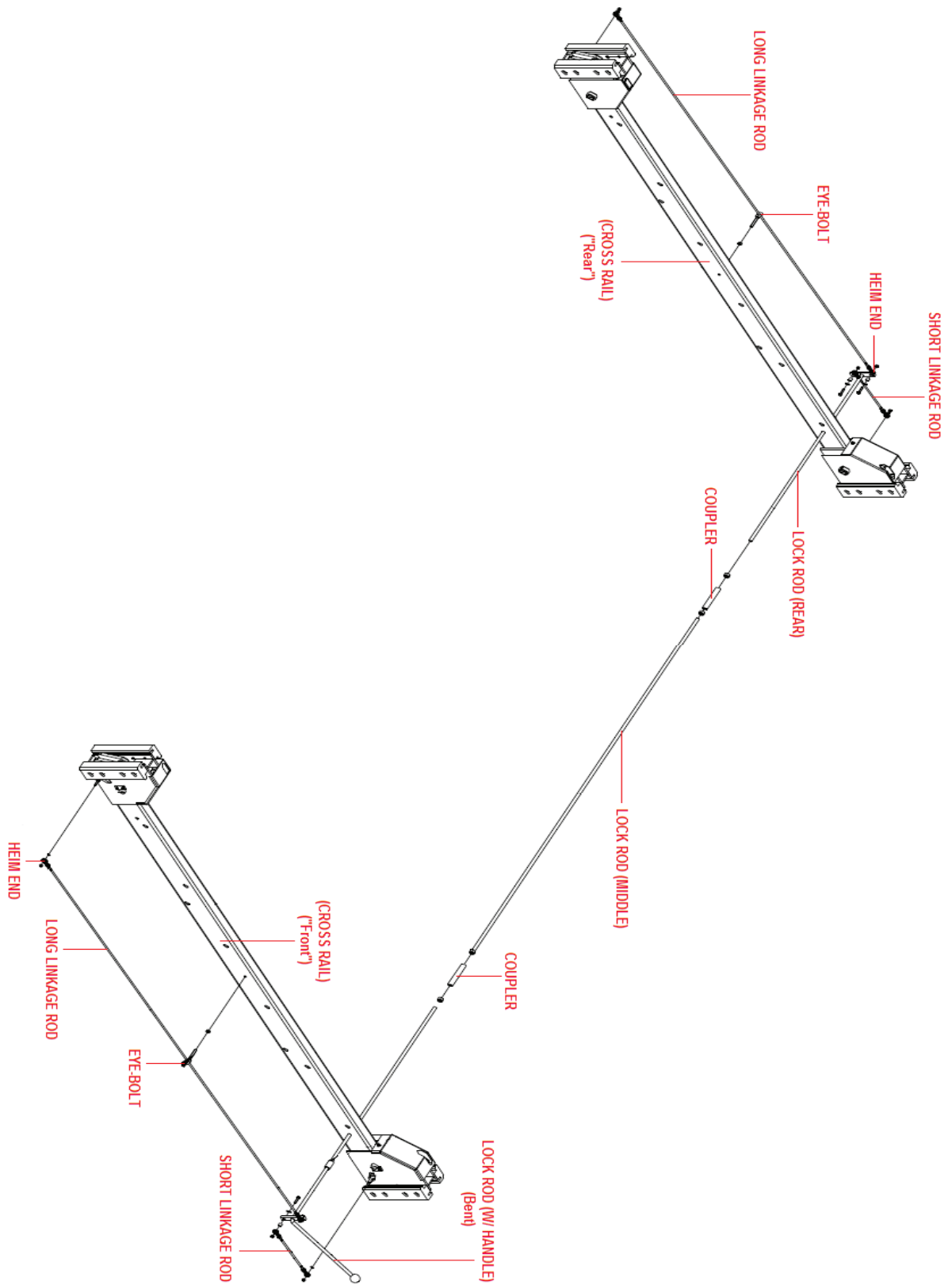

(Fig. 15 – EXPANDED)



Eagle Equipment Lift Warranty

Eagle Equipment warrants to the original retail purchaser of an Eagle Automotive Lift that it will replace without charge any part found under normal use, in the United States or Canada, to be defective in materials or workmanship, **for a period of one (1) year from date of purchase.** Warranty covers parts only; purchaser is responsible for any and all labor requirements.

Exclusions

This warranty will not apply to any machine:

1. Which has not been operated or maintained according to specifications
2. Which has been abused, misused, altered, or improperly maintained
3. Which has been improperly installed or assembled

Other limitations

This warranty does not cover:

1. Parts needed for normal maintenance.
2. Wear parts, which include but are not limited to, cables, hoses, slider blocks, chains and rubber pads.
3. On-site labor.

Eagle Equipment reserves the right to make improvements and/or design changes to its equipment without any obligation to previously sold, assembled or fabricated equipment.

There is no other express warranty on the Eagle Automotive Lift equipment and this warranty is exclusive of and in lieu of all other warranties, expressed or implied, including all warranties of merchantability and fitness for a particular purpose.

To the fullest extent allowed by law, Eagle Equipment shall not be liable for loss of use, inconvenience, lost time, commercial loss or other incidental or consequential damages

Some States do not allow exclusion or limitation of consequential damages or how long an implied warranty lasts, so that the above limitations and exclusions may not apply. This warranty gives you specific legal rights and you may have other rights, which may vary from State to State.



Eagle Equipment, a division of **Standard Tools and Equipment Co.**, is a leading distributor of automotive repair and garage service equipment. Established in 1954, Eagle has provided quality equipment at competitive prices for 60 years, carrying a full line of automotive lifts: two-post lifts, four-post lifts, alignment lifts, scissors lifts, low-rise and mid-rise lifts, as well as models of movable service/storage lifts and our MOBILEMAN[®]. We also stock wheel service equipment including: wheel balancers, tire changers, and brake lathes. We offer a full line of parts, as well as technical support.

Visit us at: www.eagleequip.com



Established in 1979 to service the auto body and collision repair industry, **Tools USA** is operated by Standard Tools and Equipment Co., offering a wide variety of products for the auto body professional, collision shops and car hobbyist including auto lifts, frame machines, pulling posts, tire equipment, painting accessories, powder coating equipment, sandblasting equipment, paint booths and more. One of the largest paint booth manufacturers in the United States, Tools USA takes pride in building standard and custom engineered paint booths for all types of applications.

Visit us at: www.toolsusa.com



**Delivering Excellence to the Automotive and Painting Industries.
Every Product. Every Customer. Every Day.**

Standard Tools and Equipment Co. was founded in 1996 to provide tools and equipment to the automotive aftermarket industry. They began manufacturing paint booth systems in 1997. Having built over 10,000 paint spray booths for various industries, Standard Tools is among the country's largest suppliers. Tools USA was acquired in 1996 and became a part of the Standard Tools and Equipment family of brands. In 2005, Eagle Equipment, a 50-year-old company joined Standard Tools to provide automotive lifts and tire equipment to the repair industry.