

# **TPO-9 / TPO-9A / MX-9A**

**(9000LBS. CLEAR-FLOOR / ASSYMETRIC LIFTS)**

## **INSTALLATION AND OPERATION MANUAL**

**DATE INSTALLED:** \_\_\_\_\_  
**SERIAL #** \_\_\_\_\_

**(EAGLE)**

# INSTALLATION AND OPERATION MANUAL MODEL TPO-9/TPO-9A TWIN POST LIFTS

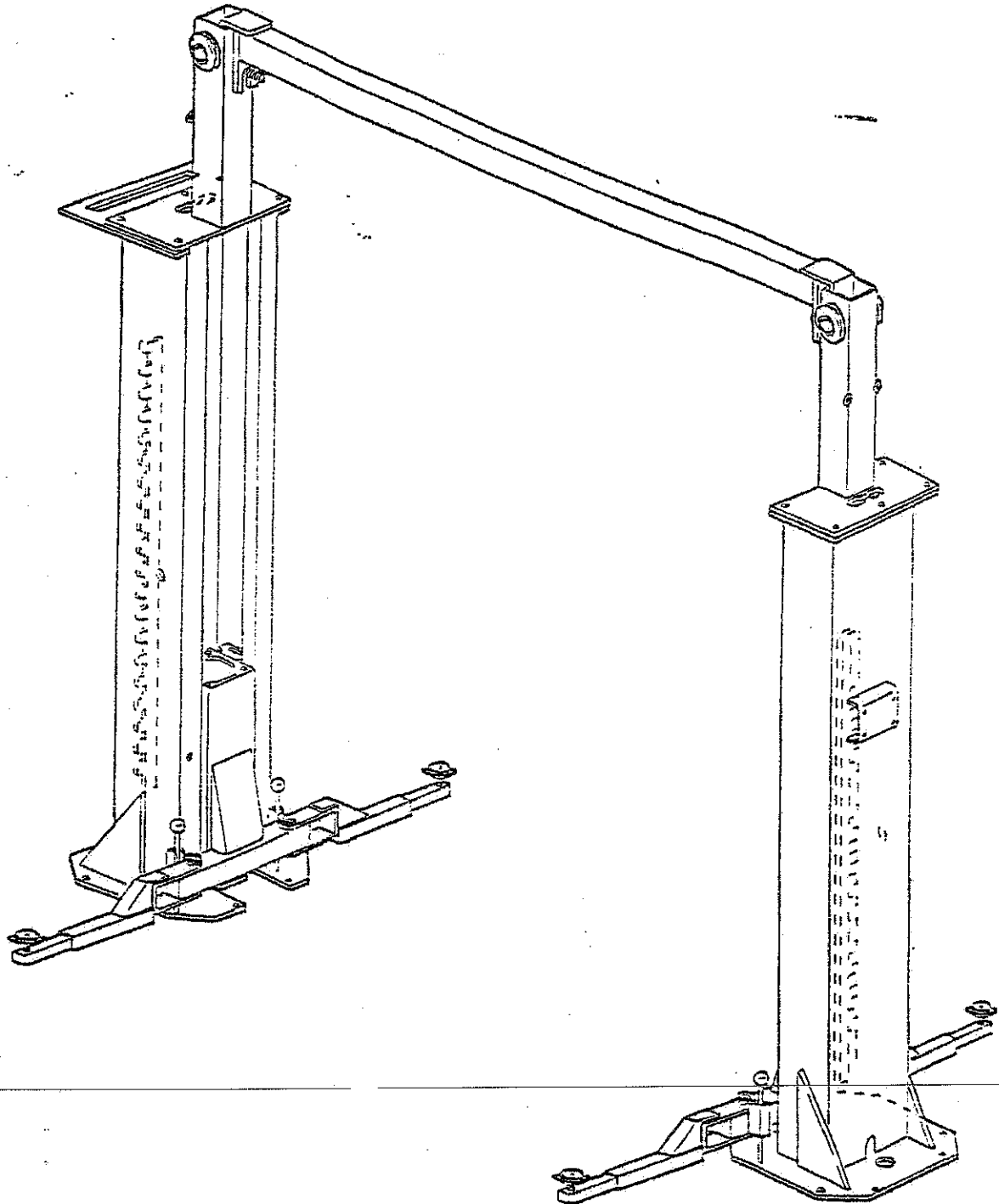

For technical support or service, call 800-536-0016

<b>Parts Checklist</b>
------------------------

Column Number	Item Description
2	33'9" x 3/8" cables with four nuts and washers
2	2.5" x 36" pistons with rollers
<b>On Top</b>	
1	Power unit
1	"O" parts box
4	Telescoping arms
1	Overhead beam
<b>In Parts Box</b>	
1	71" hose
1	334" hose
4	Arm pivot pins
4	Truck adapter
4	Scinups
12	Anchor bolts
1	Catalog
1	Small parts bag
1	TPO-9/TPO-9A instruction/operation manual
<b>Small Parts Bag</b>	
1	1/16" wire
2	Ferrules
2	6" pipe for piston
1	St thread T w/O-ring
2	90 F.M. elbow
4	5/16" 18 nylock nuts
4	5/16" 18 nuts
4	5/16" x 1" hex bolts
15	Shims
2	3/4" plugs

<b>INSTALLATION MANUAL CONTENTS</b> <b>TPO-9/TPO-9A</b>
--

***Parts Checklist******Notes about your Eagle® Lift******Installation Instructions***

- |         |   |
|---------|---|
| Step 1  | Measure lift area and check for defects                           |
| Step 2  | Cylinder assembly   |
| Step 3  | Position columns and uprights, level columns and install top beam |
| Step 4  | Install anchor bolts and re-level columns                         |
| Step 5  | Install and adjust cables   |
| Step 6  | Install power unit, hoses and cut-off cable                       |
| Step 7  | Install arms  |
| Step 8  | Install spinup pads and check height adapters                     |
| Step 9  | Electrical hook-up  |
| Step 10 | Test and adjust lift  |
- 

***Operation***

Learn proper operation and recheck lift components

***Maintenance Schedule***

Please read and follow the maintenance guide

***Troubleshooting Guide***

*Important notes about your Eagle® Lift...*

- Do not install this lift on any asphalt surface.
- Do not install this unit on any surface other than concrete conforming to minimum specifications.
- Do not install this lift over expansion joints or cracks. Check with building architect.
- Do not install this lift on a second floor with a basement beneath without written authorization from building architect.
- A good level floor is recommended for proper lift operation and installation. Cement should be a minimum of 4" thick and 3,000 psi tensile strength with steel or fiber mesh reinforcement.
- The lift is intended to raise the entire body of the vehicle only. Do not attempt to lift only part of the vehicle. Improper use of this equipment could result in damage to the lift, yourself or other property.
- The lift is intended to lift vehicles only. It is not designed to lift any person or equipment containing persons.
- All persons using this equipment should be qualified, responsible persons and should follow the operation and safety guidelines set forth in this manual.
- For specifications on concrete pads, please call for technical assistance.
- Improper installation can cause damage or injury. Manufacturer will assume no liability for loss or damage of any kind, expressed or implied, resulting from improper installation or use of this product. Read the installation and operation manual in its entirety before attempting to install the lift.

## Installation Manual TPO-9/TPO-9A

### Step 1: Measure lift area and check area for defects

The first step to any successful installation is to measure the bay for correct positioning of the lift. Measure the width of your doorway and divide it by two. This will give you the center of your doorway. Make a mark on the floor at the center of the doorway and measure from the side—wall to center mark. Note the distance and measure the same distance from the side wall at the front of the shop. Now snap a chalk line between the two marks—this is the center line for your lift.

Measure 71" (TPO-9A) or 68" (TPO-9) from the center line to each side of the center line at front and rear of the shop. Snap two more lines. These are your lift's outer dimensions (see Figure 1).

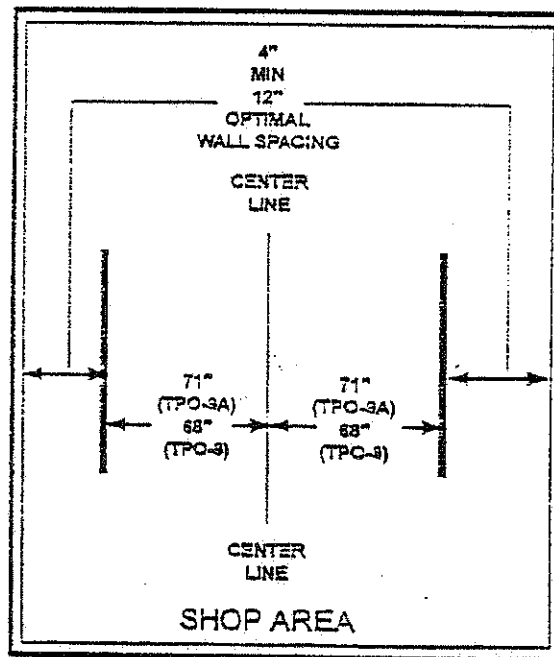

FIGURE 1

**NOTE:** If you have less than 4" between the wall and your outer dimension, you should move the lift over to allow for at least 4" of space. Eagle Equipment recommends 12" between the wall and the outer dimension, but where that is not possible, 4" is acceptable.

# Installation Manual TPO-9/TPO-9A

## Step 1: continued

Measure 13' (TPO-9A) or 11' 6" (TPO-9) from each side of the shop door, snap horizontal chalk line as shown. Use square and measure 12" from each side of previous chalk line on each side and snap horizontal chalk line as shown.

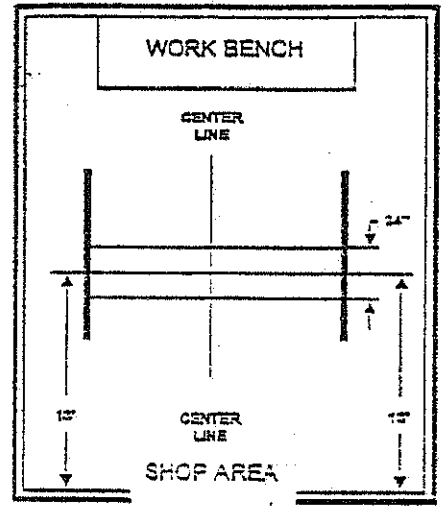

FIGURE 2A  
for  
TPO-9A

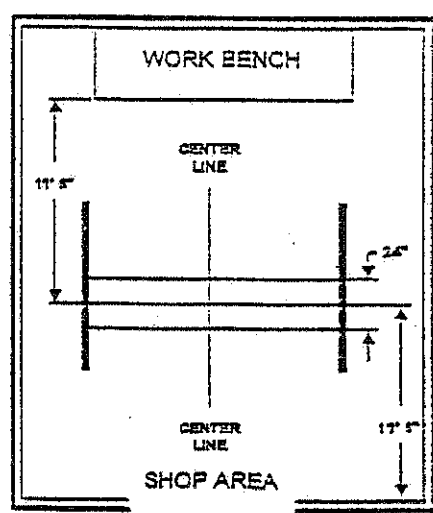

FIGURE 2B  
for  
TPO-9

# Installation Manual TPO-9/TPO-9A

## Step 2: Cylinder preparation

### Power unit side

With the column lying on the ground, remove the plastic (square head) plug.  
**NOTE: Some hydraulic cylinders may have two plugs. Use the plug WITHOUT FLOW RESTRICTOR.** Make sure the cylinder open port faces the opening in the back of the column. Stand the column up and assemble the nipple and the elbow fitting into the rear facing port using Teflon tape. Be sure the elbow fitting is facing up when tight (see Figure 3).

Repeat this process for the other side.

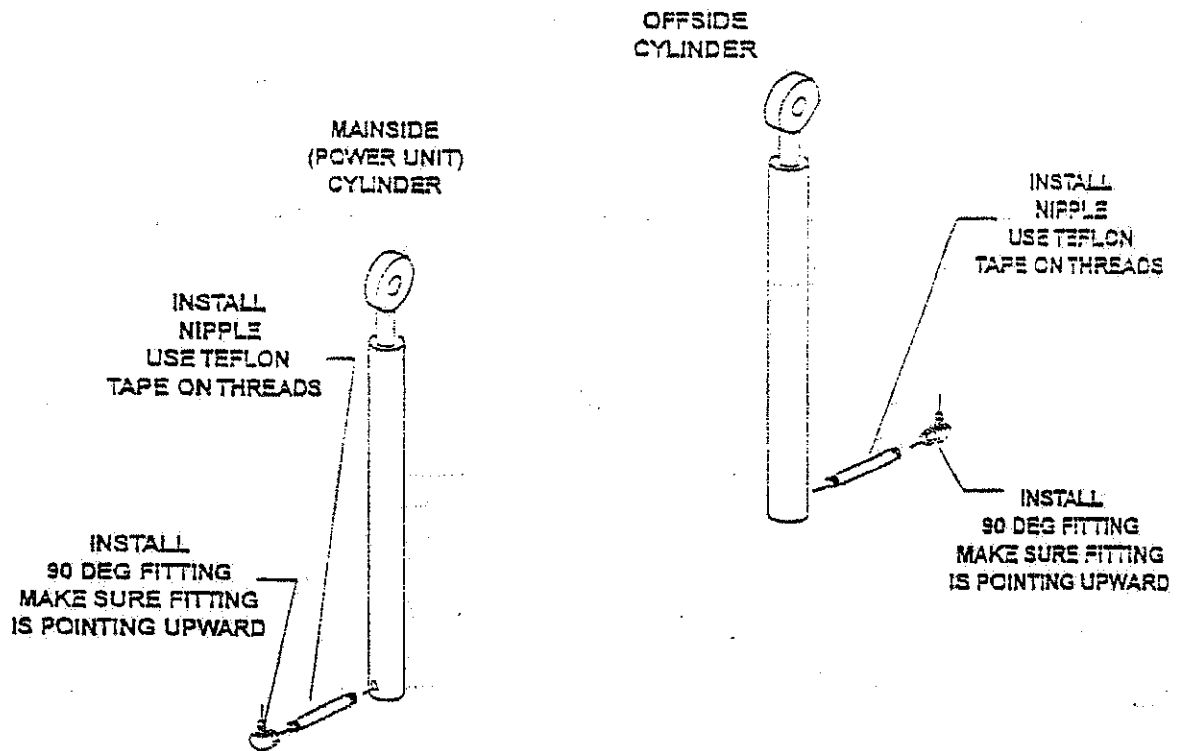

FIGURE 3



## Installation Manual TPO-9/TPO-9A

**Step 3:** Position columns and uprights, level columns and install top beam.

Examine the area where your lift is going. Check for large cracks in the floor, expansion joints and for overhead obstructions. If either column is going to sit across or on top of an expansion joint, you may need to move the lift to a different location.

**NOTE:** Bolt holes in the base plate should be at least 4" from any expansion joint or large crack. You will need at least 12' of unobstructed ceiling height.

Position the columns as shown in Figure 4. We recommend placing the power unit on the passenger side for ease of operation. Install the uprights so the threaded rods at the top face each other (the threaded rods should face the center line). Hand tighten for now. Using a four foot level,  $\frac{3}{4}$ " flat washers and shims provided, shim the columns level, front-to-back and side-to-side. Recheck the uprights to see that they are facing each other. If not, rotate the columns as needed and be sure to keep the base plates on the line.

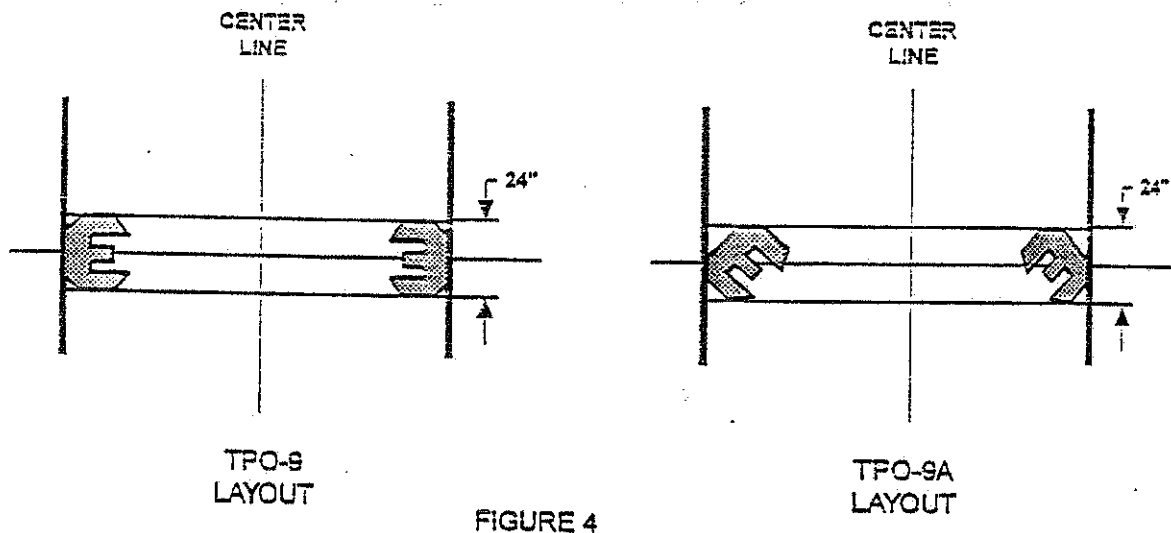

You are now ready to install Uprights and the Top Beam. Carry the beam to the top and hook each side to the top of an upright, guiding the bolt into the slot. Hand tighten nuts on the two bolts. (See Figure 5).

**Installation Manual  
TPO-9/TPO-9A**

Check the columns again to see if they are level and on the same baseline. You may need to hammer the columns using a rubber mallet, toward or away from center in order to get them level. Be sure to keep the columns even on the baseline. The outer dimensions are not as important at this point. Check top for space between the upright and top beam. You should have less than 1/2" between. If you have more, tighten nuts at top beam on both sides and re-level the columns.

**NOTE:** ⇒ *Double check everything now—next step is permanent!*

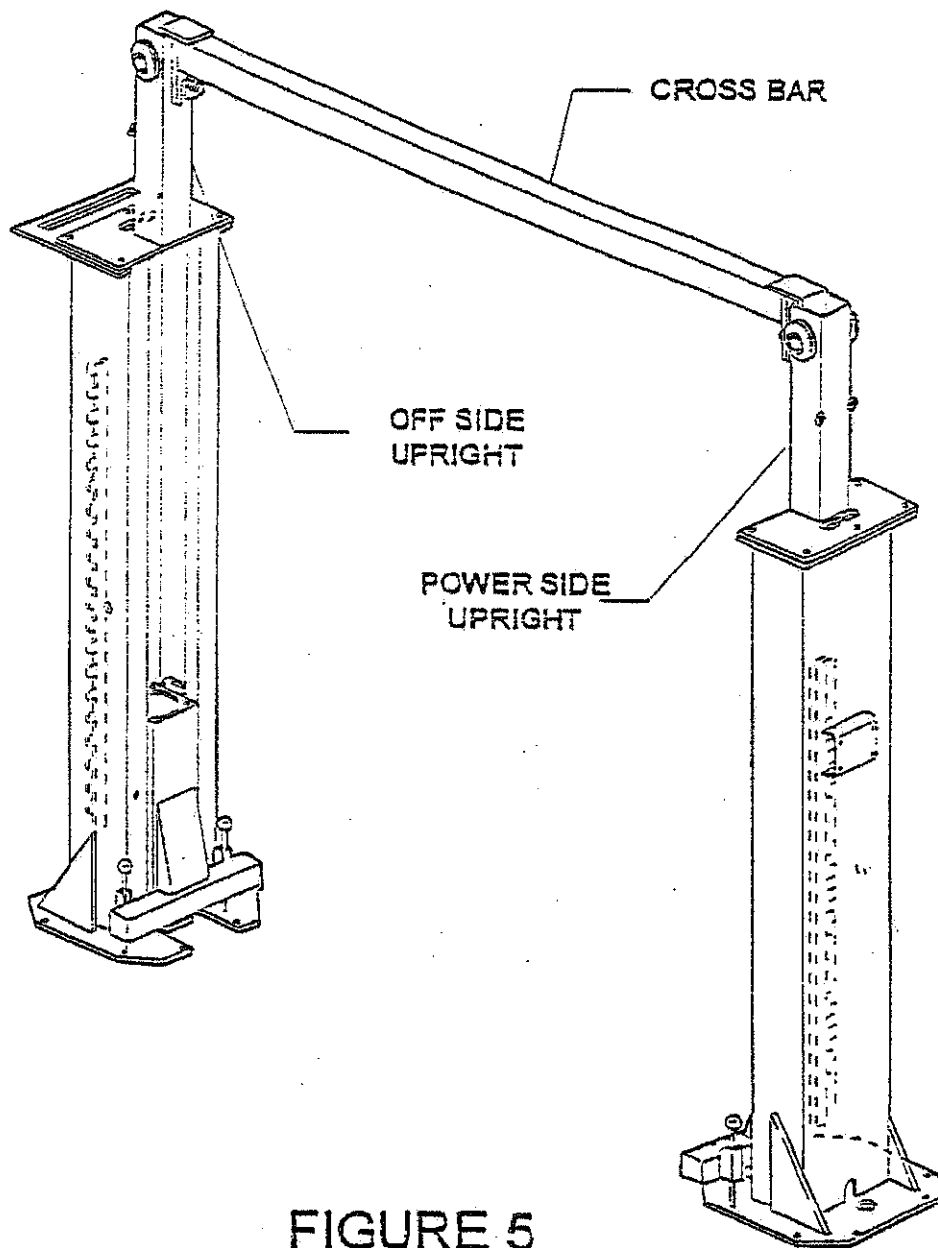
**FIGURE 5**

Installation Manual  
TPO-9/TPO-9A

**Step 4: Install anchor bolts and re-level columns.**

You will need a rotary hammer with a  $\frac{3}{4}$ " carbide masonry bit (most rental outlets carry them). Do not use a regular drill and bit!

Your floor must be a minimum of 4" thick and 2,400 psi concrete or better. Using your rotary hammer, drill twelve  $\frac{3}{4}$ " holes. Drill through the floor and hammer the anchor bolts in half-way (install the nut and flat washer on the bolt before placing them into the hole).

*NOTE: Be careful not to move the columns when drilling. One way to avoid this is to drill the holes and place the bolts one-at-a-time and save the inside hole for last.*

Recheck the level of each column and place shims around or beside each bolt and wherever there is space. Hammer the anchor bolts all the way down. Using a torque wrench, tighten the anchor bolts to 120 pounds of torque. Recheck the level of the columns. If the columns are off, loosen the anchors and use a pry bar to tilt the columns and shim as needed. Retighten and check again. Now tighten the bolts on the uprights. With all bolts tight and the columns as close to level as you can get, you will have a good solid installation and years of trouble-free service.

**Step 5: Install and adjust cables.**

Using two people, a fork-lift or shop crane, lift each carriage to the second or third lock. Allow each carriage to rest on the locks and measure each side to be sure they are at the same height. Unwrap the two large cables and separate them. Remove the four  $\frac{3}{4}$ " lock nuts and four  $\frac{3}{4}$ " thin flat washers. Place nuts and two flat washers on each carriage so they are easy to get at.

With your back to the door and standing between the posts, turn to your left. This will be called the "left" column. The side closest to the front wall will be the front end and the side closest to the door will be called the back.

Grab one cable end and run it over the left front pulley on the upright, down through the slot in the upright and through the hole in the corner of the carriage. Drop the end down on the floor, grab the end and put a flat washer and nut on it. Tighten the nut about  $\frac{2}{3}$  of the way on the rod. Grab the other end of the same cable and run it over the top of the front right pulley, down through the slot and straight down inside the carriage to the floor. Run the cable under the pulley on

Installation Manual  
TPO-9/TPO-9A

the bottom, up through the carriage and into the hole in the corner of the carriage. Pull the end through the hole. Make sure the other rod is now sitting in the hole in the other carriage. If you see less than 2" of rod sticking up, you can install the flat washer and nut, otherwise go back to the left side and tighten the nut more to take up the slack. Install the other cable in the same fashion, starting from the right side and running it over the back pulleys.

With both cables in place, you are ready to adjust. Start on the left side. With a pair of vice grips, grab the bottom of the shaft where threads are pointing up. Place an 1 1/16" deep socket on the nut and tighten it until the cable will give about 1" when you push on it. Repeat for opposite side. Both cables should now have the same tension. If locks don't hit at the same time on the way up tighten the side that hits first. Repeat this until locks engage at the same time. (See Figure 6)

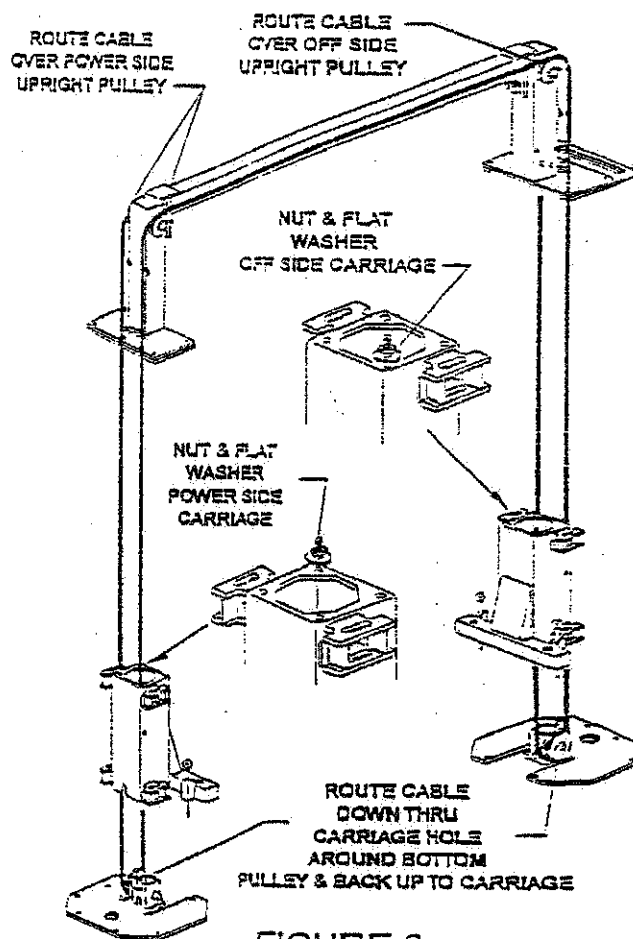
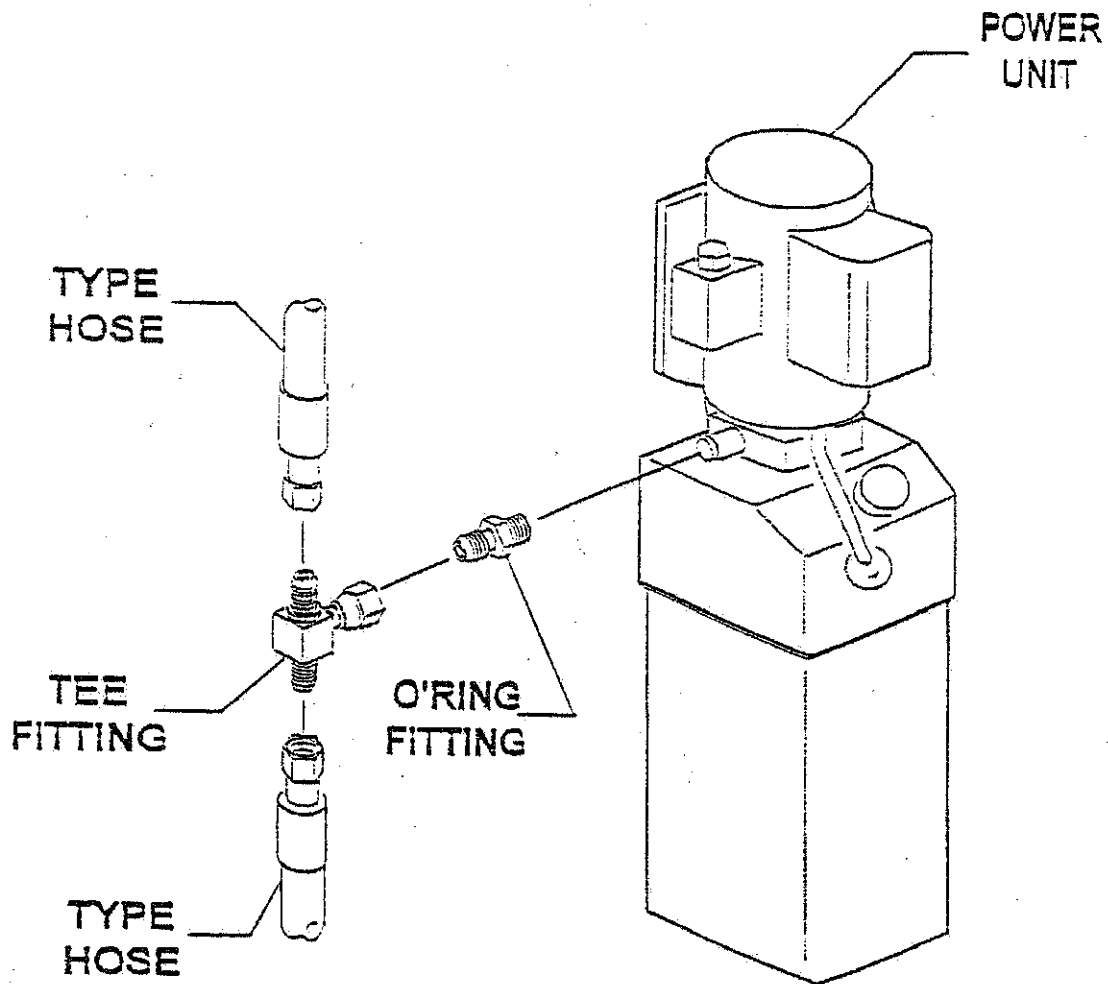

FIGURE 6

**NOTE:** ⇒ Do not over tighten cables. This will cause lift to lose carrying capacity and could damage the components

**Installation Manual  
TPO-9/TPO-9A****Step 6: Install power unit, hoses and cut-off cable**

Unpack the power unit from the box and remove the wood shipping board. Inspect the unit for damage before continuing. Remove the plastic cap from the 3/8" port on the side of the pump and install the "T" fitting found in the parts box. Screw in the "T" until the O-ring touches the pump and the ends are facing the top of the motor and the bottom of the tank. Then use an 11/16" wrench to tighten the locking nut and assure a good seal. Next use a screwdriver to pry off the 1" plastic cap from the tank. Place a funnel in the hole and fill the tank with 3.5 gallons of AW32 hydraulic oil.

**FIGURE 7A**

**Installation Manual  
TPO-9/TPO-9A**

Locate the four 5/16" x 1" bolts, four nuts and four lock nuts in the parts box. Place the four bolts in the four holes on the mounting plate on the column, then place the four nuts hand-tight onto the four bolts. Hang the power unit on the four bolts and put the four lock nuts in place to hold them. Tighten the four nuts first, then the lock nuts.

Unpack the long hose and connect one end to the fitting at the back of the left column. Run the hose up and over the top along the top beam and down through the other side to the top of the "T" fitting. You may wish to attach the hose to the top beam with wire ties or clamps. Attach the short hose to the bottom of the "T" and then to the bottom of the right column.

***Check all fittings to be sure they are tight to avoid leaks!***

Attach the 1/16" cable to the flat washer at the top of the left side upright using the small aluminum ferrules. Loop the cable through the ferrule, then through the washer and back through the ferrule. Crimp the ferrule to hold the cable. Pass the cable through the washer on the right side and down through the empty bolt hole in the middle of the upright. Loop the cable through the eye on the cutoff switch box, secure with ferrule. Make it as tight as you can without tripping the cutoff switch.

**Step 7:        Install arms**

Place the two long arms on the end of the square tube closest to the door, and the two short arms on the front. (On the model TPO-S all arms are one length.) Secure with steel pins.

**Step 8:        Spin-up pads and height adapters inspection**

Test to see if they screw up and down smoothly in the arm nut. Slip the four truck adapters over the pads to make sure they all fit. If you have one that doesn't fit, call the service line for a replacement.

Installation Manual  
TPO-9/TPO-9A

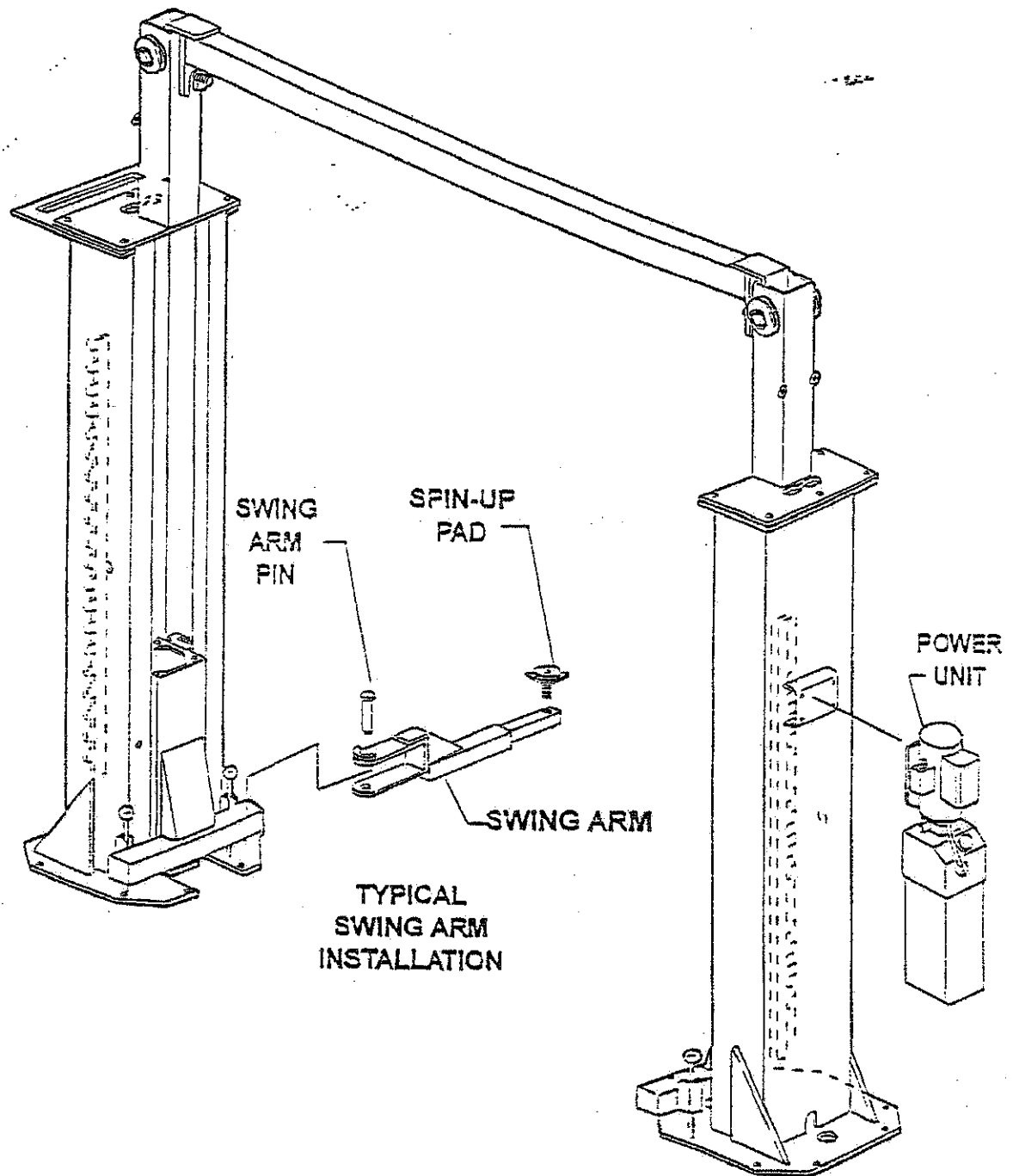

FIGURE 7B

**Installation Manual  
TPO-9/TPO-9A****Step 9: Electric hook-up**

The electrical hook-up should be done by a certified electrician. The power unit requires 208-220 volts on a 20 amp circuit breaker. It is recommended that you install a means of shutting down the power in close proximity to the power unit (a twist lock plug hung from the motor will be sufficient). The motor is factory pre-wired for proper power and rotation.

**Step 10: Test and adjust lift**

With the power properly hooked up and turned on, push the POWER button to raise the lift (the cylinders will take a little while to catch up to the chain; then the lift will begin to rise) *Check/Remove the plastic air vent covers on the 2-cylinders*. Raise the lift as high as it will go. Pull the key ring located near the bottom of each carriage to release the safety locks. Locate the lowering handle (Dump Valve) on the power unit. Pull and hold handle until the lift goes all the way down to the floor. Continue holding handle for at least 30 seconds to allow any air to escape from the hydraulic system. Once the lift is fully down, it's a good idea to have someone push down on the cylinders while you hold out the lowering handle. This will force out any additional air pockets. You only need to do this once.

Run the lift all the way up and down two more times. While running the lift, listen to the safety locks clicking. Each side should click within one second of each other or simultaneously. If they are not clicking together, you can adjust the cables to compensate either by tightening the side that is clicking first or loosening the side that is clicking last. Remember not to over-tighten cables—they should be firm.

**Operation: Learn proper operation and recheck life components**

On model TPO-9, swing front arms to the front and the rear arms to the rear. Once arms are in position, pull a car into the bay. A general rule of thumb is to stop the car with the center of the wheel base even with the center of the columns. On model TPO-9A, swing all arms to the rear, then pull a car into the bay. The general rule here is to align the steering wheel so that it is centered between the uprights.

Swing the four arms under the vehicle and position the pads under the appropriate lifting spots. (If you are not sure of the proper lifting points, you should check the vehicle's service manual or contact the vehicle manufacturer.)



Adjust the screw pads so they all hit their lift points at the same time. This will allow the car to be level when rising.

### Installation Manual TPO-9/TPO-9A

With the pads in their proper locations and no obstructions around the lift or vehicle, you may now press the button on the power unit to raise the vehicle.

Raise the vehicle so that the tires are only 6" off the ground. Walk to the back of the vehicle and push up and down on the bumper. The vehicle will rock, but should not at any time lose contact with the pads. If the vehicle is bounding off the pads or feels at all unstable, you should lower it back to the ground and reposition the pads to balance the load. Repeat this process until the vehicle is completely stable.

When the vehicle is stable, you may raise the lift all the way to the top. Listen to safeties and adjust if necessary.

*The proper operation of the lift requires that any time you raise a vehicle to work on it, you must lower the lift onto the safety locks. This is done by raising the vehicle to the desired height and lowering the lift until it stops on the next available lock. To lower vehicle, you must first raise the lift 1/2", release the safeties by pulling the key ring located near the bottom of each carriage, then pull the lowering handle. If you wish to lower the lift halfway and resume working on the vehicle, you must lower the vehicle 6" below the desired height, raise the lift again to engage the locks and then lower the lift onto the locks.*

**Never work under or near the lift without the locks engaged—the pump and cylinders are not intended to be a load-holding devices. Not using the locks will result in premature failure of the cylinders, pump and cables—and can cause serious property damage or personally injury. Failure to heed this warning will result in immediate termination of your warranty.**

**If you are unable to get the locks to perform correctly, call our technical support line at 800-535-0016 immediately.**

## Installation Manual TPO-9/TPO-9A

### Maintenance

Maintenance is the key to smooth, safe operation and longer life of your lift. Follow these guidelines on a regular basis to keep your lift running efficiently.

1. Your lift is only as good as the floor it is mounted on. Cracked or shallow concrete should be watched at all times. Although your floor may be thick enough according to manufacturers' specs, cracks and shallow spots can cause bolts to loosen and pull out of the floor. *All anchor bolts should be checked and retightened at least once a month.* Loose anchor bolts and weak cement are the number one cause of lift failure!
2. *Grease all the corners of the columns where the carriages run up and down.* The grease will do more good if you periodically clean off the old grease to get rid of any grit. A thin film of grease works better than thick blobs. Grease arm pins, if you are in a humid area or cables are exposed to salt from car melt, oil cables with a light oil so that it penetrates the cable windings to prevent oxidation of cables.
3. *You should oil the chains on your lift at least twice a year* to keep them from rusting and freezing up. Thirty-weight motor oil or motorcycle chain lube will be sufficient.
4. *All of the pulleys on your lift should be sprayed with a light oil* such as WD-40 or similar lubricant, two to three times a year.
5. *You should check for cracked or warped parts regularly and retighten any loose bolts.*
6. *Cables are an important part of your lift.* They keep both sides running equal to the other, allowing the safeties to catch together. If one side of your lift is running ahead of the other, most likely it is time to adjust your cables. Follow this simple procedure:
  - a. Raise the lift so the top of the carriage clears the chain and pulley.

- b. Notice the threaded rod and nut that stick out through the top of each carriage. These are your adjusting nuts.
- c. You will tighten the nut on the side that is lifting ahead of the other by holding the bottom of the threaded rod with a pair of vice-grips and turning the nut with a suitable wrench or socket.
- d. Run the lift up and down and determine if you need further adjustment. If so, repeat steps a through c.

*If at any time you're not sure of the safe operation of the lift, discontinue using it and call our technical support line for assistance.*

### Troubleshooting Guide

PROBLEM	POSSIBLE CAUSE	SOLUTION
Motor won't run	<ol style="list-style-type: none"> <li>1. Fuse or circuit breaker</li> <li>2. Incorrect voltage to motor</li> <li>3. Wiring connections</li> <li>4. Burned out micro switch</li> <li>5. Burned out motor windings</li> </ol>	<ol style="list-style-type: none"> <li>1. Replace blown fuse or reset circuit breaker</li> <li>2. Supply correct voltage to motor</li> <li>3. Check and repair or insulate all connections</li> <li>4. Replace micro switch</li> <li>5. Replace motor</li> </ol>
Motor runs but won't raise lift	<ol style="list-style-type: none"> <li>1. Motor runs in reverse direction</li> <li>2. Open lowering valve</li> <li>3. Pump is sucking air</li> <li>4. Suction tube is off pump</li> <li>5. Low oil level</li> </ol>	<ol style="list-style-type: none"> <li>1. Change motor rotation by reversing motor</li> <li>2. Repair or replace lowering valve</li> <li>3. Tighten all suction line fittings</li> <li>4. Replace suction tube</li> <li>5. Top-off tank</li> </ol>
Motor runs, raises lift, but not vehicle	<ol style="list-style-type: none"> <li>1. Motor is running on low voltage</li> <li>2. Debris in lowering valve</li> <li>3. Improper relief valve adjustment</li> <li>4. Overloading of lift</li> </ol>	<ol style="list-style-type: none"> <li>1. Supply correct voltage to motor</li> <li>2. Clean lowering valve</li> <li>3. Replace relief valve cartridge</li> <li>4. Check vehicle weight or balance load properly</li> </ol>
Lift settles down slowly	<ol style="list-style-type: none"> <li>1. Debris in check valve</li> <li>2. Debris in lowering valve</li> <li>3. External oil leaks</li> </ol>	<ol style="list-style-type: none"> <li>1. Clean check valve</li> <li>2. Clean lowering valve</li> <li>3. Check for and repair any leaks</li> </ol>
Anchor bolts won't stay	<ol style="list-style-type: none"> <li>1. Cement thickness/strength</li> </ol>	<ol style="list-style-type: none"> <li>1. Remove bad cement; pour new</li> </ol>

tight or are pulling out of floor	2. Insufficient Holes are too big for bolts	2. pad for lift per specs in manual Relocate lift using the proper size drill bit, or pour anchoring cement into holes to secure bolts.
Safety latches don't work	<ol style="list-style-type: none"> <li>1. Safety not adjusted properly</li> <li>2. Safety spring not connected</li> <li>3. Flat washer bent too far, squeezing release cable</li> <li>4. Safety latch is rusted or frozen</li> </ol>	<ol style="list-style-type: none"> <li>1. Raise lift until safety adjusting bolt appears in window, adjust as needed</li> <li>2. Reconnect safety spring</li> <li>3. Blend flat washer away from release cable until it moves freely</li> <li>4. Spray penetrating oil on latch and work the latch until it moves freely</li> </ol>
Cylinder whines or chatters	1. Dry or tight seal	1. Remove cylinder vent and spray Dura-lube or Teflon spray lube into cylinder
Oil squirts out of cylinder well	1. Bad seal	1. Replace seal on cylinder

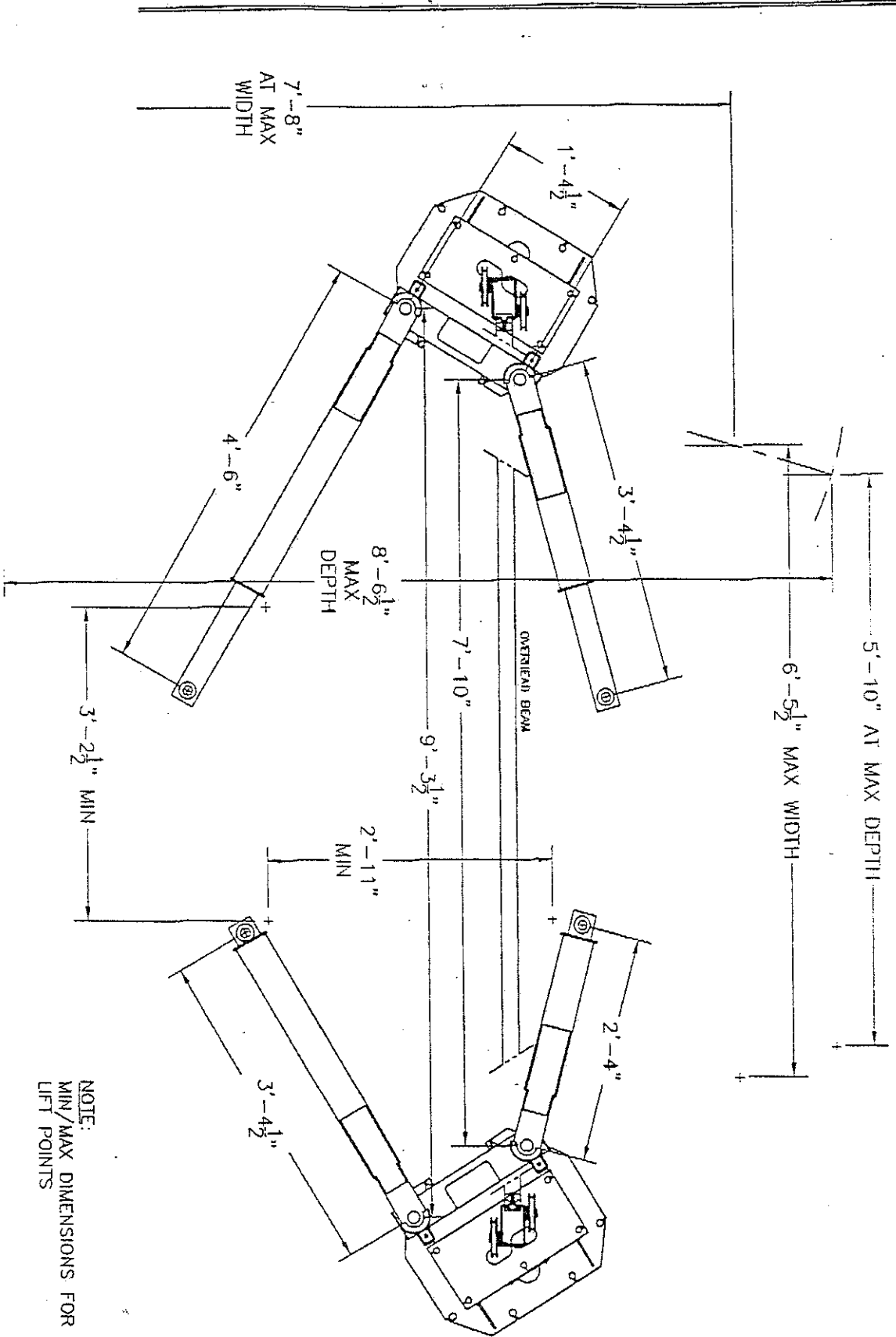

NOTE:  
MIN/MAX DIMENSIONS FOR RECTANGULAR  
LIFT POINTS

<b>EAGLE</b>		TOLERANCES: DIMS - 1/16" ANGLES - 1/16"	
Lift Manufacturing Corp.		DRAWN BY: TONY WARMACK	
925 North Broadway, Johnson, Texas 75008		DATE: 12/18/01	
TITLE: ARM REACH DIMENSIONS, TPO-9A/10A		SHEET: 1 OF 1	
PART #	REFERENCE	DWG #	REV. DATE
		R0057	-/-