



MTP-11A

(11000LBS. ASSYMETRIC OVERHEAD CLEAR FLOOR)

INSTALLATION AND OPERATION MANUAL

DATE INSTALLED: _____
SERIAL # _____

EAGLE EQUIPMENT 1-800-336-2776

INSTALLATION AND OPERATION MANUAL

MTP-11A LIFT

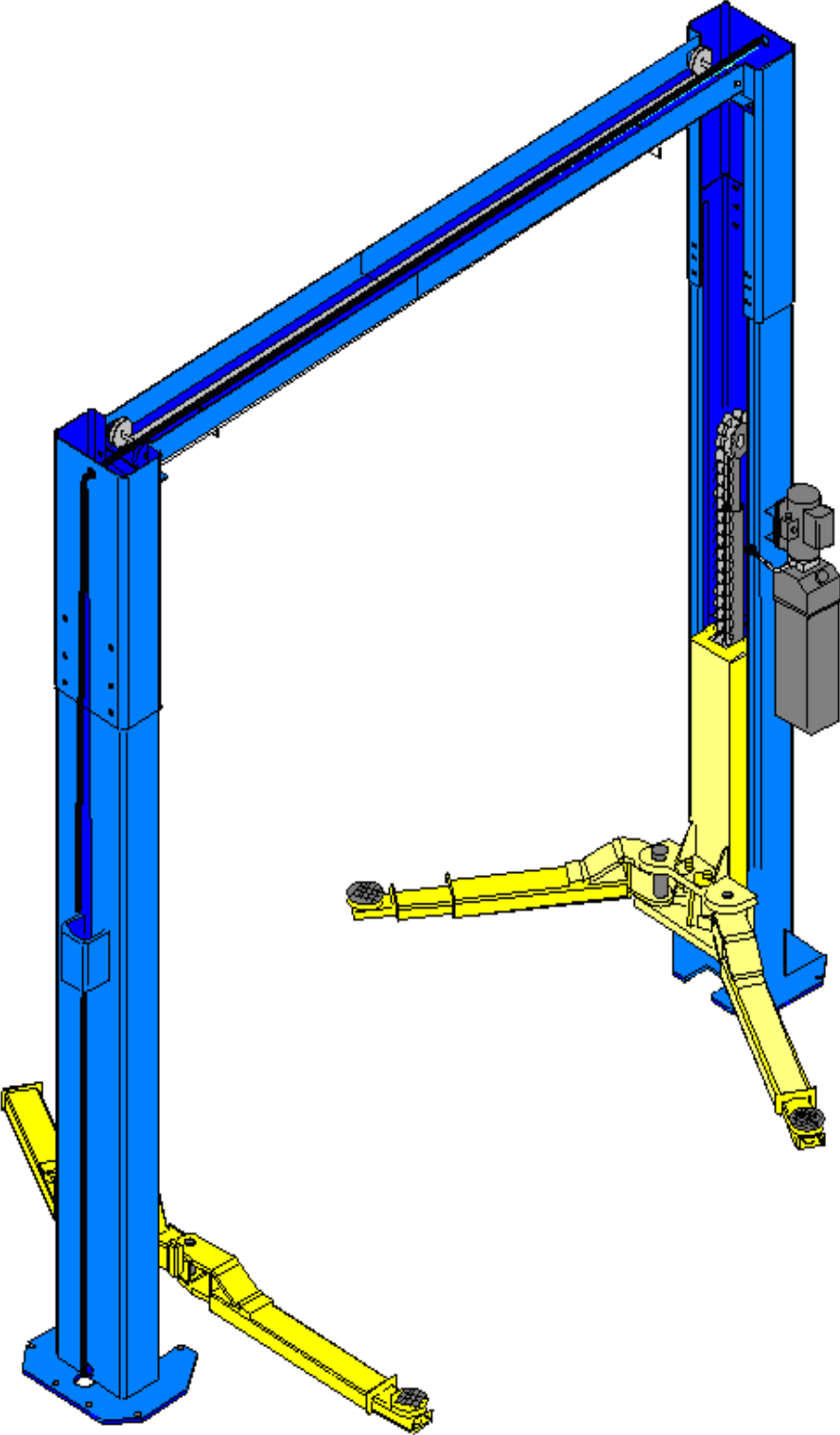

INSTALLATION MANUAL CONTENTS MTP-11A LIFT
--

Parts Checklist

Installation Instructions

- Step 1 Measure lift area and check for defects
- Step 2 Cylinder assembly
- Step 3 Position columns and uprights, level columns and install top beam
- Step 4 Install anchor bolts and re-level columns
- Step 5 Install and adjust cables
- Step 6 Install power unit, hoses and cut-off cable
- Step 7 Install arms
- Step 8 Install drop-in pads and check height adapters
- Step 9 Electrical hook-up
- Step 10 Test and adjust lift

Operation

Learn proper operation and recheck lift components

Maintenance Schedule

Please read and follow the maintenance guide

Troubleshooting Guide

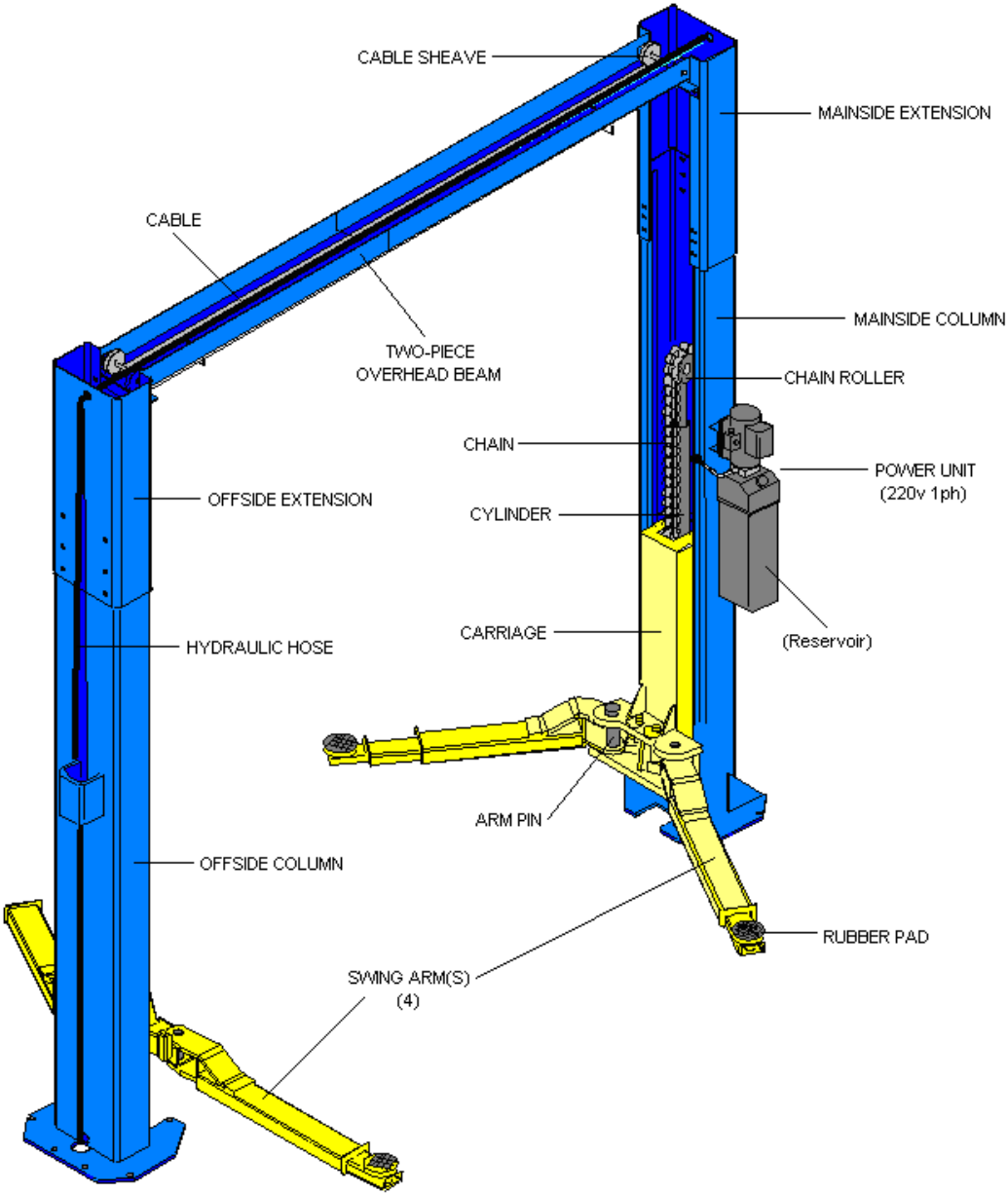

MTP-11A PARTS IDENTIFICATION

LIFT SPECIFICATIONS

CATEGORY	LOW	HIGH
CAPACITY	11,000 LB	11,000 LB
LIFTING TIME	55 SECONDS	55 SECONDS
OVERALL HEIGHT	141-1/2"	145-1/2"
OVERALL WIDTH	137-1/2"	137-1/2"
BETWEEN COLUMNS	110-3/4"	110-3/4"
DRIVE THROUGH HEIGHT SHUT-OFF	98-5/8"	98-5/8"
	136"	140"

Important notes

- Do not install this lift on any asphalt surface.
- Do not install this unit on any surface other than concrete conforming to minimum specifications.
- Do not install this lift over expansion joints or cracks. Check with building architect.
- Do not install this lift on a second floor with a basement beneath without written authorization from building architect.
- This lift is only as good as the floor you put it on. A good, level floor is recommended for proper lift operation and installation. Cement should be a minimum of 6" thick and 3,000 psi tensile strength with steel or fiber mesh reinforcement.
- The lift is intended to raise the entire body of the vehicle only. Do not attempt to lift only part of the vehicle. Improper use of this equipment could result in damage to the lift, yourself or other property.
- The lift is intended to lift vehicles only. It is not designed to lift any person or equipment containing persons.
- All persons using this equipment should be qualified, responsible persons and should follow the operation and safety guidelines set forth in this manual.
- For specifications on concrete pads, please call for technical assistance.
- Improper installation can cause damage or injury. Manufacturer will assume no liability for loss or damage of any kind, expressed or implied, resulting from improper installation or use of this product. **Read the installation and operation manual in its entirety before attempting to install the lift.**

Step 1: Measure lift area and check area for defects

The first step to any successful installation is to measure the bay for correct positioning of the lift. Measure the width of your doorway and divide it by two. This will give you the center of your doorway. Make a mark on the floor at the center of the doorway and measure from the side-wall to center mark. Note the distance and measure the same distance from the side wall at the front of the shop. Now snap a chalk line between the two marks -- this is the center line for your lift.

Measure **68-3/4"** from the center line to each side of the center line at front and rear of shop. Snap two more lines. These are your lift's outer dimensions (see Figure 1).

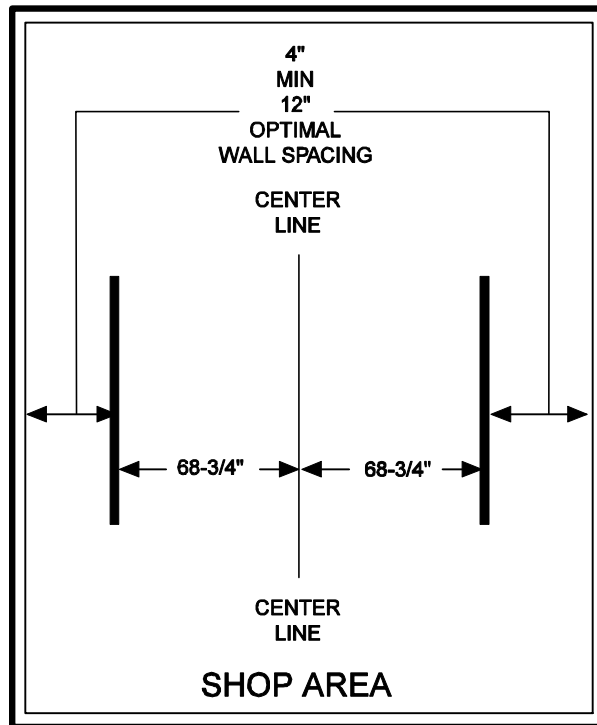

FIGURE 1

NOTE: If you have less than 4" between the wall and your outer dimension, you should move the lift over to allow for at least 4" of space. Manufacturer recommends 12" between the wall and the outer dimension, but where that is not possible, 4" is acceptable.

Step 1: (continued)

Measure 12' from each side of the shop door, snap horizontal chalk line as shown. Use square and measure 12" from each side of previous chalk line on each side and snap horizontal chalk line as shown

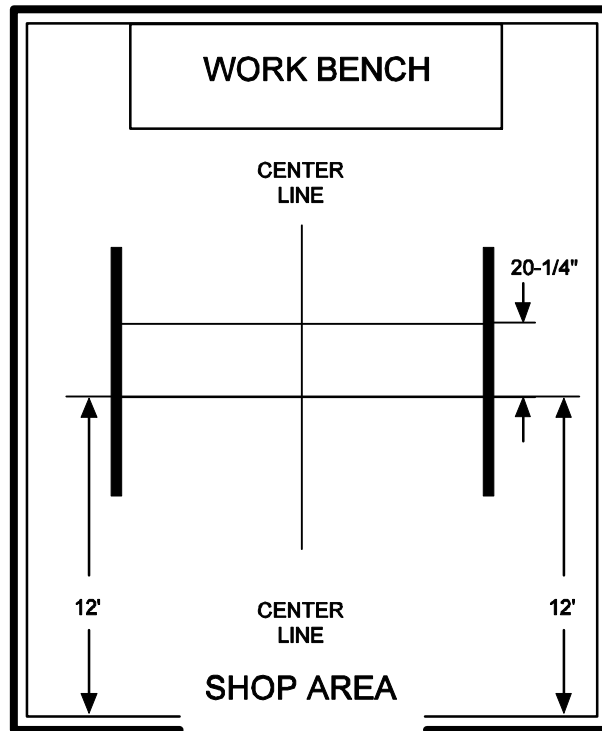

FIGURE 2

NOTE:
BEFORE ERECTING COULMNS,
CHECK FOR "SLOP" IN CARRIAGE ASSEMBLIES
AND SHIM IF NECESSARY.

(See Carriage Shimming Procedure at the back of this manual for details.)

Step 2: Assemble Extensions to each column

With the column laying down, slide Extension onto column and line up holes. Use 3/8 x 3/4" long bolts, washer and lock washers. Tighten. (see Figure 3.)

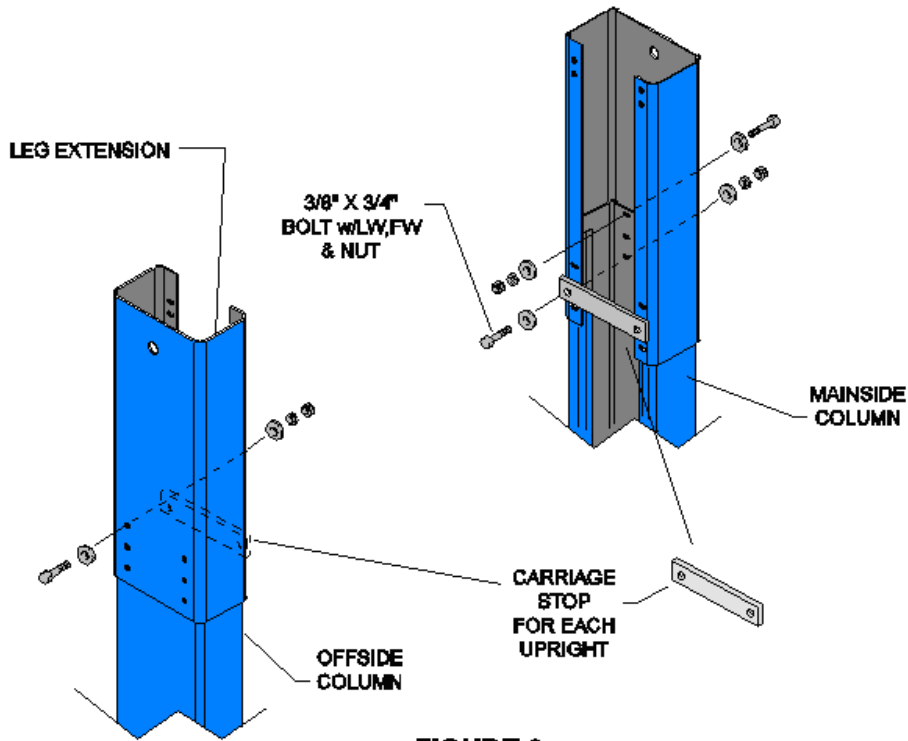

FIGURE 3

Step 3: Assemble Cable Lock Pulley to each extension

Assemble Cable lock bracket to extensions using hardware supplied.

Step 4: Position columns and level.

Examine the area where your lift is going. Check for large cracks in the floor, expansion joints and for overhead obstructions. If either column is going to sit across or on top of an expansion joint, you may need to move the lift to a different location.

NOTE: Bolt holes in the base plate should be at least 4" from any expansion joint or large crack. You will need at least 12' of unobstructed ceiling height.

Position the columns as shown in Figure 6. Using a four foot level and shims provided, shim the columns level, front-to-back and side-to-side.

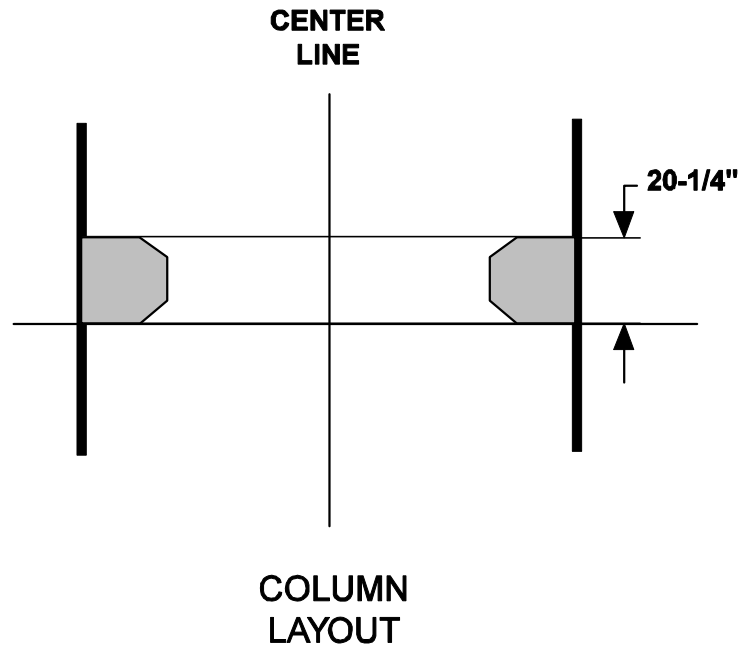

FIGURE 6

Step 5: Install anchor bolts and re-level columns.

You will need a rotary hammer with a $\frac{3}{4}$ " carbide masonry bit (most rental outlets carry them). Do not use a regular drill and bit!

Your floor must be a minimum of **5" thick and 3,000 psi** concrete or better. Using your rotary hammer, drill twelve $\frac{3}{4}$ " holes. Drill through the floor and hammer the anchor bolts in half-way (install the nut and flat washer on the bolt before placing them into the hole).

NOTE: Be careful not to move the columns when drilling. One way to avoid this is to drill the holes and place the bolts one-at-a-time and save the inside hole for last.

Recheck the plum & level of each column and place shims around or beside each bolt and wherever there is space. Hammer the anchor bolts all the way down. Using a torque wrench, tighten the anchor bolts to **110 foot-pounds** of torque **NOTE: Reset to 120 foot-pounds in 2-days**. Recheck the level of the columns. If the columns are off, loosen the anchors and use a pry bar to tilt the columns and shim as needed. Retighten and check again. Now tighten the bolts on the uprights. With all bolts tight and the columns as close to level as you can get, you will have a good solid installation and years of trouble-free service.

NOTE: It is often a good idea to leave one column free-standing until installation is complete, to ensure proper installation and operation of unit. Anchor one (1) column to secure lift, then route cables and hoses. Run lift without vehicle on it, to ensure smooth operation and that there is no binding. Then anchor second column.

Step 6: Install and adjust cables.

Using two people, a fork-lift or shop crane, lift each carriage to the first or second safety lock position. Allow each carriage to rest on the locks and measure each side to be sure they are at the same height. Unwrap the two large cables and separate them. Remove the four $\frac{3}{4}$ " lock nuts and four $\frac{3}{4}$ " thin flat washers. Place nuts and two flat washers on each carriage so they are easy to get at.

Route cables per diagram. See figure 7

Four **full height** settings, cable will attach to the flange located about 6" above the carriage top.

For **low height** settings, cable will pass through the flange and attach to the hole in the carriage top.

Step 6: Install and adjust cables. (CONTINUED)

With both cables in place, you are ready to adjust. Start on the left side. With a pair of vice grips, grab the bottom of the rod whose threads are pointing up. Place a deep socket on the nut and tighten it until the opposite side raises $\frac{1}{4}$ ". Tighten the other side the same way until it comes back down $\frac{1}{4}$ " and then give it one full turn. Both cables should now have the same tension.

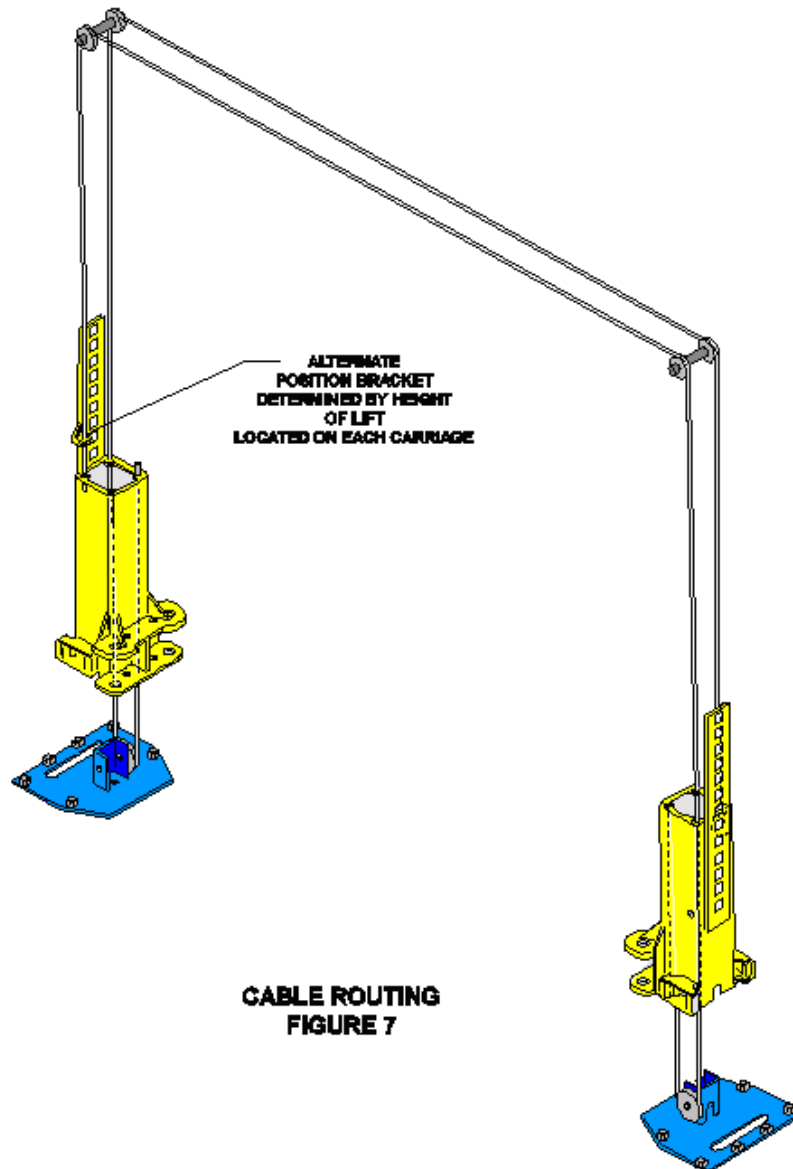

NOTE: ⇒ Do not over-tighten cables. This will cause lift to lose carrying capacity and could damage the components

Step 7: Install Single Point Lock Cable

Install Single point lock cable as shown. Route from Offside lock pulley up to pulley on Extension across to other pulley down to Mainside lock pulley. See Figure 8.

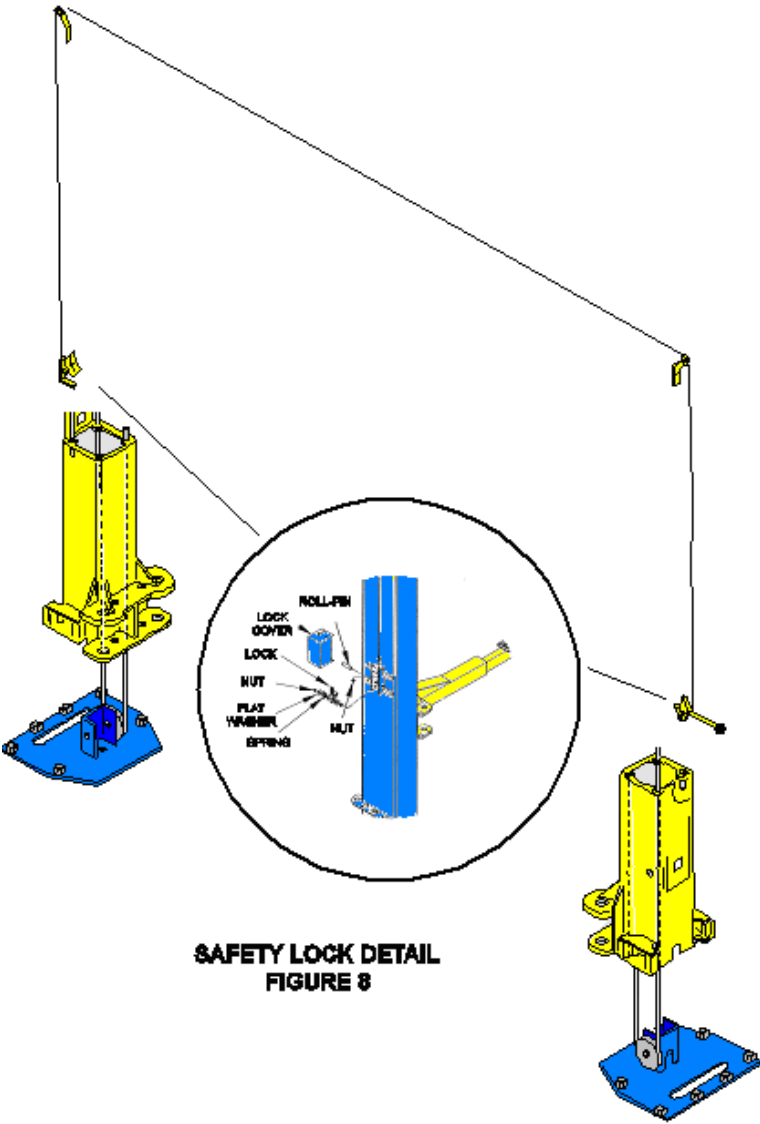

Step 8: Assemble Locking Mechanism

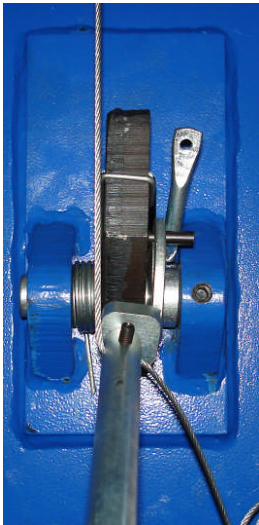
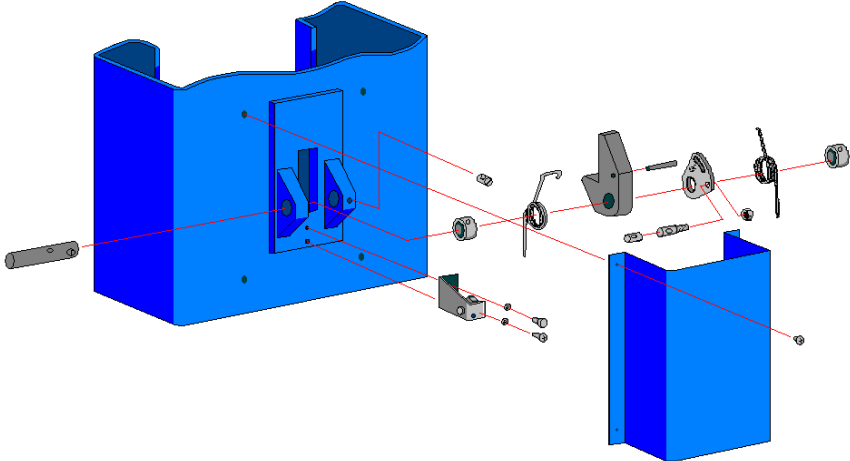
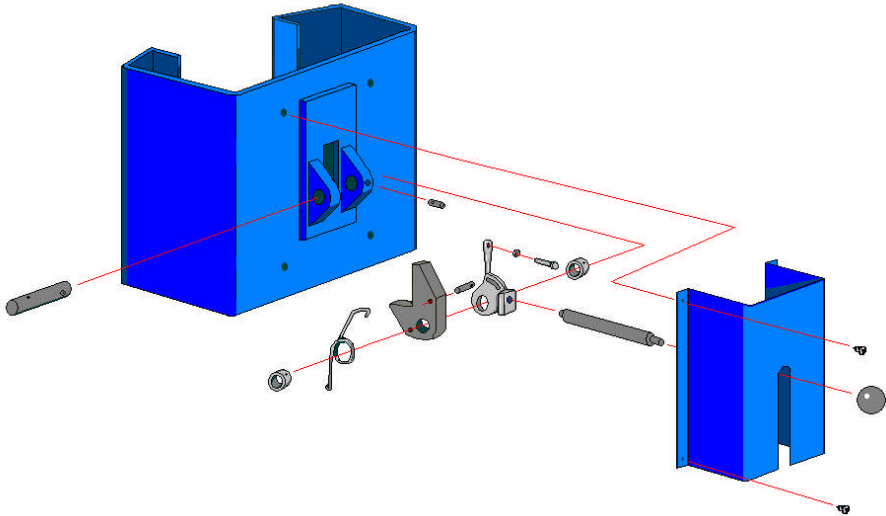

Mainside Lock Installed

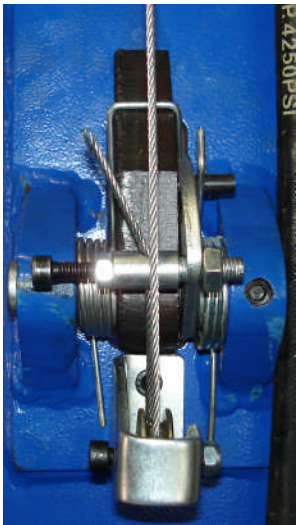

Offside Lock Installed

Step 9: Install Cut-off bar and limit switch.

Install Limit Switch and cut-off bar as shown.

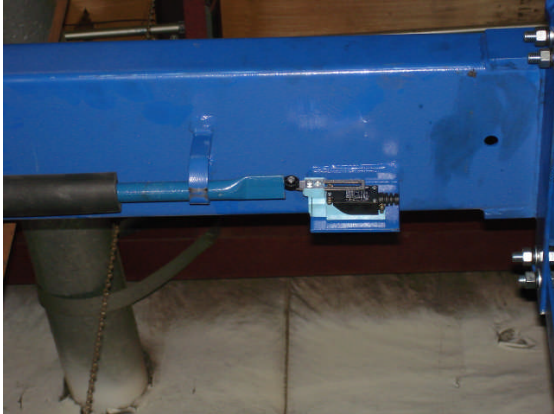
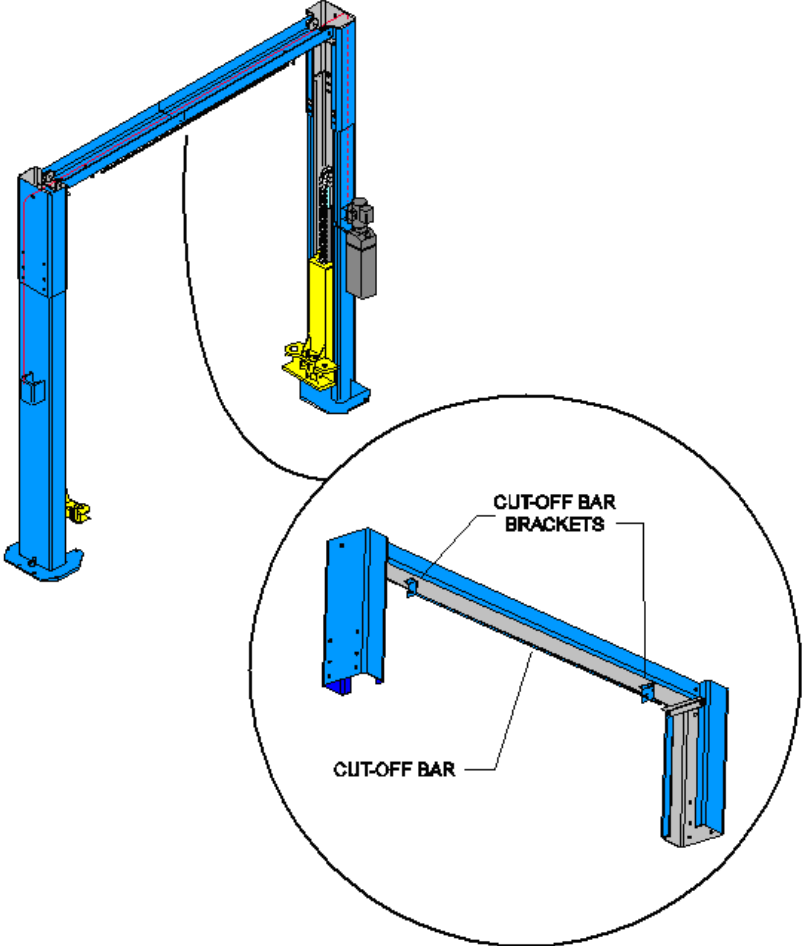

Step 10: Install power unit and hoses.

Remove the power unit from the box. Inspect the power unit for damage before continuing.

Locate the four 5/16" x 1" bolts, four nuts and four lock nuts in the parts box. Place the four bolts in the four holes on the mounting plate on the column, then place the four nuts hand-tight onto the four bolts. Hang the power unit on the four bolts and put the four lock nuts in place to hold them. Tighten the four nuts first, then the lock nuts.

Remove the plastic cap from the 3/8" port on the side of the pump and install the o-ring fitting found in the parts box. Screw in the "T" fitting until the O-ring touches the pump and the ends are facing the top of the motor and the bottom of the tank. Then use a 11/16" wrench to tighten the locking nut and assure a good seal. Next unscrew plastic cap from the tank. Place a funnel in the hole and fill the tank with AW32 (10W) hydraulic oil. (Figure 10.)

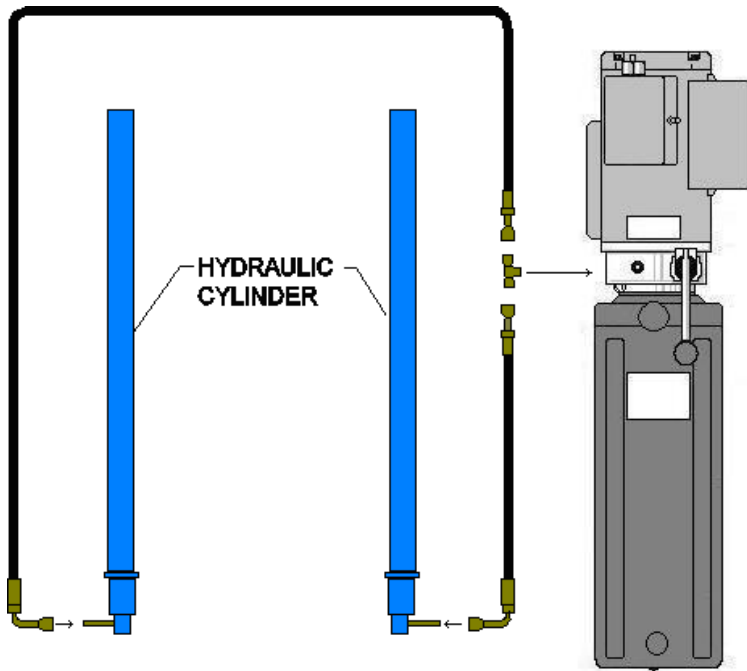

**HYDRAULIC HOSE ROUTING
FIGURE 10**

Step 10: Install power unit and hoses. (CONTINUED)

Locate the four 5/16" x 1" bolts, four nuts and four lock nuts in the parts box. Place the four bolts in the four holes on the mounting plate on the column, then place the four nuts hand-tight onto the four bolts. Hang the power unit on the four bolts and put the four lock nuts in place to hold them. Tighten the four nuts first, then the lock nuts.

Unpack the long hose and connect one end to the fitting at the back of the offside tower base. Run the hose up and over the top thru hole in extensions. Connect the short hose to fitting at back of mainside tower base. Connect both hoses to T-fitting at power unit. See figures 10 & 11.

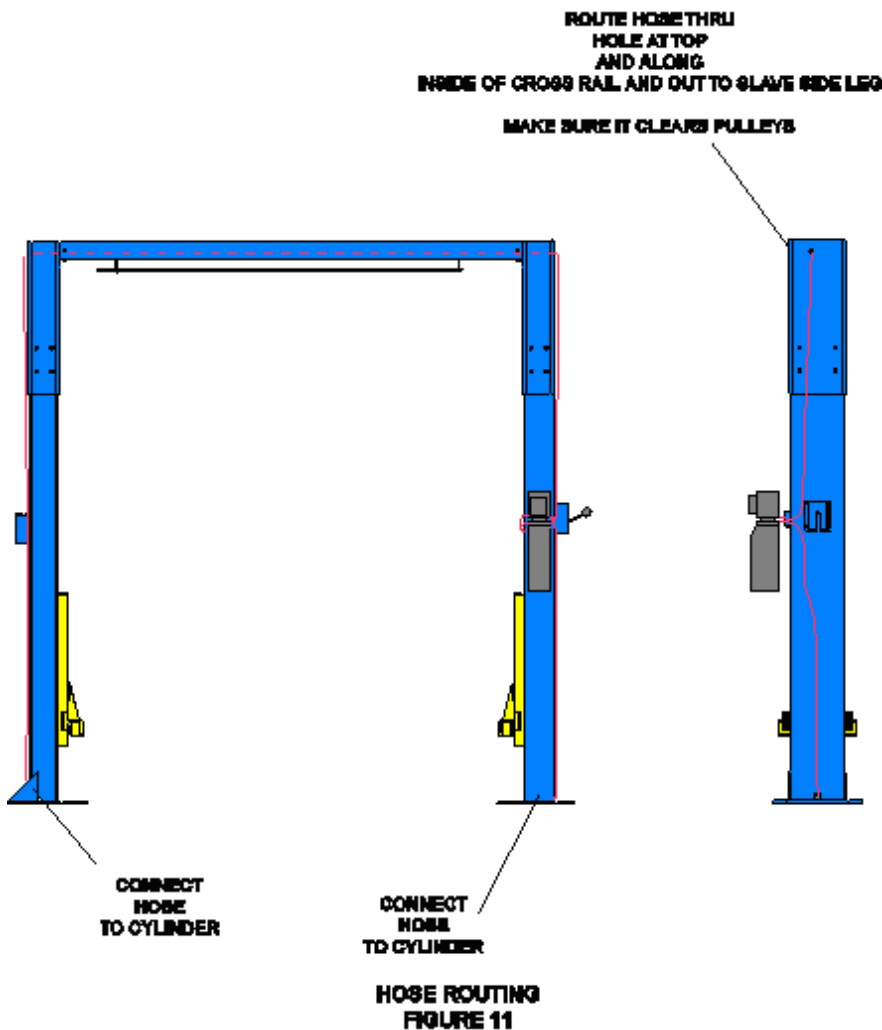

Check all fittings to be sure they are tight to avoid leaks!

Step 11: Install Swing arms and Pads

Place the two long arms on the end of the square tube closest to the door, and the two short arms on the front. **Note that the two front arms are different.** Secure with steel pins.

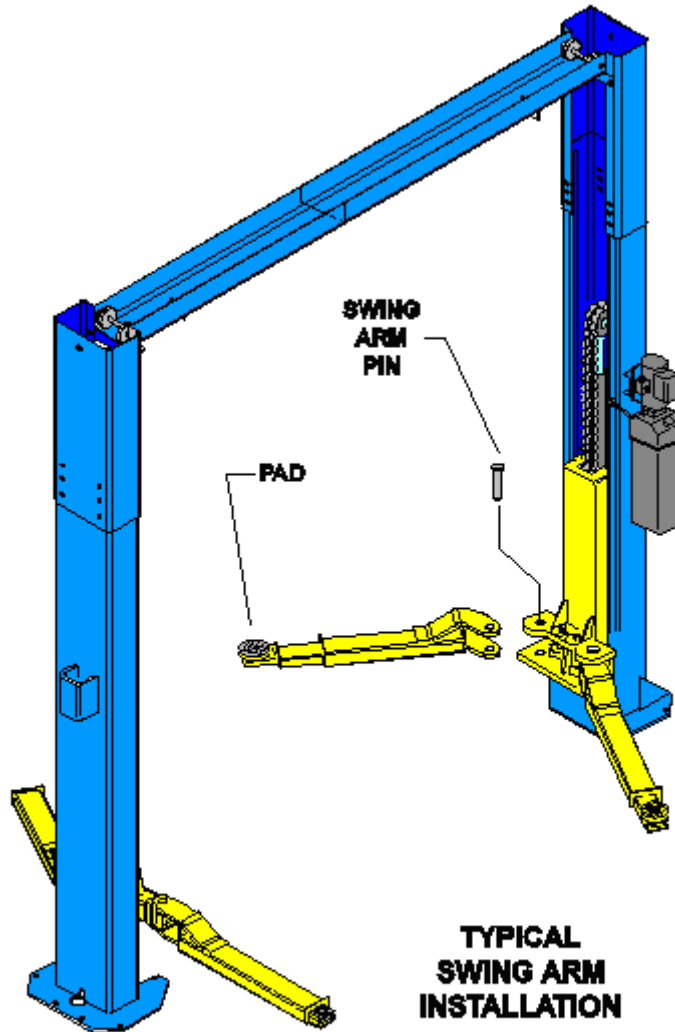

FIGURE 12

Adjust the swing-arm locks as necessary to ensure proper engagement. Teeth and gears should make solid contact.

Install the four drop-in pads into sockets at end of each arm.

Step 12: Electric hook-up.

Wiring the Lift

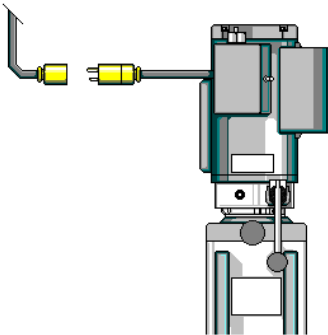

WARNING  **FINAL ELECTRICAL CONNECTION MUST BE MADE BY A CERTIFIED ELECTRICIAN.**  **WARNING**

1] The power unit requires a 208-220v, 20amp circuit breaker; and typically comes with a “pig-tail” already attached and wired to the motor. It is recommended that a twist-lock connection be installed at this pig-tail as an emergency disconnect (Fig. 15).



(Fig. 15)

2] Power Unit comes pre-wired with a pig-tail attached. Wiring may vary, depending on the Power Unit. Wire the power unit as shown below, depending on configuration for your Power Unit (Fig. 16a or 16b).

WARNING  **DO NOT ASSUME WIRING COLORS OR LABELS ARE ACCURATE. VERIFY THE WIRING INSIDE SWITCH BOX OF POWER UNIT IS ROUTED CORRECTLY TO PROVIDE 220v/20@/SINGLE PHASE TO THE SWITCH AND MOTOR, WITH PROPER GROUND.**  **WARNING**

SWITCH BOX

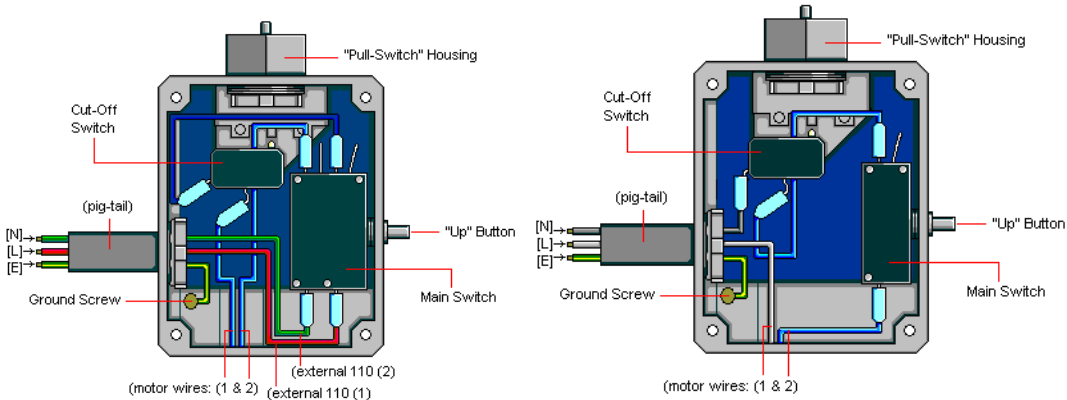

(Fig. 16a)

(Fig. 16b)

Step 12: Electric hook-up (continued)

Some Power Units come with a standard pull-style cut-off switch not used in this application (fig. D). Remove this from the Power Unit switch-box.

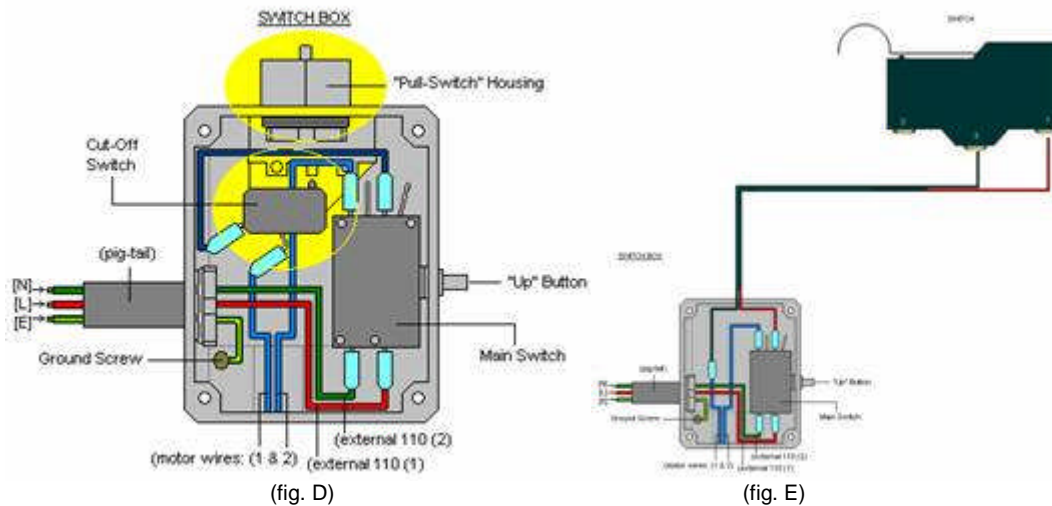

Hardwire the wire from the Overhead Switch into the Power Unit switch-box, to where the original switch had been connected.

Step 13: Test and adjust lift.

With the power properly hooked up and turned on, push the button to raise the lift. (The cylinders will take a little while to catch up to the chain; then the lift will begin to rise). Raise the lift as high as it will go. Push and hold the safety release lever near the power unit to release the safety locks. Locate the lowering handle on the power unit. Depress and hold handle until the lift goes all the way down to the floor. Continue holding handle for at least 30 seconds to allow any air to escape from the hydraulic system. Once the lift is fully down, it's a good idea to have someone push down on the cylinders while you hold out the lowering handle. This will force out any additional air pockets. You only need to do this once.

Run the lift all the way up and down two more times. While running the lift, listen to the safeties clicking. Both sides should click in sync with each other. If they are not clicking together, you can adjust the cables to compensate either by tightening the side that is clicking first or loosening the side that is clicking last. **Do not over-tighten cables**—there should be $\frac{3}{4}$ - 1" of deflection ("play").

Operation: Learn proper operation and recheck life components

Swing all arms to the rear, then pull a car into the bay. The general rule is to pull the vehicle in until the steering wheel is in-line with the posts.

Swing the four arms under the vehicle and position the pads under the appropriate lifting spots. (If you are not sure of the proper lifting points, you should check the vehicle's service manual or contact the vehicle manufacturer.) Use the drop-in height adapters if needed, so they all hit their lift points at the same time. This will allow the car to be level when rising.

With the pads in their proper locations and no obstructions around the lift or vehicle, you may now press the button on the power unit to raise the vehicle.

Raise the vehicle so that the tires are only 6" off the ground. Walk to the back of the vehicle and push up and down on the bumper. The vehicle will rock, but should not at any time lose contact with the pads. If the vehicle is bounding off the pads or feels at all unstable, you should lower it back to the ground and reposition the pads to balance the load. Repeat this process until the vehicle is completely stable. ***Verify the swing-arm locks are correctly and solidly engaged.***

When the vehicle is stable, you may raise the lift all the way to the top.



WARNING

When working on a vehicle



WARNING

ALWAYS make sure that ALL LOCKS are engaged.

NEVER work beneath a vehicle without it resting securely on the carriage locks.

Ensure that the swing arm locks are properly engaged.

The proper operation of the lift requires that any time you raise a vehicle to work on it, you must lower the lift onto the safety locks. This is done by raising the vehicle to the desired height and lowering the lift until it stops on the next available lock. To lower vehicle, you must first raise the lift 1" or 2", release the safeties by pushing and holding the safety release handle, and depressing and holding the hydraulic lowering handle on the power unit.

Never work under or near the lift without the locks engaged and resting on the safety stops—the pump is not intended to be a load-holding device. Not using the locks will result in premature failure of the cylinders, pump and cables—and can cause serious property damage or personally injury. Failure to heed this warning will result in immediate termination of your warranty.

If you are unable to get the locks to perform correctly, call our technical support line

Maintenance

Maintenance is the key to smooth, safe operation and longer life of your lift. Follow these guidelines on a regular basis to keep your lift running efficiently.

1. Your lift is only as good as the floor it is mounted on. Cracked or shallow concrete should be watched at all times. Although your floor may be thick enough according to manufacturers' specs, cracks and shallow spots can cause bolts to loosen and pull out of the floor. **All anchor bolts should be checked and retightened at least once a month.** Loose anchor bolts and weak cement are the number one cause of lift failure!
2. **Grease all the corners of the columns where the carriages run up and down.** The grease will do more good if you periodically clean off the old grease to get rid of any grit. A thin film of grease works better than thick blobs.
3. **You should oil the chains on your lift at least twice a year** to keep them from rusting and freezing up. Thirty-weight motor oil or motorcycle chain lube will be sufficient.
4. **All of the pulleys on your lift should be sprayed with a light oil** such as WD-40 or similar lubricant, two to three times a year.
5. **You should check for cracked or warped parts regularly and re-tighten any loose bolts.**
6. **Cables are an important part of your lift.** They keep both sides running equal to the other, allowing the safeties to catch together. If one side of your lift is running ahead of the other, most likely it is time to adjust your cables. Follow this simple procedure:
 - a. Raise the lift so the top of the carriage clears the chain and pulley.
 - b. Notice the threaded rod and nut that stick out through the top of each carriage. These are your adjusting nuts.
 - c. You will tighten the nut on the side that is lifting ahead of the other by holding the bottom of the threaded rod with a pair of vice-grips and turning the nut with a suitable wrench or socket.
 - d. Run the lift up and down and determine if you need further adjustment. If so, repeat steps a through c.

If at any time you're not sure of the safe operation of the lift, discontinue using it and call our technical support line for assistance.

Troubleshooting Guide

PROBLEM	POSSIBLE CAUSE	SOLUTION
Motor won't run.	<ol style="list-style-type: none"> 1. Fuse or circuit breaker 2. Incorrect voltage to motor 3. Wiring connections 4. Burned out micro switch 5. Burned out motor windings 	<ol style="list-style-type: none"> 1. Replace blown fuse or reset circuit breaker 2. Supply correct voltage to motor 3. Check and repair or insulate all connections 4. Replace micro switch 5. Replace motor
Motor runs but won't raise lift	<ol style="list-style-type: none"> 1. Motor runs in reverse direction 2. Open lowering valve 3. Pump is sucking air 4. Suction tube is off pump 5. Low oil level 	<ol style="list-style-type: none"> 1. Change motor rotation by reversing motor 2. Repair or replace lowering valve 3. Tighten all suction line fittings 4. Replace suction tube 5. Top-off tank
Motor runs, raises lift, but not vehicle	<ol style="list-style-type: none"> 1. Motor is running on low voltage 2. Debris in lowering valve 3. Improper relief valve adjustment 4. Overloading of lift 	<ol style="list-style-type: none"> 1. Supply correct voltage to motor 2. Clean lowering valve 3. Replace relief valve cartridge 4. Check vehicle weight or balance load properly
Lift settles down slowly	<ol style="list-style-type: none"> 1. Debris in check valve 2. Debris in lowering valve 3. External oil leaks 	<ol style="list-style-type: none"> 1. Clean check valve 2. Clean lowering valve 3. Check for and repair any leaks
Anchor bolts wont stay tight or are pulling out of floor	<ol style="list-style-type: none"> 1. Cement thickness/strength insufficient 2. Holes are too big for bolts 	<ol style="list-style-type: none"> 1. Remove bad cement; pour new pad for lift per specs in manual 2. Relocate lift using the proper size drill bit, or pour anchoring cement into holes to secure bolts.
Cylinder whines or chatters	<ol style="list-style-type: none"> 1. Dry or tight seal 	<ol style="list-style-type: none"> 1. Remove cylinder vent and spray Dura-lube or Teflon spray lube

		into cylinder
Oil squirts out of cylinder well	1. Bad seal	1. Replace seal or cylinder
	2.	2.

Rub Block Shimming.txt

Procedure for Shimming Two Post Carriages

1. Separate your lift columns, lay them on their backs, move carriage from side to side and front to back to determine if they are loose or if the shims have come out.

(Sometimes this occurs in shipping)

2. If shims are needed, you then remove the cylinder and disconnect the chain.

3. Top Plates will need to be removed so you can slide the carriage out the end only exposing the carriage feet or rub block holders. There are two on each side with nylon blocks (approximately 1"x1"x3") the shims provided for you are in 1/8" and 3/8" thick these will need to be placed between the block and the block holder to fit snug in the column.

4. Replace the carriage in the column.

5. Replace top plates, for the floor model or apply the uprights, for the overhead model.

6. Replace the chain.

7. Place the cylinder back in position.

8. Release the locks and pull the carriage down to the base plate.

9. Stand each column up and proceed with your installation.



Eagle Automotive Lift Warranty

Eagle Equipment warrants to the original retail purchaser of an Eagle Automotive Lift that it will replace without charge any part found under normal use, in the United States or Canada, to be defective in materials or workmanship, **for a period of one (1) year from date of purchase.** Warranty covers parts only; purchaser is responsible for any and all labor requirements.

Exclusions

This warranty will not apply to any machine:

1. Which has not been operated or maintained according to specifications
2. Which has been abused, misused altered or improperly maintained
3. Which has been improperly installed or assembled

Other limitations

This warranty does not cover:

1. Parts needed for normal maintenance.
2. Wear parts, which include but are not limited to, cables, hoses, slider blocks, chains and rubber pads.
3. On-site labor.

Eagle Equipment reserves the right to make improvements and/or design changes to its equipment without any obligation to previously sold, assembled or fabricated equipment.

There is no other express warranty on the Eagle Automotive Lift equipment and this warranty is exclusive of and in lieu of all other warranties, expressed or implied, including all warranties of merchantability and fitness for a particular purpose.

To the fullest extent allowed by law, Eagle Equipment shall not be liable for loss of use, inconvenience, lost time, commercial loss or other incidental or consequential damages

Some States do not allow exclusion or limitation of consequential damages or how long an implied warranty lasts, so that the above limitations and exclusions may not apply. This warranty gives you specific legal rights and you may have other rights, which may vary from State to State.