

Fax

To: _____ From: _____
Fax: _____ Pages: 1
Phone: _____ Date: _____
Re: CHAIN ROLLER DIMENSIONS CC: _____

Urgent For Review Please Comment Please Reply Please Recycle

● Comments: Fill out information as listed below; and **FAX BACK TO:** 1-800-590-9814.

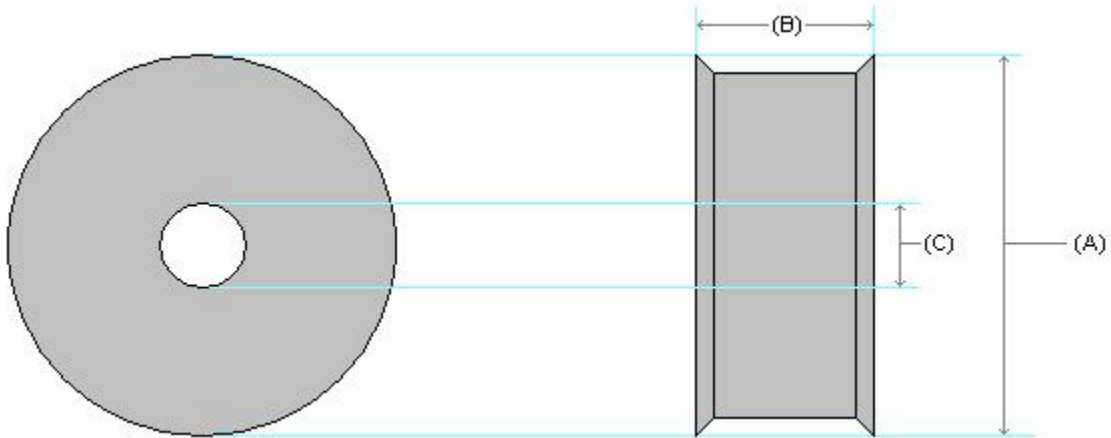

<u>A</u>	Outside Diameter (OD)	_____
<u>B</u>	Width	_____
<u>C</u>	Center Hole Diameter (ID)	_____

THANK YOU,

BILL DALIEGE
EAGLE EQUIPMENT